

This document downloaded from
vulcanhammer.net

since 1997,
your source for engineering information
for the deep foundation and marine
construction industries, and the historical
site for Vulcan Iron Works Inc.

Use subject to the “fine print” to the
right.

Don't forget to visit our companion site <http://www.vulcanhammer.org>

All of the information, data and computer software ("information") presented on this web site is for general information only. While every effort will be made to insure its accuracy, this information should not be used or relied on for any specific application without independent, competent professional examination and verification of its accuracy, suitability and applicability by a licensed professional. Anyone making use of this information does so at his or her own risk and assumes any and all liability resulting from such use. The entire risk as to quality or usability of the information contained within is with the reader. In no event will this web page or webmaster be held liable, nor does this web page or its webmaster provide insurance against liability, for any damages including lost profits, lost savings or any other incidental or consequential damages arising from the use or inability to use the information contained within.

This site is not an official site of Prentice-Hall, the University of Tennessee at Chattanooga, Vulcan Foundation Equipment or Vulcan Iron Works Inc. (Tennessee Corporation). All references to sources of equipment, parts, service or repairs do not constitute an endorsement.

OFFSHORE SOIL MECHANICS

Arnold Verruijt

Delft University of Technology

1994, 2000, 2005

PREFACE

This book was written as class notes for the course on "Offshore Soil Mechanics" of the Department of Civil Engineering of the Delft University of Technology, as given until 2002.

In the latest version, which is published on the internet, the format of the pages has been changed to the landscape shape, some figures have been improved by adding color, and multi-line formulas have been reduced to a single line, profiting from the wider page format. Also two chapters (on consolidation and waves in piles) have been copied from the Soil Dynamics book. Some additional material may be included later.

For many problems elementary computer programs are given, in Turbo Pascal. These programs may be used, copied and distributed without restriction. No responsibility for any loss or damage resulting from use of these programs is accepted, however. Some more advanced programs can be downloaded from the author's website (<http://geo.verruijt.net>).

The notes have been prepared using the \LaTeX version (Lamport, 1986) of the program \TeX (Knuth, 1986).

Delft, January 1994, August 2000; Zoetermeer, April 2005

Arnold Verruijt

CONTENTS

1	Soil Properties	4
2	Theory of Consolidation	10
3	Sea Bed Response to Cyclic Loads	31
4	Cutting Forces in Sand	44
5	Beams on Elastic Foundation	54
6	Axially Loaded Piles	68
7	Development of Pile Plug	99
8	Laterally Loaded Piles	115
9	Pile in Layered Elastic Material	145
10	Waves in Piles	164
11	Gravity Foundations	191
	References	200
	Index	202

Chapter 1

SOIL PROPERTIES

In soil mechanics the equilibrium and movement of soil bodies is studied, where soil is understood to be the weathered natural material in the upper layers (say the upper 20 to 100 m) of the earth's crust. This material may be gravel, sand, clay, peat, or some other rather soft and loose granular medium. The nature of these materials is quite different from artificial man-made materials such as steel, concrete, etc. These materials usually are much more consistent than soils, and exhibit relatively simple, linear, mechanical behaviour, at least if the deformations are not too large.

The mechanical properties of soils are usually strongly non-linear, with the material exhibiting irreversible plastic deformations when loaded and unloaded, even at low stress levels, and often showing anisotropic behaviour, creep and such typical effects as dilatancy (a volume change during shear). This mechanical behaviour of soil is also difficult to predict, because the structure of the soil may be highly inhomogeneous, because of its geological history, and it is often not possible to determine the detailed behaviour of the soil by tests in the laboratory or in situ. The behaviour of soils may be further complicated by the presence of water in the pores. This relatively stiff fluid in the pores may prevent or retard volume deformations.

For all these reasons the characterization of the mechanical behaviour of soils is often done in a schematic way only, and its form is adapted to the particular type of problem under consideration. Thus for a problem of long term settlements of an embankment the relevant soil properties are quite different from those for a problem of stability of the slopes of the same embankment. Even though these problems may seem to be closely related, the methods of analysis involve different concepts, and different parameters. In the case of stability of slopes the strength of the soil layers is the dominating effect, whereas the settlement of an embankment is mainly governed by the deformation properties of the soil, including creep.

Thus in soil mechanics the range of applicability of a certain parameter is often restricted to a limited class of problems. Many properties can not be used outside their intended field of application. Nevertheless, various properties may all derive from such common basic phenomena as interparticle friction, or the structure of a granular medium, so that there may well exist good correlations between certain properties. In this chapter some of these properties are reviewed, and some correlations are discussed. It should be noted that in engineering practice nothing can beat the results of experimental determination of the soil parameters in situ, or in the laboratory. A correlation may at best give a first estimate of the order of magnitude of a parameter.

1.1 Stiffness

In many problems of soil-structure interaction the soil is modeled by a subgrade modulus,

$$w = \frac{p}{c}, \quad (1.1)$$

where w is the settlement of a foundation element, p is the pressure upon it, and c is the subgrade modulus. The soil is modeled by a linear

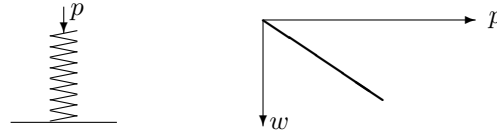

Figure 1.1: Linear spring.

spring in this case. One of the main reasons behind the use of this relation may be the simplicity of a linear relationship for analytical or numerical calculations. It is, of course, a very simplistic way of modeling soil behaviour, and it should be borne in mind that in reality soils exhibit various forms of non-linear and irreversible behaviour. In some cases it may be justified, however, to use a linear spring model, as a first approximation.

The flexibility of a plate foundation may be described by considering the soil as a linear elastic continuum, with modulus of elasticity E , and

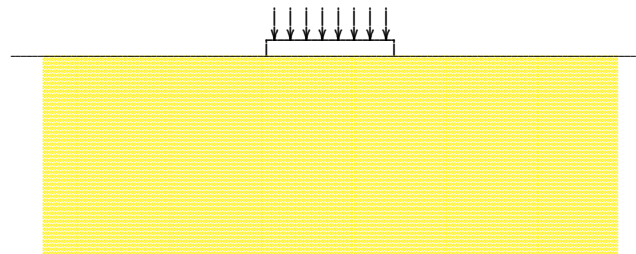

Figure 1.2: Foundation on elastic soil.

Poisson's ration ν . For a rigid circular plate the following relation between pressure and settlement may be derived, on the basis of Boussinesq's

elementary solution for a point load on an elastic half plane (Timoshenko & Goodier, 1951),

$$w = \frac{\pi(1 - \nu^2) p D}{4E}, \quad (1.2)$$

where D is the diameter of the plate. A linear relationship between the load p and the displacement w is obtained, which is of course a consequence of the assumption that the soil behaves as a linear elastic material.

It is interesting to note that a similar relation can be obtained by starting from the assumption that in the soil the stresses are distributed homogeneously over an area of gradually increasing magnitude, over an angle of say 45° with the vertical direction, see figure 1.3. This means

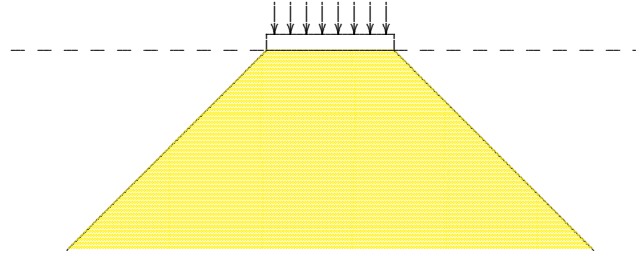

Figure 1.3: Foundation on elastic soil, approximation.

that at a depth z below the surface the area carrying the load is

$$A = \frac{1}{4}\pi(D + 2z)^2. \quad (1.3)$$

The vertical normal stress at that depth is the total force $F = \frac{1}{4}\pi D^2 p$, divided by the area A ,

$$\sigma_v = \frac{p}{(1 + 2z/D)^2}. \quad (1.4)$$

If the medium is assumed to be elastic, the strain at this depth is

$$\varepsilon_v = \frac{p}{E(1 + 2z/D)^2}. \quad (1.5)$$

Because $\varepsilon_v = dw/dz$, where w is the vertical displacement, one now obtains, after integration from $z = 0$ to $z = \infty$,

$$w = \frac{p D}{2E}. \quad (1.6)$$

Comparison of eq. (1.6) with eq. (1.2) shows that these two formulas are of the same nature. The only difference is the magnitude of the numerical coefficient. In general one may write

$$w = \frac{pD}{\alpha E}, \quad (1.7)$$

where magnitude of the coefficient α is between 1 and 2.

Comparison of eq. (1.7) with eq. (1.1) shows that the elastic subgrade model is in agreement with the elastic continuum model if

$$c = \frac{\alpha E}{D}. \quad (1.8)$$

It appears that a larger plate has a smaller average stiffness. This can be understood intuitively by noting that the soil surrounding the area of a plate is partly being taken down by the plate, so that only a small amount of additional stress is needed to displace a larger plate.

The modulus of elasticity of a soil may be correlated with the compressibility constant C in Terzaghi's logarithmic formula

$$\varepsilon = \frac{1}{C} \log\left(\frac{\sigma}{\sigma_o}\right), \quad (1.9)$$

where σ_o is the initial stress, and σ is the actual stress, $\sigma = \sigma_o + \Delta\sigma$. If the stress increment $\Delta\sigma$ is small one may write,

$$\varepsilon = \frac{1}{C} \log\left(1 + \frac{\Delta\sigma}{\sigma_o}\right) \approx \frac{\Delta\sigma}{C\sigma_o}. \quad (1.10)$$

If this is compared with the elastic relation $\varepsilon = \Delta\sigma/E$ it follows that

$$E = C\sigma_o. \quad (1.11)$$

This means that the stiffness of the soil increases linearly with the stress level, or with the depth below the soil surface. Such an increase in stiffness is indeed often observed in engineering practice, although the increase is often not so strong as the linear relation (1.11) suggests. The relation can be used to estimate the modulus of elasticity of a soil, if the compressibility C and the stress level σ_o are known. Common values are $C = 100$ to $C = 500$ for sand, and values in the range from $C = 20$ to $C = 100$ for clay. The precise value for a certain soil can easily be determined in the laboratory in an unconfined compression test (oedometer test), at least in principle. It must be noted that the values given above apply to virgin loading of a soil, under relatively large deformations. When unloading a soil, or reloading it below the maximum stress ever reached before, the soil is much stiffer, say by a factor 10. Thus in the case of very small deformations a soil may be much stiffer than in the case of large deformations beyond the pre-consolidation stress level.

It is sometimes considered too complicated to take a sample, determine its compressibility in the laboratory, and then use this value to calculate the appropriate stiffness for the structure. This procedure requires a very careful handling of the soil sample, during sampling,

transport, and subsequent laboratory testing, with a large probability of disturbance of the sample. Therefore this procedure may be replaced by a direct determination of the soil stiffness in situ, for instance by a plate loading test. Errors due to taking the sample in the field, and those due to transporting and handling the sample are avoided in this way. The only problem then remaining is a problem of scaling the results up to the dimensions of the actual structure. For offshore conditions special equipment has been developed to perform plate loading tests under water.

1.2 Strength

Soils usually cannot transfer stresses beyond a certain limit. This is called the strength of the soil. The shear strength of soils is usually expressed by Coulomb's relation between the maximum shear stress τ_{max} and the effective normal stress σ' ,

$$\tau_{max} = c + \sigma' \tan \phi, \quad (1.12)$$

where c is the cohesion and ϕ is the friction angle. For sands the cohesion c is usually negligible, so that the friction angle ϕ is the only strength parameter. For clays it is often most relevant to consider the strength in undrained conditions, during which the effective stress σ' remains constant. The undrained shear strength is usually denoted by s_u , and it is often considered irrelevant to what degree this is to be attributed to cohesion or friction. The shear strength parameters can be determined in the laboratory, for instance by triaxial testing.

A simple and useful in situ test is the cone penetration test (CPT), in which a cone is pushed into the ground using hydraulic pressure equipment, while recording the stress at the tip of the cone, and often also the friction along the lower part of the shaft. The test is used in The Netherlands as a model test for a pile foundation, and the results are used directly to determine the bearing capacity of end bearing piles, using simple scale rules.

The CPT can also be used to estimate the strength of a soil, however, by using certain correlations. For a penetration test in sand, for instance, the bearing capacity of the cone q_c is, according to Brinch Hansen's formula,

$$q_c = s_q N_q \sigma'_v = s_q N_q \gamma' z, \quad (1.13)$$

where s_q is a shape factor, for which one may use $s_q = 1 + \sin \phi$, γ' is the effective weight of the overburden, z is the depth, and N_q is a dimensionless constant for which theoretical analysis has given the value

$$N_q = \frac{1 + \sin \phi}{1 - \sin \phi} \exp(\pi \tan \phi). \quad (1.14)$$

For various types of sand the cone resistance q_c , at a depth of 10 m and 20 m, respectively, is predicted in table 1.1, assuming that $\gamma' = 10 \text{ kN/m}^3$. These are values that are indeed often observed for sand layers at 10 m or 20 m depth. They may also be used inversely: if a certain cone resistance is observed, it is indicative for a certain type of material.

Type of soil	ϕ	N_q	$q_c (z = 10 \text{ m})$	$q_c (z = 20 \text{ m})$
Loose sand	30°	18.4	2.8 MPa	5.5 MPa
Medium dense sand	35°	33.3	5.2 MPa	10.5 MPa
Very dense sand	40°	64.2	10.5 MPa	21.1 MPa

Table 1.1: Cone resistance in sand.

For a cone penetration test in clay soil the Brinch Hansen formula can be used to correlate the CPT result to the undrained shear strength. The general Brinch Hansen formula is

$$q_c = s_c N_c c + s_q N_q \sigma'_v. \quad (1.15)$$

Because the test is performed very quickly, the soil behaviour can be considered to be undrained, and one may take $\phi = 0$. The values for the coefficients can then be taken as $N_c = 5.14$, $N_q = 1$, $s_c = 1.3$, $s_q = 1$. Eq. (1.15) now reduces to

$$q_c = 6.7 s_u + \sigma'_v, \quad (1.16)$$

where the cohesion c has been interpreted as the undrained shear strength s_u .

The undrained shear strength of normally consolidated clays depends upon the vertical stress σ'_v . A relationship that is often used is the correlation proposed by Ladd,

$$s_u = 0.22 \sigma'_v, \quad (1.17)$$

Substitution of this result into (1.16) gives

$$q_c \approx 11 s_u. \quad (1.18)$$

For a soft clay, with $s_u = 20 \text{ kPa}$, the order of magnitude of the cone resistance would be $220 \text{ kPa} \approx 0.2 \text{ MPa}$. Such values are indeed often observed. Again they may also be used to estimate the undrained shear strength from CPT data.

Both Coulomb's formula for sand and the correlation (1.17) for clay express that the soil strength is proportional to the stress level. As it was seen earlier that the soil stiffness is also proportional to this stress level, see (1.11), it follows that the strength and the stiffness of soils are correlated. As a first approximation one might say that the soil stiffness E is several hundred times the shear strength.

It should be emphasized that all the relations given in this chapter are of a qualitative and approximative character. They should be used with great care, and only to estimate the possible range of values of certain parameters. For realistic quantitative predictions of soil behaviour the local soil should be investigated, in situ or in the laboratory on the basis of samples.

THEORY OF CONSOLIDATION

2.1 Introduction

Soft soils such as sand and clay consist of small particles, and often the pore space between the particles is filled with water. In mechanics this is denoted as a saturated (or at least partially saturated) porous medium. The deformation of fully saturated porous media depends upon the stiffness of the porous material, but also upon the behaviour of the fluid in the pores. If the permeability of the material is small, the deformations may be considerably hindered, or at least retarded, by the pore fluid. The simultaneous deformation of the porous material and flow of pore fluid is the subject of the theory of consolidation. In this chapter the basic equations of this theory are derived, for the case of a linear material. The theory was developed originally by Terzaghi (1925) for the one-dimensional case, and extended to three dimensions by Biot (1941), and it has been studied extensively since. A simplified version of the theory, in which the soil deformation is assumed to be strictly vertical, is also presented in this chapter. The analytical solutions for two simple examples are given.

2.2 Conservation of mass

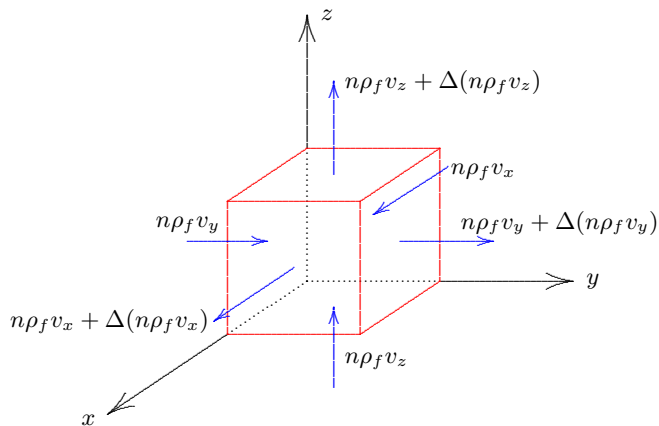

Figure 2.1: Conservation of mass of the fluid.

Consider a porous material, consisting of a solid matrix or an assembly of particles, with a continuous pore space. The pore space is filled with a fluid, usually water, but possibly some other fluid, or a mixture of fluids. The average velocity of the fluid is denoted by \mathbf{v} and the velocity of the solids is denoted by \mathbf{w} . The densities are denoted by ρ_f and ρ_s , respectively, and the porosity by n .

The equations of conservation of mass of the solids and the fluid can be established by considering the flow into and out of an elementary volume, fixed in space, see figure 2.1. The mass of fluid in an elementary volume V is $n\rho_f V$. The increment of this mass per unit time is determined by the net inward flux across the surfaces of the element. In y -direction the flow through the left and the right faces of the element shown in figure 2.1 (both having an area $\Delta x \Delta z$), results in a net outward flux of magnitude

$$\Delta(n\rho_f v_y)\Delta x \Delta z = \frac{\Delta(n\rho_f v_y)}{\Delta y} V,$$

where the volume V has been written as $\Delta x \Delta y \Delta z$. This leads to the following mass balance equation

$$\frac{\partial(n\rho_f)}{\partial t} + \frac{\partial(n\rho_f v_x)}{\partial x} + \frac{\partial(n\rho_f v_y)}{\partial y} + \frac{\partial(n\rho_f v_z)}{\partial z} = 0. \quad (2.1)$$

Using vector notation this can also be written as

$$\frac{\partial(n\rho_f)}{\partial t} + \nabla \cdot (n\rho_f \mathbf{v}) = 0. \quad (2.2)$$

Similarly, the balance equation for the solid material can be written as

$$\frac{\partial[(1-n)\rho_s]}{\partial t} + \nabla \cdot [(1-n)\rho_s \mathbf{w}] = 0, \quad (2.3)$$

It is assumed that all deformations of the solid matrix are caused by a rearrangement of the particles. The particles themselves are assumed to be incompressible. This means that the density ρ_s of the solids is constant. In that case eq. (2.3) reduces to

$$-\frac{\partial n}{\partial t} + \nabla \cdot [(1-n)\mathbf{w}] = 0, \quad (2.4)$$

Although the pore fluid is often also practically incompressible this will not be assumed, in order to have the possibility of studying the effect of a compressible fluid. The density of the pore fluid is assumed to depend upon the fluid pressure by the following equation of state

$$\rho_f = \rho_o \exp[\beta(p - p_o)], \quad (2.5)$$

where β is the compressibility of the fluid, p is the pressure, and ρ_o and p_o are reference quantities. For pure water the compressibility is about $0.5 \times 10^{-9} \text{ m}^2/\text{kN}$. For a fluid containing small amounts of a gas the compressibility may be considerably larger, however. It follows from eq. (2.5) that

$$d\rho_f = \beta\rho_f dp. \quad (2.6)$$

The equation of conservation of mass of the fluid, eq. (2.2) can now be written as follows, when second order non-linear terms are disregarded,

$$\frac{\partial n}{\partial t} + n\beta \frac{\partial p}{\partial t} + \nabla \cdot (n\mathbf{v}) = 0. \quad (2.7)$$

The time derivative of the porosity n can easily be eliminated from eqs. (2.4) and (2.7) by adding these two equations. This gives

$$n\beta \frac{\partial p}{\partial t} + \nabla \cdot [n(\mathbf{v} - \mathbf{w})] + \nabla \cdot \mathbf{w} = 0. \quad (2.8)$$

The quantity $n(\mathbf{v} - \mathbf{w})$ is the porosity multiplied by the relative velocity of the fluid with respect to the solids. This is precisely what is intended by the *specific discharge*, which is the quantity that appears in Darcy's law for fluid motion. This quantity will be denoted by \mathbf{q} ,

$$\mathbf{q} = n(\mathbf{v} - \mathbf{w}). \quad (2.9)$$

If the displacement vector of the solids is denoted by \mathbf{u} , the term $\nabla \cdot \mathbf{w}$ can also be written as $\partial \varepsilon_{vol} / \partial t$, where ε_{vol} is the volume strain,

$$\varepsilon_{vol} = \nabla \cdot \mathbf{u}. \quad (2.10)$$

Equation (2.8) can now be written as

$$-\frac{\partial \varepsilon_{vol}}{\partial t} = n\beta \frac{\partial p}{\partial t} + \nabla \cdot \mathbf{q}. \quad (2.11)$$

This is the *storage equation*. It is one of the most important equations from the theory of consolidation. It admits a simple heuristic interpretation: the compression of the soil consists of the compression of the pore fluid plus the amount of fluid expelled from an element by flow. The equation actually expresses conservation of mass of fluids and solids, together with some notions about the compressibilities.

It should be noted that in the formal derivation of eq. (2.11) a number of assumptions have been made, but these are all relatively realistic. Thus, it has been assumed that the solid particles are incompressible, and that the fluid is linearly compressible, and some second order terms, consisting of the products of small quantities, have been disregarded. The storage equation (2.11) can be considered as a reasonably accurate description of physical reality.

It may also be noted that eq. (2.4) can also be written as

$$\frac{\partial n}{\partial t} = (1 - n) \frac{\partial \varepsilon_{vol}}{\partial t}, \quad (2.12)$$

if a small error in a second order term is neglected. This equation enables to express the volume change in a change of porosity.

2.3 Darcy's law

In 1857 Darcy found, from a series of experiments, that the specific discharge of a fluid in a porous material is proportional to the head loss. In terms of the quantities used in this chapter Darcy's law can be written as

$$\mathbf{q} = -\frac{\kappa}{\mu} (\nabla p - \rho_f \mathbf{g}), \quad (2.13)$$

where κ is the (intrinsic) permeability of the porous material, μ is the viscosity of the fluid, and \mathbf{g} is the gravity vector. The permeability depends upon the size of the pores. As a first approximation one may consider that the permeability κ is proportional to the square of the particle size.

If the coordinate system is such that the z -axis is pointing in upward vertical direction the components of the gravity vector are $g_x = 0$, $g_y = 0$, $g_z = -g$, and then Darcy's law may also be written as

$$\begin{aligned} q_x &= -\frac{\kappa}{\mu} \frac{\partial p}{\partial x}, \\ q_y &= -\frac{\kappa}{\mu} \frac{\partial p}{\partial y}, \\ q_z &= -\frac{\kappa}{\mu} \left(\frac{\partial p}{\partial z} + \rho_f g \right). \end{aligned} \quad (2.14)$$

The product $\rho_f g$ may also be written as γ_w , the volumetric weight of the fluid.

In soil mechanics practice the coefficient in Darcy's law is often expressed in terms of the hydraulic conductivity k rather than the permeability κ . This hydraulic conductivity is defined as

$$k = \frac{\kappa \rho_f g}{\mu}. \quad (2.15)$$

Thus Darcy's law can also be written as

$$\begin{aligned} q_x &= -\frac{k}{\gamma_w} \frac{\partial p}{\partial x}, \\ q_y &= -\frac{k}{\gamma_w} \frac{\partial p}{\partial y}, \\ q_z &= -\frac{k}{\gamma_w} \left(\frac{\partial p}{\partial z} + \gamma_w \right). \end{aligned} \quad (2.16)$$

From the above equations it follows that

$$\nabla \cdot \mathbf{q} = \frac{\partial q_x}{\partial x} + \frac{\partial q_y}{\partial y} + \frac{\partial q_z}{\partial z} = -\nabla \cdot \left(\frac{k}{\gamma_w} \nabla p \right), \quad (2.17)$$

if again a small second order term (involving the spatial derivative of the hydraulic conductivity) is disregarded.

Substitution of (2.17) into (2.11) gives

$$-\frac{\partial \varepsilon_{vol}}{\partial t} = n\beta \frac{\partial p}{\partial t} - \nabla \cdot \left(\frac{k}{\gamma_w} \nabla p \right). \quad (2.18)$$

Compared to eq. (2.11) the only additional assumption is the validity of Darcy's law. As Darcy's law usually gives a good description of flow in a porous medium, equation (2.18) can be considered as reasonably accurate.

2.4 One-dimensional consolidation

In order to complete the system of equations the deformation of the solid material must be considered. In general this involves three types of equations: equilibrium, compatibility, and a stress-strain-relation. This is rather unfortunate, as the first basic equation, eq. (2.18) is rather simple, and involves only two basic variables: the pore pressure p and the volume strain ε_{vol} . It would be mathematically most convenient if a second equation relating the volume strain to the pore pressure could be found. Unfortunately, this can only be achieved for a class of simple problems, for instance those in which the deformation is in vertical direction only. This case of one-dimensional consolidation is considered in this section.

Let it be assumed that there are no horizontal deformations,

$$\varepsilon_{xx} = \varepsilon_{yy} = 0. \quad (2.19)$$

A volume change can now occur only by vertical deformation,

$$\varepsilon_{vol} = \varepsilon_{zz}. \quad (2.20)$$

It can be expected that the vertical strain ε_{zz} is mainly determined by the vertical effective stress. If it is assumed that this relation is linear, one may write

$$\varepsilon_{zz} = -\alpha\sigma'_{zz}, \quad (2.21)$$

where α is the compressibility of the soil. The minus sign has been introduced to account for the inconsistent system of sign conventions: strains positive for extension and stresses positive for compression.

According to Terzaghi's principle of effective stress, the vertical effective stress is the difference of the total stress and the pore pressure,

$$\sigma'_{zz} = \sigma_{zz} - p. \quad (2.22)$$

It now follows from eqs. (2.20) - (2.22) that

$$\frac{\partial \varepsilon_{vol}}{\partial t} = -\alpha \left(\frac{\partial \sigma_{zz}}{\partial t} - \frac{\partial p}{\partial t} \right). \quad (2.23)$$

This is the simple second relation between ε_{vol} and p that was being sought. Substitution into eq. (2.18) finally gives

$$(\alpha + n\beta) \frac{\partial p}{\partial t} = \alpha \frac{\partial \sigma_{zz}}{\partial t} + \nabla \cdot \left(\frac{k}{\gamma_w} \nabla p \right). \quad (2.24)$$

This is a relatively simple differential equation for the pore pressure p , of the diffusion type. The first term in the right hand side is assumed to be given from the loading conditions.

It should be noted that in this section a number of very serious approximations has been introduced. This means that the final equation (2.24) is much less accurate than the continuity equation (2.18). The horizontal deformations have been neglected, the influence of the horizontal stresses upon the vertical deformation has been neglected, and, perhaps worst of all, the stress-strain-relation has been assumed to be linear. Nevertheless, in soil mechanics practice it is often argued that the complicated soil behaviour can never fully be accounted for, and at least the most important effects, vertical equilibrium and vertical deformation, have been taken into consideration in this simplified theory. As the pore pressures and the vertical deformations usually are also the most interesting quantities to calculate, this simplified theory may often be a very valuable first approximation.

For the solution of a particular problem the boundary conditions should also be taken into account. In many cases this leads to a complicated mathematical problem. Analytical solutions exist only for simple geometries, such as the consolidation of a horizontal layer with a homogeneous load (this is Terzaghi's classical one-dimensional problem), or radial consolidation. As an example the solution of Terzaghi's problem of one-dimensional consolidation will be given here.

2.4.1 Terzaghi's problem

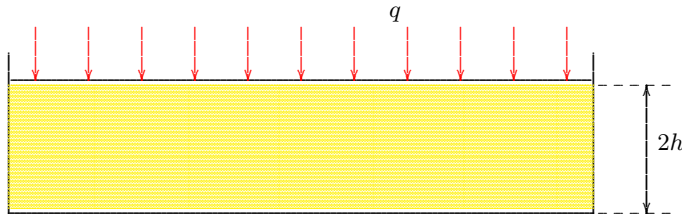

Figure 2.2: Terzaghi's problem.

Here it has been assumed that the ratio k/γ_w is a constant. The first term in the right hand side represents the loading rate, which is very large (approaching infinity) at the moment of loading, and is zero afterwards. In order to study the behaviour at the time of loading one may integrate eq. (2.25) over a short time interval Δt and then assuming that $\Delta t \rightarrow 0$. This gives

$$\Delta p = \frac{\alpha}{\alpha + n\beta} \Delta \sigma_{zz}. \quad (2.26)$$

Thus, if at time $t = 0$ the vertical stress suddenly increases from 0 to q , the pore water pressure will increase to a value p_0 such that

$$p_0 = \frac{\alpha}{\alpha + n\beta} q. \quad (2.27)$$

The problem first solved by Terzaghi (1925) is that of a layer of thickness $2h$, which is loaded at time $t = 0$ by a load of constant magnitude q . The upper and lower boundaries of the soil layer are fully drained, so that along these boundaries the pore pressure p remains zero.

The differential equation for this case is the fully one-dimensional form of eq. (2.24),

$$(\alpha + n\beta) \frac{\partial p}{\partial t} = \alpha \frac{\partial \sigma_{zz}}{\partial t} + \frac{k}{\gamma_w} \frac{\partial^2 p}{\partial z^2}. \quad (2.25)$$

When the fluid is practically incompressible ($\beta \rightarrow 0$) the coefficient in the right hand side approaches 1, indicating that the initial pore pressure equals the external load. Thus initially the water carries all the load, due to the fact that the water is incompressible and no water has yet been drained out of the soil, so that there can not yet have been any deformation.

After the load has been applied the term $\partial\sigma_{zz}/\partial t$ is zero, because the load is constant in time. Eq. (2.25) then reduces to

$$\frac{\partial p}{\partial t} = c_v \frac{\partial^2 p}{\partial z^2}, \quad (2.28)$$

where c_v is the *consolidation coefficient*,

$$c_v = \frac{k}{(\alpha + n\beta)\gamma_w}. \quad (2.29)$$

The initial condition is

$$t = 0 : \quad p = p_0 = \frac{\alpha}{\alpha + n\beta} q. \quad (2.30)$$

and the boundary conditions are

$$z = 0 : \quad p = 0, \quad (2.31)$$

$$z = 2h : \quad p = 0. \quad (2.32)$$

The mathematical problem to be solved is completely determined by the equations (2.28) - (2.32).

Solution

The solution of the problem can be obtained by using the mathematical tools supplied by the theory of partial differential equations, for instance the method of separation of variables (see e.g. Wylie, 1960), or, even more conveniently, by the Laplace transform method (see e.g. Churchill, 1972, or Appendix A). The Laplace transform of the pore pressure is defined as

$$\bar{p} = \int_0^\infty p \exp(-st) dt, \quad (2.33)$$

where s is a positive parameter. The basic principle of the Laplace transform method is to multiply the differential equation, in this case eq. (2.28), by the factor $\exp(-st)$, and then integrating the result from $t = 0$ to $t = \infty$. This gives, using partial integration to evaluate the integral over the time derivative, and also using the initial condition (2.30),

$$s\bar{p} - p_0 = c_v \frac{d^2\bar{p}}{dz^2}. \quad (2.34)$$

The partial differential equation has now been reduced to an ordinary differential equation. The general solution of this equation is

$$\bar{p} = \frac{p_0}{s} + A \exp(z\sqrt{s/c_v}) + B \exp(-z\sqrt{s/c_v}). \quad (2.35)$$

Here A and B are integration constants, that may depend upon the Laplace transform parameter s . They can be determined using the boundary conditions (2.31) and (2.32). The final result for the transformed pore pressure is

$$\frac{\bar{p}}{p_0} = \frac{1}{s} - \frac{\cosh[(h-z)\sqrt{s/c_v}]}{s \cosh[h\sqrt{s/c_v}]}. \quad (2.36)$$

The inverse transform of this expression can be obtained by the complex inversion integral (Churchill, 1972), or in a more simple, although less rigorous way, by application of Heaviside's expansion theorem (Appendix A). This theorem states that the inverse transform of a function of the form $f(s) = P(s)/Q(s)$, where the order of the denominator $Q(s)$ should be higher than that of the numerator $P(s)$, consists of a series of terms, one for each of the zeros of the denominator $Q(s)$. Each of these terms gives a contribution of the form

$$\frac{p}{p_0} = \frac{P(s_j)}{Q'(s_j)} \exp(-s_j t). \quad (2.37)$$

In this case the denominator is the function

$$Q(s) = s \cosh[h\sqrt{s/c_v}]. \quad (2.38)$$

The zeros of this function are $s = 0$, and the zeros of the function $\cosh[. . .]$, which are

$$s = s_j = -(2j-1)^2 \frac{\pi^2 c_v}{4h^2}, \quad j = 1, 2, \dots$$

In that case $h\sqrt{s/c_v} = i(2j-1)\pi/2$, where i is the imaginary unit, $i = \sqrt{-1}$. For these values the function $\cosh[. . .]$ is indeed zero.

It can easily be seen that the values of the numerator $P(s)$ and the derivative of the denominator $Q(s)$ for $s = 0$ are both 1, so that the contribution of this zero cancels the contribution of the first term in the right side of eq. (2.36). The value of the numerator $P(s)$ for $s = s_j$ is

$$P(s_j) = \cos\left[(2j-1)\frac{\pi}{2}\left(\frac{h-z}{h}\right)\right]. \quad (2.39)$$

and the value of the derivative of the denominator for $s = s_j$ is

$$Q'(s_j) = \frac{h\sqrt{s_j/c_v}}{2} \sinh[h\sqrt{s_j/c_v}], \quad (2.40)$$

or, using that $h\sqrt{s/c_v} = i(2j - 1)\pi/2$,

$$Q'(s_j) = -\frac{\pi}{4}(2j - 1) \sin[(2j - 1)\pi/2] = -\frac{\pi}{4}(2j - 1)(-1)^{j-1}. \quad (2.41)$$

The final result now is

$$\frac{p}{p_0} = \frac{4}{\pi} \sum_{j=1}^{\infty} \left\{ \frac{(-1)^{j-1}}{2j - 1} \cos\left[(2j - 1)\frac{\pi}{2}\left(\frac{h - z}{h}\right)\right] \exp\left[-(2j - 1)^2 \frac{\pi^2}{4} \frac{c_v t_1}{h^2}\right] \right\}. \quad (2.42)$$

This is the analytical solution of the problem. It can be found in many textbooks on theoretical soil mechanics, and also in many textbooks on the theory of heat conduction, as that is governed by the same equations. Because it has been derived here by a method that is mathematically not fully applicable (Heaviside's expansion theorem, strictly speaking, applies only to a function consisting of the quotient of two polynomials), it is advisable to check whether the solution indeed satisfies all requirements. That it indeed satisfies the differential equation (2.28) can be demonstrated rather easily, because each term satisfies this equation. It can also directly be seen that it satisfies the boundary conditions (2.31) and (2.32) because for $z = 0$ and for $z = 2h$ the function $\cos(\dots)$ is zero. It is not so easy to verify that the initial condition (2.30) is also satisfied. A relatively simple method to verify this is to write a computer program that calculates values of the infinite series, and then to show that for any value of z and for very small values of t the value is indeed 1. It will be observed that this requires a very large number of terms. If t is exactly zero, it will even be found that the series does not converge.

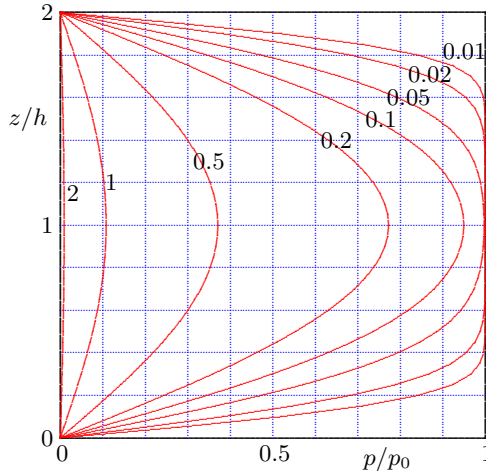

Figure 2.3: Analytical solution of Terzaghi's problem.

the boundary conditions, and the initial condition. It does not show, of course, that it is the correct solution. That can only be shown by analytical means, as presented above.

For reasonably large values of the time t the series solution will converge very rapidly, because of the factor $(2j - 1)^2$ in the argument of the exponential function. This means that for sufficiently large values of time the solution can be approximated by the first term,

$$\frac{p}{p_0} \approx \frac{4}{\pi} \cos\left[\frac{\pi}{2}\left(\frac{h - z}{h}\right)\right] \exp\left[-\frac{\pi^2}{4} \frac{c_v t}{h^2}\right]. \quad (2.43)$$

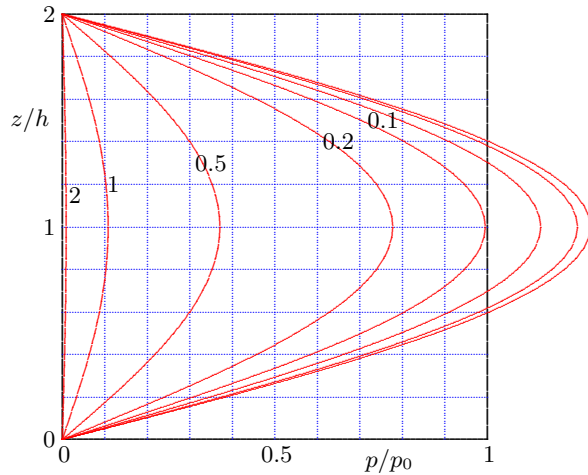

Figure 2.4: First term of solution.

This approximation is shown graphically in figure 2.4. It can be seen that for values of the dimensionless time parameter $c_v t/h^2$ larger than about 0.2, it is sufficient to use one term only. For very small values of the time parameter the approximation by one single term is of course very bad, as can also be seen from figure 2.4. Actually for $t = 0$ the first term is the first term of the Fourier expansion of the block function that describes the initial values of the pore pressure. In order to describe such a block well a very large number of terms in a Fourier expansion is needed, and the first term is a very poor approximation (Wylie, 1960).

Settlement

The progress of the settlement in time can be obtained from the solution (2.42) by noting that the strain is determined by the effective stress,

$$\varepsilon = -\alpha\sigma'_{zz} = -\alpha(\sigma_{zz} - p). \quad (2.44)$$

The settlement is the integral of this strain over the height of the sample,

$$w = -\int_0^{2h} \varepsilon dz = 2\alpha h q - \alpha \int_0^{2h} p dz. \quad (2.45)$$

The first term in the right hand side is the final settlement, which will be reached when the pore pressures have been completely dissipated. This value will be denoted by w_∞ ,

$$w_\infty = 2\alpha h q. \quad (2.46)$$

Immediately after the application of the load q the pore pressure is equal to p_0 , see eq. (2.30). This means that the immediate settlement, at the moment of loading, is

$$w_0 = 2\alpha h q \frac{n\beta}{\alpha + n\beta}. \quad (2.47)$$

If the fluid is incompressible ($\beta = 0$), the initial settlement is zero.

In order to describe the settlement as a function of time it is convenient to introduce the *degree of consolidation* U , defined as

$$U = \frac{w - w_0}{w_\infty - w_0}. \quad (2.48)$$

This quantity will vary between 0 (at the moment of loading) and 1 (after consolidation has finished). With (2.45), (2.46) and (2.47) this is found to be related to the pore pressures by

$$U = \frac{1}{2h} \int_0^{2h} \frac{p_0 - p}{p_0} dz. \quad (2.49)$$

Using the solution (2.42) for the pore pressure distribution the final expression for the degree of consolidation as a function of time is

$$U = 1 - \frac{8}{\pi^2} \sum_{j=1}^{\infty} \frac{1}{(2j-1)^2} \exp\left[-(2j-1)^2 \frac{\pi^2}{4} \frac{c_v t}{h^2}\right]. \quad (2.50)$$

For $t \rightarrow \infty$ this is indeed 0. For $t = 0$ it is 1, because then the terms in the infinite series add up to $\pi^2/8$. A graphical representation of the degree of consolidation as a function of time is shown in figure 2.5.

Theoretically speaking the consolidation phenomenon is finished if $t \rightarrow \infty$. For all practical purposes it can be considered as finished when the argument of the exponential function in the first term of the series is about 4 or 5. This will be the case when

$$\frac{c_v t}{h^2} \approx 2. \quad (2.51)$$

This is a very useful formula, because it enables to estimate the duration of the consolidation process. It also enables to evaluate the influence of the various parameters on the consolidation process. If the permeability is twice as large, consolidation will take half as long. If the drainage length is reduced by a factor

2, the duration of the consolidation process is reduced by a factor 4. This explains the usefulness of improving the drainage in order to accelerate consolidation.

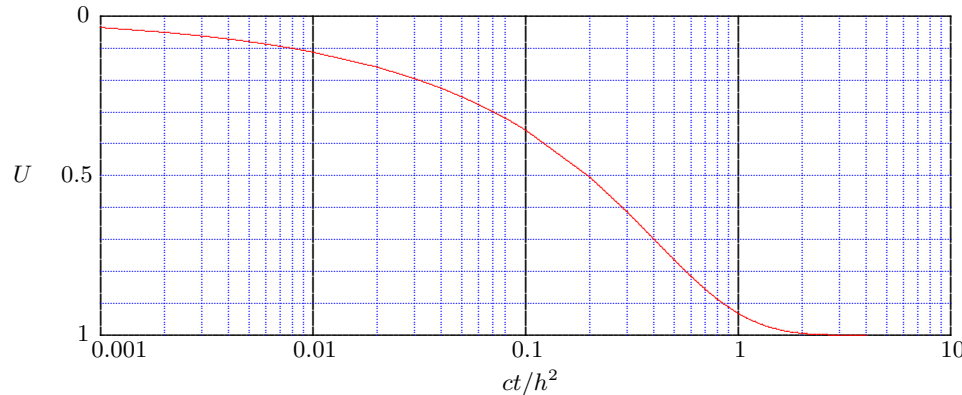

Figure 2.5: Degree of consolidation.

In engineering practice the consolidation process is sometimes accelerated by installing vertical drains. In a thick clay deposit this may be very effective, because it reduces the drainage length from the thickness of the layer to the distance of the drains. As the consolidation is proportional to the square of the drainage length, this may be extremely effective in reducing the consolidation time, and thus accelerating the subsidence due to the construction of an embankment.

2.5 Three-dimensional consolidation

The complete formulation of a fully three-dimensional problem requires a consideration of the principles of solid mechanics, including equilibrium, compatibility and the stress-strain-relations. In addition to these equations the initial conditions and the boundary conditions must be formulated. These equations are presented here, for a linear elastic material.

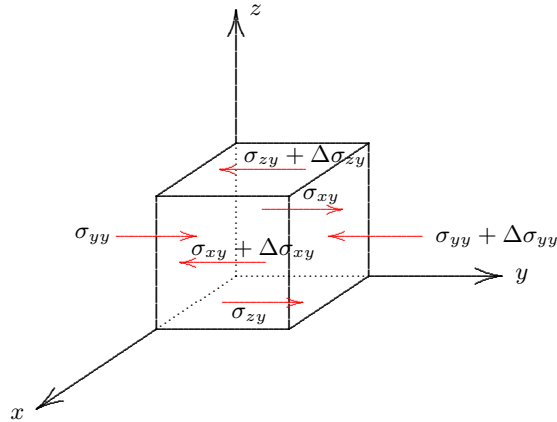

Figure 2.6: Equilibrium of element.

The equations of equilibrium can be established by considering the stresses acting upon the six faces of an elementary volume, see figure 2.6. In this figure only the six stress components in the y -direction are shown. The equilibrium equations in the three coordinate directions are

$$\begin{aligned} \frac{\partial \sigma_{xx}}{\partial x} + \frac{\partial \sigma_{yx}}{\partial y} + \frac{\partial \sigma_{zx}}{\partial z} - f_x &= 0, \\ \frac{\partial \sigma_{xy}}{\partial x} + \frac{\partial \sigma_{yy}}{\partial y} + \frac{\partial \sigma_{zy}}{\partial z} - f_y &= 0, \\ \frac{\partial \sigma_{xz}}{\partial x} + \frac{\partial \sigma_{yz}}{\partial y} + \frac{\partial \sigma_{zz}}{\partial z} - f_z &= 0, \end{aligned} \quad (2.52)$$

where f_x , f_y and f_z denote the components of a possible body force.

In addition to these equilibrium conditions there are three equations of equilibrium of moments. These can be taken into account most conveniently by noting that they result in the symmetry of the stress tensor,

$$\begin{aligned} \sigma_{xy} &= \sigma_{yx}, \\ \sigma_{yz} &= \sigma_{zy}, \\ \sigma_{zx} &= \sigma_{xz}. \end{aligned} \quad (2.53)$$

The stresses in these equations are total stresses. They are considered positive for compression, in agreement with common soil mechanics practice, but in contrast with the usual sign convention in solid mechanics.

The total stresses are related to the effective stresses and the pore pressure by the generalized form of Terzaghi principle,

$$\begin{aligned}
 \sigma_{xx} &= \sigma'_{xx} + p, & \sigma_{xy} &= \sigma'_{xy}, & \sigma_{xz} &= \sigma'_{xz}, \\
 \sigma_{yy} &= \sigma'_{yy} + p, & \sigma_{yz} &= \sigma'_{yz}, & \sigma_{yx} &= \sigma'_{yx}, \\
 \sigma_{zz} &= \sigma'_{zz} + p, & \sigma_{zx} &= \sigma'_{zx}, & \sigma_{zy} &= \sigma'_{zy}.
 \end{aligned}
 \tag{2.54}$$

The effective stresses are a measure for the concentrated forces transmitted from grain to grain in the contact points. It is normally assumed in soil mechanics that these determine the deformation of the soil. The shear stresses can of course only be transmitted by the soil skeleton.

The effective stresses are now supposed to be related to the strains by the generalized form of Hooke's law, as a first approximation. For an isotropic material these relations are

$$\begin{aligned}
 \sigma'_{xx} &= -\lambda\varepsilon_{vol} - 2\mu\varepsilon_{xx}, & \sigma'_{xy} &= -2\mu\varepsilon_{xy}, & \sigma'_{xz} &= -2\mu\varepsilon_{xz}, \\
 \sigma'_{yy} &= -\lambda\varepsilon_{vol} - 2\mu\varepsilon_{yy}, & \sigma'_{yz} &= -2\mu\varepsilon_{yz}, & \sigma'_{yx} &= -2\mu\varepsilon_{yx}, \\
 \sigma'_{zz} &= -\lambda\varepsilon_{vol} - 2\mu\varepsilon_{zz}, & \sigma'_{zx} &= -2\mu\varepsilon_{zx}, & \sigma'_{zy} &= -2\mu\varepsilon_{zy},
 \end{aligned}
 \tag{2.55}$$

where λ and μ are the elastic coefficients of the material (Lamé's constants). They are related to the compression modulus (or bulk modulus) K and the shear modulus G by the equations

$$\lambda = K - \frac{2}{3}G, \quad G = \mu.
 \tag{2.56}$$

The volume strain ε_{vol} in eqs. (2.55) is the sum of the three linear strains,

$$\varepsilon_{vol} = \varepsilon_{xx} + \varepsilon_{yy} + \varepsilon_{zz}.
 \tag{2.57}$$

The strain components are related to the displacement components by the compatibility equations

$$\begin{aligned}
 \varepsilon_{xx} &= \frac{\partial u_x}{\partial x}, & \varepsilon_{xy} &= \frac{1}{2}\left(\frac{\partial u_x}{\partial y} + \frac{\partial u_y}{\partial x}\right), & \varepsilon_{xz} &= \frac{1}{2}\left(\frac{\partial u_x}{\partial z} + \frac{\partial u_z}{\partial x}\right), \\
 \varepsilon_{yy} &= \frac{\partial u_y}{\partial y}, & \varepsilon_{yz} &= \frac{1}{2}\left(\frac{\partial u_y}{\partial z} + \frac{\partial u_z}{\partial y}\right), & \varepsilon_{yx} &= \frac{1}{2}\left(\frac{\partial u_y}{\partial x} + \frac{\partial u_x}{\partial y}\right), \\
 \varepsilon_{zz} &= \frac{\partial u_z}{\partial z}, & \varepsilon_{zx} &= \frac{1}{2}\left(\frac{\partial u_z}{\partial x} + \frac{\partial u_x}{\partial z}\right), & \varepsilon_{zy} &= \frac{1}{2}\left(\frac{\partial u_z}{\partial y} + \frac{\partial u_y}{\partial z}\right).
 \end{aligned}
 \tag{2.58}$$

This completes the system of basic field equations. The total number of unknowns is 22 (9 stresses, 9 strains, 3 displacements and the pore pressure), and the total number of equations is also 22 (6 equilibrium equations, 9 compatibility equations, 6 independent stress-strain-relations, and the storage equation).

The system of equations can be simplified considerably by eliminating the stresses and the strains, finally expressing the equilibrium equations in the displacements. For a homogeneous material (when λ and μ are constant) these equations are

$$\begin{aligned}(\lambda + \mu) \frac{\partial \varepsilon_{vol}}{\partial x} + \mu \nabla^2 u_x + f_x - \frac{\partial p}{\partial x} &= 0, \\(\lambda + \mu) \frac{\partial \varepsilon_{vol}}{\partial y} + \mu \nabla^2 u_y + f_y - \frac{\partial p}{\partial y} &= 0, \\(\lambda + \mu) \frac{\partial \varepsilon_{vol}}{\partial z} + \mu \nabla^2 u_z + f_z - \frac{\partial p}{\partial z} &= 0,\end{aligned}\tag{2.59}$$

where the volume strain ε_{vol} should now be expressed as

$$\varepsilon_{vol} = \frac{\partial u_x}{\partial x} + \frac{\partial u_y}{\partial y} + \frac{\partial u_z}{\partial z},\tag{2.60}$$

and the operator ∇^2 is defined as

$$\nabla^2 = \frac{\partial^2}{\partial x^2} + \frac{\partial^2}{\partial y^2} + \frac{\partial^2}{\partial z^2}.\tag{2.61}$$

The system of differential equations now consists of the storage equation (2.18) and the equilibrium equations (2.59). These are 4 equations with 4 variables: p , u_x , u_y and u_z . The volume strain ε_{vol} is not an independent variable, see eq. (2.60).

The initial conditions are that the pore pressure p and the three displacement components are given at a certain time (say $t = 0$). The boundary conditions must be that along the boundary 4 conditions are given. One condition applies to the pore fluid: either the pore pressure or the flow rate normal to the boundary must be specified. The other three conditions refer to the solid material: either the 3 surface tractions or the 3 displacement components must be prescribed (or some combination). Many solutions of the consolidation equations have been published (Schiffman, 1984), mainly for bodies of relatively simple geometry (half-spaces, half-planes, cylinders, spheres, etc.).

2.6 Drained deformations

In some cases the analysis of consolidation is not really necessary because the duration of the consolidation process is short compared to the time scale of the problem considered. This can be investigated by evaluating the expression $c_v t/h^2$, where h is the average drainage length, and t is a characteristic time. When the value of this parameter is large compared to 1, see eq. (2.51), the consolidation process will be finished after a time t , and consolidation may be disregarded. In such cases the behaviour of the soil is said to be *fully drained*. No excess pore pressures need to be considered for the analysis of the behaviour of the soil. Problems for which consolidation is so fast that it can be neglected are for instance the building of an embankment or a foundation on a sandy subsoil, provided that the smallest dimension of the structure, which determines the drainage length, is not more than say a few meters.

2.7 Undrained deformations

Quite another class of problems is concerned with the rapid loading of a soil of low permeability (a clay layer). Then it may be that there is hardly any movement of the fluid, and the consolidation process can be simplified in the following way. The basic equation involving the time scale is the storage equation (2.11),

$$-\frac{\partial \varepsilon_{vol}}{\partial t} = n\beta \frac{\partial p}{\partial t} + \nabla \cdot \mathbf{q}. \quad (2.62)$$

If this equation is integrated over a short time interval one obtains

$$-\Delta \varepsilon_{vol} = n\beta \Delta p + \int_0^{\Delta t} \nabla \cdot \mathbf{q} dt. \quad (2.63)$$

The last term in the right hand side represents the net outward flow, over a time interval Δt . When the permeability is very small, and the time step Δt is also very small, this term will be very small, and may be neglected. If the volume strain ε_{vol} and the pore pressure p are considered to be incremental values, with respect to their initial values before application of the load, one may now write

$$-p = \frac{\varepsilon_{vol}}{n\beta}. \quad (2.64)$$

This expression enables to eliminate the pore pressure from the other equations, such as the equations of equilibrium (2.59). This gives

$$\begin{aligned} (\lambda^* + \mu) \frac{\partial \varepsilon_{vol}}{\partial x} + \mu \nabla^2 u_x + f_x &= 0, \\ (\lambda^* + \mu) \frac{\partial \varepsilon_{vol}}{\partial y} + \mu \nabla^2 u_y + f_y &= 0, \\ (\lambda^* + \mu) \frac{\partial \varepsilon_{vol}}{\partial z} + \mu \nabla^2 u_z + f_z &= 0, \end{aligned} \quad (2.65)$$

where

$$\lambda^* = \lambda + \frac{1}{n\beta}. \quad (2.66)$$

It may be noted that these equations are completely similar to the equations of equilibrium for an elastic material, except that the Lamé constant λ has been replaced by λ^* .

Combination of eqs. (2.54) and (2.55) with (2.64) leads to the following relations between the total stresses and the displacements

$$\begin{aligned} \sigma_{xx} &= -\lambda^* \varepsilon_{vol} - 2\mu \varepsilon_{xx}, & \sigma_{xy} &= -2\mu \varepsilon_{xy}, & \sigma_{xz} &= -2\mu \varepsilon_{xz}, \\ \sigma_{yy} &= -\lambda^* \varepsilon_{vol} - 2\mu \varepsilon_{yy}, & \sigma_{yz} &= -2\mu \varepsilon_{yz}, & \sigma_{yx} &= -2\mu \varepsilon_{yx}, \\ \sigma_{zz} &= -\lambda^* \varepsilon_{vol} - 2\mu \varepsilon_{zz}, & \sigma_{zx} &= -2\mu \varepsilon_{zx}, & \sigma_{zy} &= -2\mu \varepsilon_{zy}. \end{aligned} \quad (2.67)$$

These equations also correspond exactly to the standard relations between stresses and displacements from the classical theory of elasticity, again with the exception that λ must be replaced by λ^* . It may be concluded that the total stresses and the displacements are determined by the equations of the theory of elasticity, except that the Lamé constant λ must be replaced by λ^* . The other Lamé constant μ remains unaffected. This type of approach is called an *undrained* analysis.

In terms of the compression modulus K and the shear modulus G the modified parameters are

$$K^* = K + \frac{1}{n\beta}, \quad G^* = G. \quad (2.68)$$

For an incompressible fluid ($\beta = 0$) the compression modulus is infinitely large, which is in agreement with the physical basis of the analysis. The grains and the fluid have been assumed to be incompressible, and the process is so fast that no drainage can occur. In that case the soil must indeed be incompressible. In an undrained analysis the material behaves with a shear modulus equal to the drained shear modulus, but with a compression modulus that is practically infinite. In terms of shear modulus and Poisson's ratio, one may say that Poisson's ratio ν is (almost) equal to 0.5 when the soil is undrained.

As an example one may consider the case of a circular foundation plate on a semi-infinite elastic porous material, loaded by a total load P . According to the theory of elasticity the settlement of the plate is

$$w_\infty = \frac{P(1 - \nu^2)}{ED}, \quad (2.69)$$

where D is the diameter of the plate. This is the settlement if there were no pore pressures, or when all the pore pressures have been dissipated. In terms of the shear modulus G and Poisson's ratio ν this formula may be written as

$$w_\infty = \frac{P(1 - \nu)}{2GD}. \quad (2.70)$$

This is the settlement after the consolidation process has been completed. At the moment of loading the material reacts as if $\nu = \frac{1}{2}$, so that the immediate settlement is

$$w_0 = \frac{P}{4GD}. \quad (2.71)$$

This shows that the ratio of the immediate settlement to the final settlement is

$$\frac{w_0}{w_\infty} = \frac{1}{2(1 - \nu)}. \quad (2.72)$$

Thus the immediate settlement is about 50 % of the final settlement, or more. The consolidation process will account for the remaining part of the settlement, which will be less than 50 %.

2.8 Uncoupled consolidation

In general the system of equations of three-dimensional consolidation involves solving the storage equation together with the three equations of equilibrium, simultaneously, because these equations are coupled. This is a formidable task, and many researchers have tried to simplify this procedure. It would be very convenient, for instance, if it could be shown that in the storage equation

$$-\frac{\partial \varepsilon_{vol}}{\partial t} = n\beta \frac{\partial p}{\partial t} - \nabla \cdot \left(\frac{k}{\gamma_w} \nabla p \right). \quad (2.73)$$

the first term can be expressed as

$$\frac{\partial \varepsilon_{vol}}{\partial t} = \alpha \frac{\partial p}{\partial t}, \quad (2.74)$$

because then the equation reduces to the form

$$(\alpha + n\beta) \frac{\partial p}{\partial t} = \nabla \cdot \left(\frac{k}{\gamma_w} \nabla p \right), \quad (2.75)$$

which is the classical diffusion equation, for which many analytical solutions are available. The system of equations is then uncoupled, in the sense that first the pore pressure can be determined from eq. (2.75), and then later the deformation problem can be solved using the equations of equilibrium, in which then the gradient of the pore pressure acts as a known body force.

For an isotropic material it may be assumed, in general, that the volume strain ε_{vol} is a function of the isotropic effective stress σ'_0 ,

$$\sigma'_0 = \frac{\sigma'_{xx} + \sigma'_{yy} + \sigma'_{zz}}{3}. \quad (2.76)$$

For a linear material the relation may be written as

$$\sigma'_0 = -K\varepsilon_{vol}, \quad (2.77)$$

where K is the compression modulus, and the minus sign is needed because of the different sign conventions for stresses and strains. The effective stress is the difference between total stress and pore pressure, and thus one may write

$$\sigma_0 - p = -K\varepsilon_{vol}, \quad (2.78)$$

Differentiating this with respect to time gives

$$\frac{\partial \sigma_0}{\partial t} - \frac{\partial p}{\partial t} = -K \frac{\partial \varepsilon_{vol}}{\partial t}. \quad (2.79)$$

If the isotropic total stress is constant in time, then there indeed appears to be a relation of the type (2.74), with

$$\alpha = \frac{1}{K}. \quad (2.80)$$

That the isotropic total stress may be constant in certain cases is not unrealistic. In many cases consolidation takes place while the loading of the soil remains constant, and although there may be a certain redistribution of stress, it may well be assumed that the changes in total stress will be small. A complete proof is very difficult to give, however, and it is also difficult to say under what conditions the approximation is acceptable. Various solutions of coupled three-dimensional problems have been obtained, and in many cases a certain difference with the uncoupled solution has been found. Sometimes there is even a very pronounced difference in behaviour for small values of the time, in the sense that sometimes the pore pressures initially show a certain increase, before they dissipate. This is the Mandel-Cryer effect, which is a typical consequence of the coupling effect. When the pore pressures at the boundary start to dissipate the local deformation may lead to an immediate effect in other parts of the soil body, and this may lead to an additional pore pressure. In the long run the pore pressures always dissipate, however, and the difference with the uncoupled solution then is often not important. Therefore an uncoupled analysis may be a good first approximation, if it is realized that local errors may occur, especially for short values of time.

An important class of problems in which an uncoupled analysis is justified is the case where it can be assumed that the horizontal deformations will be negligible, and the vertical total stress remains constant. In the case of a soil layer of large horizontal extent, loaded by a constant surface load, this may be an acceptable set of assumptions. Actually, the equations for this case have already been presented above, see the derivation of eq. (2.23). If the horizontal deformations are set equal to zero, it follows that the volume strain is equal to the vertical strain,

$$\varepsilon_{vol} = \varepsilon_{zz}. \quad (2.81)$$

For a linear elastic material the vertical strain can be related to the vertical effective stress by the formula

$$\sigma'_{zz} = -(\lambda + 2\mu) \varepsilon_{zz}, \quad (2.82)$$

see eq. (2.55). Because the effective stress is the difference of the total stress and the pore pressure it now follows that

$$\sigma_{zz} - p = -(\lambda + 2\mu) \varepsilon_{zz}, \quad (2.83)$$

and thus, if the total stress σ_{zz} is constant in time,

$$\frac{\partial p}{\partial t} = (\lambda + 2\mu) \frac{\partial \varepsilon_{vol}}{\partial t}, \quad (2.84)$$

which is indeed of the form (2.74), with now

$$\alpha = \frac{1}{\lambda + 2\mu}. \quad (2.85)$$

It may be concluded that in this case, of zero lateral deformation and constant vertical total stress, the consolidation equations are uncoupled. The basic differential equation is the diffusion equation (2.75). If the medium is homogeneous, the coefficient k/γ_w is constant in space, and then the differential equation reduces to the form

$$\frac{\partial p}{\partial t} = c_v \nabla^2 p, \quad (2.86)$$

where ∇^2 is Laplace's operator,

$$\nabla^2 = \frac{\partial}{\partial x^2} + \frac{\partial}{\partial y^2} + \frac{\partial}{\partial z^2}, \quad (2.87)$$

and c_v is the consolidation coefficient,

$$c_v = \frac{k}{(\alpha + n\beta)\gamma_w}. \quad (2.88)$$

In the next section a solution of the differential equation will be presented.

2.9 Radial consolidation

One of the simplest non-trivial examples is that of the consolidation of a cylinder, see figure 2.7. It is assumed that in the cylinder an excess pore pressure p_0 has been generated, and that consolidation occurs due to flow in radial direction, towards a drainage layer surrounding the cylinder.

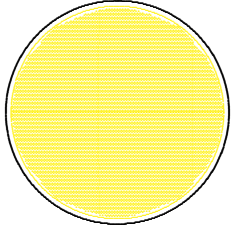

Figure 2.7: Cylinder.

In the case of radially symmetric flow it seems natural to use polar coordinates, and if it is assumed that there is flow only in the plane perpendicular to the axis of the cylinder, the basic differential equation (2.86) is

$$\frac{\partial p}{\partial t} = c_v \left(\frac{\partial p}{\partial r^2} + \frac{1}{r} \frac{\partial p}{\partial r} \right). \quad (2.89)$$

A straightforward method of solution of this type of equation is by the Laplace transform method (see Churchill, 1972; or Appendix A). If the Laplace transform \bar{p} of the pressure p is defined as

$$\bar{p} = \int_0^\infty p \exp(-st) dt, \quad (2.90)$$

then the transformed problem is, when the pore pressure at time $t = 0$ is p_0 , throughout the cylinder,

$$\frac{d^2 \bar{p}}{dr^2} + \frac{1}{r} \frac{d\bar{p}}{dr} - \frac{s}{c_v} \bar{p} = -\frac{p_0}{c_v}. \quad (2.91)$$

The general solution of this problem is

$$\bar{p} = \frac{p_0}{s} + AI_0(qr) + BK_0(qr), \quad (2.92)$$

where $q = \sqrt{s/c_v}$ and $I_0(x)$ and $K_0(x)$ are modified Bessel functions of order zero and the first and second kind, respectively. The solution satisfying the boundary conditions that the pressure is zero along the outer boundary $r = a$, and that the pore pressure is not singular in the origin, is

$$\bar{p} = \frac{p_0}{s} - \frac{p_0}{s} \frac{I_0(qr)}{I_0(qa)}. \quad (2.93)$$

The inverse transform of this expression can be obtained by the complex inversion integral (Churchill, 1972), or in a more simple, although less rigorous way, by application of Heaviside's expansion theorem (Appendix A). The derivation proceeds in the same way as in the case of one-dimensional consolidation considered above, see the derivation of eq. (2.42). The result is

$$\frac{p}{p_0} = 2 \sum_{k=1}^{\infty} \frac{J_0(\alpha_k r/a)}{\alpha_k J_1(\alpha_k)} \exp(-\alpha_k^2 ct/a^2), \quad (2.94)$$

where $J_0(x)$ and $J_1(x)$ are Bessel functions of the first kind and order zero and one, respectively, and where the values α_k indicate the zeroes of $J_0(x)$. These are tabulated, for instance, by Abramowitz & Stegun (1964). The solution (2.94) can be found in many textbooks on the Laplace transform or on heat conduction, see for instance Churchill (1972).

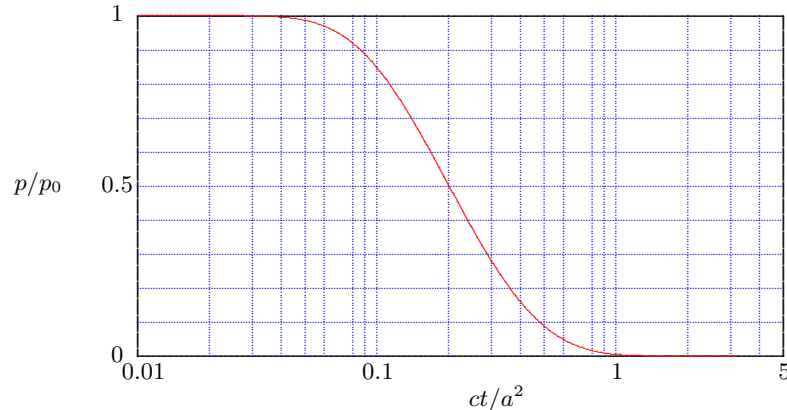

Figure 2.8: Pore pressure in center of cylinder.

The pore pressure in the center of the cylinder is shown in figure 2.8 as a function of time. It may be interesting to mention that the coupled solution shows a small increase of the pore pressure in the center shortly after the start of consolidation (De Leeuw, 1964). This is the Mandel-Cryer effect (Mandel, 1953; Cryer, 1963), which is typical of three-dimensional consolidation. This coupling effect has not been taken into account here, by assuming a simplification of the consolidation equations. The solution given here deviates considerably from the complete three-dimensional solution. For this case a physical explanation of the Mandel-Cryer effect is that in the beginning only the outer ring of the cylinder will be drained. The loss of water in this ring leads to a tendency for it to shrink, which in its turn leads to a compression of the core of the cylinder, where no drainage is possible yet. Only after some time can the draining effect influence the pore pressures in the core, which then also will dissipate. Comparison of the coupled solution with the uncoupled solution shown in figure 2.8 shows that in

the uncoupled solution the dissipation of the pore pressures is a little too fast. And an initial pore pressure increase is not observed.

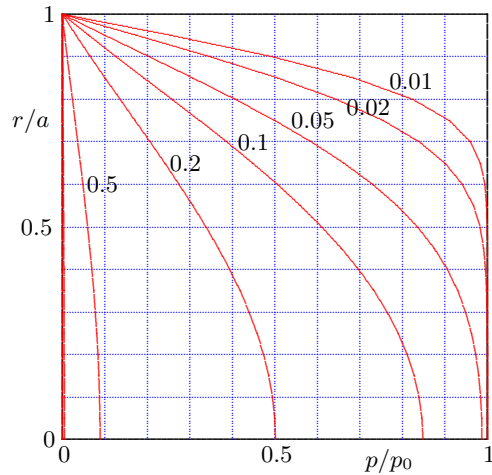

Figure 2.9: Analytical solution of radial consolidation.

The distribution of the pore pressures over the radial distance r is shown, for various values of the dimensionless time parameter ct/a^2 in figure 2.9. Comparison with the solution for the one-dimensional case, see figure 2.3, shows that in the beginning the consolidation process is practically the same, but at later times the radial consolidation goes significantly faster. This can be understood by noting that in the beginning only the areas close to the draining surface are drained, in which case the shape of the boundary is not important. In later stages the core of the sample must be drained, and in the radial case this contains considerably less material, so that a smaller amount of water is to be drained.

Problems

2.1 It is known from Laplace transform theory that an approximation for small values of the time t can often be obtained by taking the transformation parameter s very large. Apply this theorem to the solution of the one-dimensional problem, eq. (2.36), by assuming that s is very large, and then determine the inverse transform from a table of Laplace transforms.

2.2 Apply the same theorem to the solution of the problem of radial consolidation of a massive sphere, by taking s very large in the solution (2.93), and then determining the inverse transform. Note that this leads to precisely the same approximate solution for small values of the time t as in the previous problem.

Chapter 3

SEA BED RESPONSE TO CYCLIC LOADS

An application of the theory of consolidation is the determination of the response of a sea bed to water waves in the sea, see figure 3.1. The case of a single wave propagated along the sea bottom has been discussed by Yamamoto *et al.* (1978) and Madsen (1978). In this chapter the case

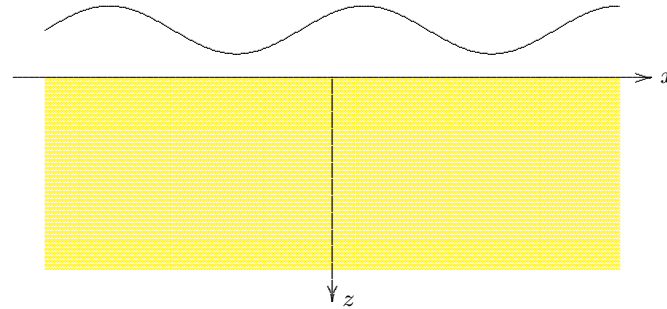

Figure 3.1: Waves over a sea bed.

of a standing wave will be discussed (Verruijt, 1982). Particular attention will be paid to the limiting cases of very long and very short wave lengths.

The cyclic character of the shear stresses in the soil may give rise to an additional build-up of pore pressures in each cycle. This may lead to liquefaction of the soil (Bjerrum, 1973). This effect is studied in the final section of this chapter.

3.1 Basic equations

For the description of the deformations and stresses in a poro-elastic sea bed due to surface loading the basic equations are the equations of linear consolidation. These are the storage equation,

$$-\frac{\partial e}{\partial t} = n\beta \frac{\partial p}{\partial t} - \nabla \cdot \left(\frac{k}{\gamma_w} \nabla p \right), \quad (3.1)$$

and the equations of equilibrium,

$$\begin{aligned}
 (\lambda + \mu) \frac{\partial e}{\partial x} + \mu \nabla^2 u_x + f_x - \frac{\partial p}{\partial x} &= 0, \\
 (\lambda + \mu) \frac{\partial e}{\partial y} + \mu \nabla^2 u_y + f_y - \frac{\partial p}{\partial y} &= 0, \\
 (\lambda + \mu) \frac{\partial e}{\partial z} + \mu \nabla^2 u_z + f_z - \frac{\partial p}{\partial z} &= 0.
 \end{aligned} \tag{3.2}$$

If the water wave considered is independent of the y -direction, it may be assumed that the soil deforms under plane strain conditions, i.e. $u_y = 0$. Furthermore the body force will be disregarded, which means that the stresses due to the weight of the soil itself are assumed to be included in the initial state of stress. Finally, for reasons of future simplicity, the material parameters are slightly modified. Instead of the Lamé constant λ a dimensionless parameter m will be used, defined by

$$m = \frac{1}{1 - 2\nu} = \frac{\lambda + \mu}{\mu} = \frac{K + \frac{1}{3}G}{G}. \tag{3.3}$$

For an incompressible material the value of m is infinitely large, the smallest possible value of m is $\frac{1}{3}$.

The influence of the compressibility of the fluid is expressed by a dimensionless parameter θ , defined by

$$\theta = n\beta\mu. \tag{3.4}$$

This parameter expresses the compressibility of the fluid in terms of the shearing flexibility of the soil. It is zero when the fluid is incompressible.

Furthermore the consolidation coefficient c_v is defined as

$$c_v = \frac{k}{\gamma_w} \mu (1 + m). \tag{3.5}$$

The basic equations can now be rewritten as

$$(1 + m)\mu \frac{\partial e}{\partial t} + \theta(1 + m) \frac{\partial p}{\partial t} - c_v \nabla^2 p = 0, \tag{3.6}$$

$$m\mu \frac{\partial e}{\partial x} + \mu \nabla^2 u_x - \frac{\partial p}{\partial x} = 0, \tag{3.7}$$

$$m\mu \frac{\partial e}{\partial z} + \mu \nabla^2 u_z - \frac{\partial p}{\partial z} = 0. \tag{3.8}$$

3.2 Boundary conditions

The region considered is the half plane $z > 0$, see figure 3.1. On the surface $z = 0$ a load is applied in the form of a standing wave, in the normal stress and the pore pressure. Thus the boundary conditions are supposed to be

$$z = 0 : \quad p = \tilde{p} \exp(i\omega t) \cos(\lambda x), \quad (3.9)$$

$$z = 0 : \quad \sigma_{zz} = \tilde{q} \exp(i\omega t) \cos(\lambda x), \quad (3.10)$$

$$z = 0 : \quad \sigma_{zx} = 0. \quad (3.11)$$

Because these boundary conditions involve the stresses, the relations between these stresses and the displacements are also needed. These are

$$\sigma_{xx} = -(m-1)\mu e - 2\mu \frac{\partial u_x}{\partial x} + p, \quad (3.12)$$

$$\sigma_{zz} = -(m-1)\mu e - 2\mu \frac{\partial u_z}{\partial z} + p, \quad (3.13)$$

$$\sigma_{zx} = -\mu \left(\frac{\partial u_z}{\partial x} + \frac{\partial u_x}{\partial z} \right). \quad (3.14)$$

3.3 Solution

The general solution of the problem described by the equations presented in the previous section, vanishing for $z \rightarrow \infty$, is

$$p/\mu = -\{2\lambda A_1 \exp(-\lambda z) + (1+m)(\alpha^2 - \lambda^2)A_3 \exp(-\alpha z)\} \exp(i\omega t) \cos(\lambda x), \quad (3.15)$$

$$u_x = \{[A_2 - A_1(1+m\theta)\lambda z] \exp(-\lambda z) + \lambda A_3 \exp(-\alpha z)\} \exp(i\omega t) \sin(\lambda x), \quad (3.16)$$

$$u_z = \{[A_2 - A_1(1+2\theta+m\theta) - A_1(1+m\theta)\lambda z] \exp(-\lambda z) + \alpha A_3 \exp(-\alpha z)\} \exp(i\omega t) \cos(\lambda x), \quad (3.17)$$

where α is defined by

$$\alpha^2 = \lambda^2 + \frac{i\omega}{c_v}(1+\theta+m\theta), \quad \mathcal{R}e(\alpha) > 0. \quad (3.18)$$

The volume strain is

$$e = \{2\lambda\theta A_1 \exp(-\lambda z) - (\alpha^2 - \lambda^2)A_3 \exp(-\alpha z)\} \exp(i\omega t) \cos(\lambda x), \quad (3.19)$$

The two stress components needed for the boundary conditions are

$$\frac{\sigma_{zx}}{2\mu} = \lambda\{[A_2 - A_1\theta - A_1(1+m\theta)\lambda z] \exp(-\lambda z) + \alpha A_3 \exp(-\alpha z)\} \exp(i\omega t) \sin(\lambda x), \quad (3.20)$$

$$\frac{\sigma_{zz}}{2\mu} = \lambda\{[A_2 - A_1(1+\theta+m\theta) - A_1(1+m\theta)\lambda z] \exp(-\lambda z) + \lambda A_3 \exp(-\alpha z)\} \exp(i\omega t) \cos(\lambda x), \quad (3.21)$$

It can be verified without essential difficulties that this solution satisfies the differential equations (3.6) – (3.8). The reader is encouraged to verify this statement.

The three constants A_1 , A_2 and A_3 appearing in the solution can be determined from the boundary conditions (3.9) – (3.11). The result is

$$A_1 = \frac{\tilde{q}(1+m)(\alpha+\lambda) - 2\tilde{p}\lambda}{2\mu\lambda[(1+m)(1+m\theta)(\alpha+\lambda) - 2\lambda]}, \quad (3.22)$$

$$A_2 = \frac{\tilde{q}[(1+m)(\alpha^2 - \lambda^2)\theta + 2\alpha\lambda] - 2\tilde{p}\lambda[\alpha(1+m\theta) + \theta(\alpha - \lambda)]}{2\mu\lambda(\alpha - \lambda)[(1+m)(1+m\theta)(\alpha + \lambda) - 2\lambda]}, \quad (3.23)$$

$$A_3 = \frac{\tilde{p}(1+m\theta) - \tilde{q}}{\mu(\alpha - \lambda)[(1+m)(1+m\theta)(\alpha + \lambda) - 2\lambda]}. \quad (3.24)$$

Again the reader is encouraged to verify that with these values the boundary conditions are indeed satisfied. Two special cases will be studied in some more detail below.

3.4 Water waves

The solution given above is for standing waves, as indicated by the factor $\exp(i\omega t) \cos(\lambda x)$ in the boundary conditions. They can be transformed with little difficulty into solutions for a propagating wave, by replacing that factor by a factor $\cos(\omega t - \lambda x)$. A case of particular interest is that of a wave in the water just above the sea bed. In that case the total stress at the surface is equal to the pore pressure. In the formulas this can be accomplished by taking $\tilde{q} = \tilde{p}$. In this case one obtains

$$2\lambda\mu A_1 = \frac{\tilde{p}[(1+m)(\alpha+\lambda) - 2\lambda]}{(1+m)(1+m\theta)(\alpha+\lambda) - 2\lambda}, \quad (3.25)$$

$$\mu(1+m)(\alpha^2 - \lambda^2)A_3 = \frac{\tilde{p}(1+m)(\alpha+\lambda)m\theta}{(1+m)(1+m\theta)(\alpha+\lambda) - 2\lambda}, \quad (3.26)$$

Substitution of these values into eq. (3.15) gives

$$\frac{p}{\tilde{p}} = \frac{[(1+m)(\alpha+\lambda) - 2\lambda] \exp(-\lambda z) + (1+m)(\alpha+\lambda)m\theta \exp(-\alpha z)}{(1+m)(1+m\theta)(\alpha+\lambda) - 2\lambda} \cos(\omega t - \lambda x). \quad (3.27)$$

In order to further investigate this solution it is useful to reconsider the parameter α in the solution. According to eq. (3.18) it is defined by

$$\alpha^2 = \lambda^2 + \frac{i\omega}{c_v}(1 + \theta + m\theta), \quad \mathcal{Re}(\alpha) > 0. \quad (3.28)$$

From this it follows that

$$\alpha = \lambda \sqrt{1 + i\psi(1 + \theta + m\theta)}, \quad \mathcal{Re}(\alpha) > 0. \quad (3.29)$$

where now ψ is a dimensionless wave parameter, defined by

$$\psi = \frac{\omega}{c_v \lambda^2}. \quad (3.30)$$

In terms of a wave length L ($L = 2\pi/\lambda$) and a period T ($T = 2\pi/\omega$) the definition of ψ can be written as

$$\psi = \frac{L^2}{2\pi c_v T}. \quad (3.31)$$

The value of this parameter is determined by the consolidation coefficient. A small wave period (or a large wave length) corresponds to a type of undrained behaviour, consolidation then cannot have a large influence. The value of ψ then is very large. In the case of very slow waves (or waves with a very short wave length) the behaviour of the soil is of a drained character. The value of ψ then is very small. These special cases will be considered separately.

It may be illustrative to determine what the wave length must be in order to be considered "long" in the sense of the wave parameter ψ . Average values of the consolidation coefficient for sand are

$$c_v = 0.01 \text{ m}^2/\text{s} \dots 0.1 \text{ m}^2/\text{s}.$$

The most important waves on the North Sea have a period of about 10 seconds. This means that for waves with a wave length longer than 10 m the value of the wave parameter ψ will be 16 or larger. For clayey soils the consolidation coefficient will be much smaller, and then the value of ψ will be even larger. It seems that for the most important sea waves the value of the wave parameter ψ can be assumed to be much larger than 1.

Long waves

If the wave parameter ψ is very large, the value of the parameter α is very large compared to λ . The formula (3.27) then reduces to

$$\psi \gg 1 : \frac{p}{\tilde{p}} = \frac{\exp(-\lambda z) + m\theta \exp(-\alpha z)}{1 + m\theta} \cos(\omega t - \lambda x). \quad (3.32)$$

Because α is complex, the second term in the numerator will give rise to a phase shift. The effect of this term will be rapidly attenuated with depth, however, because the real part of α is large compared to λ .

Incompressible fluid

Another interesting case is when the fluid is incompressible. In that case $\theta = 0$, and the solution (3.27) reduces to

$$\theta = 0 : \frac{p}{\tilde{p}} = \exp(-\lambda z) \cos(\omega t - \lambda x). \quad (3.33)$$

This means that the variations of the pore pressure are simply attenuated with depth, without any phase shift.

The same approximation (3.33) applies when the wave parameter ψ is very small, i.e. for short waves. In all these cases the pore pressures satisfy the Laplace equation $\nabla^2 p = 0$.

In this case the volumetric strain is zero, so that the isotropic effective stress is also zero,

$$\sigma'_o = \frac{\sigma'_{xx} + \sigma'_{zz}}{2} = 0. \quad (3.34)$$

This means that the isotropic effective stress in the soil is not affected by the wave. It should be noted that the effect of the body force (gravity) is supposed to be incorporated in the initial stresses. These can be assumed to be

$$\sigma'_o = \frac{1 + 2K_o}{3} \gamma' z, \quad (3.35)$$

where γ' is the submerged volumetric weight,

$$\gamma' = \gamma - \gamma_w, \quad (3.36)$$

and K_o is the coefficient of lateral stress.

Another interesting quantity is the maximum shear stress τ ,

$$\tau = \sqrt{\left(\frac{\sigma'_{xx} - \sigma'_{zz}}{2}\right)^2 + \sigma'^2_{xy}}. \quad (3.37)$$

This quantity is now found to be

$$\tau = \tilde{p}\lambda z \exp(-\lambda z) \exp(i\omega t), \quad (3.38)$$

independent of x . The maximum value of this shear stress occurs at a depth for which $\lambda z = 1$. Near the surface the shear stress increases linearly,

$$\lambda z \ll 1 : \quad \tau = \tilde{p}\lambda z \exp(i\omega t). \quad (3.39)$$

For the stability of the sea bed the critical quantity is the ratio of shear stress to isotropic stress, which should not reach $\tan \phi$, where ϕ is the friction angle of the soil. Assuming that the initial state of stress is isotropic ($K_o = 1$), one now obtains

$$\lambda z \ll 1 : \quad \frac{\tau}{\sigma'_o} = \frac{\tilde{p}\lambda}{\gamma'}. \quad (3.40)$$

When this ratio approaches $\tan \phi$ the sea bed may become unstable. It should be noted that this situation may occur over a large depth, when the wave length is large. It should also be noted that these considerations apply only if the fluid is completely incompressible. In case of a compressible fluid the formulas are more complicated, but it can be expected that the influence of the wave will be less then.

3.5 Approximation of the differential equation

The importance of the wave parameter ψ for the character of the solution can also be understood by a further investigation of the storage equation (3.1),

$$(1+m)\mu \frac{\partial e}{\partial t} + \theta(1+m) \frac{\partial p}{\partial t} - c_v \nabla^2 p = 0. \quad (3.41)$$

If a wave type solution of the form

$$e = \tilde{e} \exp(i\omega t - i\lambda x), \quad (3.42)$$

$$p = \tilde{p} \exp(i\omega t - i\lambda x), \quad (3.43)$$

is substituted, the resulting equation is

$$i\psi(1+m)\mu\lambda^2(\tilde{e} + n\beta\tilde{p}) - \left(\frac{d^2\tilde{p}}{dy^2} - \lambda^2\tilde{p}\right) = 0. \quad (3.44)$$

It follows from this equation that if $\psi \ll 1$ the first terms may be disregarded, and the pore pressure will satisfy the Laplace equation.

On the other hand if $\psi \gg 1$ the first terms dominate, and the relation between pore pressure and volume strain will be

$$\psi \gg 1 : \quad e + n\beta p = 0, \quad (3.45)$$

indicating undrained behaviour.

3.6 Cyclic volume change

In the previous section the behaviour of the soil was considered to be fully elastic, i.e. reversible. This is often a rather poor approximation of the real behaviour of soils, as it is well known that soils very often exhibit irreversible (plastic) deformations. In order to study one of the effects due to such plastic deformations a simplified problem will be considered in this section. The problem again refers to cyclic loading of a saturated soil, in the form of a column of sand, with an impermeable bottom, see figure 3.2. The load is supposed to be cyclic, with a period T ,

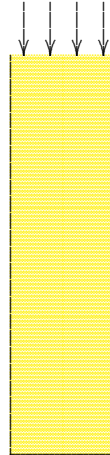

Figure 3.2: Cyclic loading of a column.

but its nature is not specified. It is assumed, however, that the load can be characterized by a maximum shear stress level τ_0 . This shear stress may be generated in the soil due to a vertical load with a constant horizontal stress (as in triaxial testing) or due to loading by a shear stress (as in pure shear testing). It may also be produced by water waves over the surface.

The main new effect that is now introduced is the generation of pore pressures in undrained cyclic shear tests, as noted by Bjerrum (1973). In such tests, or in undrained cyclic triaxial tests, it is often observed that after each full cycle of loading a small excess pore pressure remains. This is supposed to be due to the phenomenon that a dry soil will tend to show a small volumetric compression after each full cycle of loading, whatever the type of loading is. In a saturated soil without drainage this tendency is prevented by the water in the pores, with an excess pore pressure as its result. Although the pore pressure after one cycle usually is very small, a considerable pore pressure may be built up if the

number of cycles is very large. As a first approximation the pore pressure generation can be considered to be proportional to the number of cycles N , and to the applied shear stress τ_0 ,

$$p = B\tau_0 N, \quad (3.46)$$

where B is the dimensionless coefficient indicating the ratio of pore pressure to shear load per cycle. For dense sands it is very small, but values up to 10^{-3} have been reported for loose sands. If the load is written as

$$\tau = \tau_0 \sin\left(\frac{2\pi t}{T}\right), \quad (3.47)$$

the number of cycles can be identified with t/T , so that eq. (3.46) can also be written as

$$p = \frac{B\tau_0 t}{T}. \quad (3.48)$$

This means that

$$\frac{\partial p}{\partial t} = \frac{B\tau_0}{T}. \quad (3.49)$$

Written in this form the effect can be introduced into the one dimensional consolidation equation, with the result

$$\frac{\partial p}{\partial t} = c_v \frac{\partial^2 p}{\partial z^2} + \frac{B\tau_0}{T}, \quad (3.50)$$

where it has been assumed that the load level is the same all along the column, so that the pore pressure generation effect is also constant along the column.

The boundary conditions are supposed to be

$$z = 0 : p = 0, \quad (3.51)$$

and

$$z = L : \frac{\partial p}{\partial z} = 0, \quad (3.52)$$

The first boundary condition indicates that the surface of the soil is fully drained, and the second boundary condition indicates an impermeable layer at a depth L .

Before attempting to solve the partial differential equation (3.50) it is interesting to note that the problem has a steady state solution, which may be reached after a large number of loading cycles. This steady state solution can be obtained by assuming that p is independent of time, and then integrating the ordinary differential equation obtained from (3.50) when $\partial p/\partial t = 0$. If the boundary conditions are used to determine the integration constants in the solution the final result is

$$\frac{p}{p_0} = \frac{z(2L - z)}{L^2}, \quad (3.53)$$

where p_0 is the final pore pressure at the bottom,

$$p_0 = \frac{B\tau_0 L^2}{2c_v T}. \quad (3.54)$$

The steady state pore pressure appears to be of parabolic shape. In this state the generation of pore pressures due to cyclic loading is balanced by the dissipation due to the flow.

The non-steady solution can be obtained by solving the differential equation (3.50). This can be done using the Laplace transform technique, which will give an exact analytical solution. Without going into the details it may be recorded here that this analytic solution is

$$\frac{p}{p_0} = 1 - \frac{32}{\pi^3} \sum_{k=1}^{\infty} \frac{(-1)^k}{(2k-1)^3} \cos\left[\frac{\pi}{2}(2k-1)\left(1 - \frac{z}{L}\right)\right] \exp\left[-\frac{\pi^2 c_v t}{4L^2}(2k-1)^2\right], \quad (3.55)$$

The problem can also be solved numerically (Verruijt *et al.*, 1997). This enables to study the effect of non-homogeneous soil properties, such as the influence of densification of the top layer of the soil, or the addition of a layer of higher permeability.

A simple approximate solution can be found by assuming that the pore pressure distribution is always parabolic, as suggested by the steady state solution (3.53). Thus it is assumed that one may write, approximately,

$$p = F(t) \frac{z(2L-z)}{2c}. \quad (3.56)$$

where the function $F(t)$ is to be determined. The expression (3.56) satisfies both boundary conditions (3.51) and (3.52), so that the function $F(t)$ must be determined by substitution into the differential equation (3.50). This gives

$$\frac{dF}{dt} z(2L-z) = -2c_v F + \frac{B\tau_0}{T}. \quad (3.57)$$

This equation cannot be satisfied for every value of z , because the left hand side of the equation is a function of z , and the right hand side is not. Therefore the condition that the differential equation must be satisfied is relaxed to the condition that it is satisfied only on the average. Because the average value of the function $z(2L-z)$ over the interval from $z=0$ to $z=L$ is $\frac{2}{3}L^2$ it now follows that the differential equation for F becomes

$$\frac{dF}{dt} = -\frac{3c_v}{L^2} F + \frac{3B\tau_0}{2L^2 T}, \quad (3.58)$$

with the solution

$$F = C \exp\left(-\frac{3c_v t}{L^2}\right) + \frac{B\tau_0}{2c_v T}. \quad (3.59)$$

The integration constant C can be determined from the initial condition, which is assumed to be that the pore pressures are zero at time $t=0$. This gives

$$C = -\frac{B\tau_0}{2c_v T}. \quad (3.60)$$

The final, approximate, solution for the pore pressure now is

$$\frac{p}{p_0} = \frac{z(2L - z)}{L^2} \left[1 - \exp\left(-\frac{3c_v t}{L^2}\right) \right]. \quad (3.61)$$

where p_0 is given by eq. (3.54).

The approximate pore pressure distribution is parabolic (by assumption), with its maximum at the impermeable bottom of the layer, $z = L$. The build-up of the pore pressure at the bottom (p_L) is shown in figure 3.3. The fully drawn line represents the analytic solution (3.55), and the dashed line represents the approximate solution (3.61). It appears that the approximate solution agrees reasonably well with the exact solution.

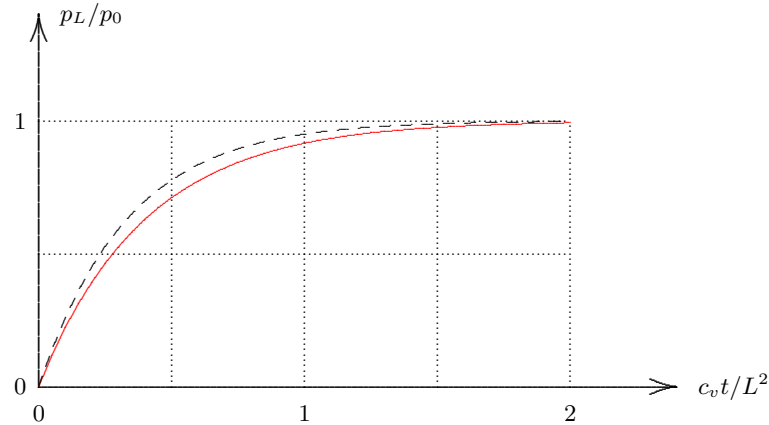

Figure 3.3: Pore pressure build-up.

It should be noted that in the figure only the pore pressure after complete cycles is represented. During each cycle there may be an additional cyclic pore pressure, which is not shown in the figure.

It is interesting to note from formula (3.54) that the final pore pressure depends upon the ratio of the quantities $B\tau_0$, which is the pore pressure generated in a single full cycle, and $c_v T/L^2$, which expresses the dimensionless consolidation time in a cycle. It appears that the pore pressures will be smaller if the permeability is larger, because then the consolidation coefficient c_v is larger. This is in agreement with engineering intuition. In engineering practice the build-up of excess pore pressures in loose sands can be reduced by compaction of the sand (so that the value of the coefficient B is reduced) or by the deposition of a gravel bed. Pipelines are therefore often laid in a trench, which then is filled later with gravel.

In order to assess the risk of liquefaction of the soil the maximum hydraulic gradient at the surface may be evaluated from the steady state

solution. This hydraulic gradient is defined as

$$j = \frac{1}{\gamma_w} \frac{\partial p}{\partial z}. \quad (3.62)$$

From eq. (3.53) it follows that

$$\frac{\partial p}{\partial z} = \frac{2p_0(L-z)}{L^2}. \quad (3.63)$$

At the surface this value has its maximum, $2p_0/L$. The hydraulic gradient at the surface is

$$j = \frac{2p_0}{\gamma_w L} = \frac{B\tau_0 L m_v}{kT}, \quad (3.64)$$

where the definition of the consolidation coefficient has been used,

$$c_v = \frac{k}{m_v} \gamma_w. \quad (3.65)$$

The hydraulic gradient given by (3.64) will give rise to a linear increase of the pore pressures near the surface. The effective stresses will decrease by the same amount, because the total stresses are constant (at least as a first approximation). Thus this additional hydraulic gradient must be compared to the gradient of the effective stresses, which can be written as

$$j' = \frac{\gamma - \gamma_w}{\gamma_w}, \quad (3.66)$$

where γ is the volumetric weight of the soil (grains and water), and γ_w , as before, is the volumetric weight of the water. A normal value of the effective stress gradient is $j' = 1.0$. This means that the hydraulic gradient j , as given by eq. (3.64) must be larger than 1 for the soil to liquefy.

It may finally be mentioned that throughout this section the generation of pore pressures is governed by the very simple linear rule (3.46). In reality the soil will gradually decrease in volume due to drainage, which will make the soil less sensitive to cyclic volume changes. Thus the factor B will in general tend to decrease during the process (this is called preshearing). The analysis presented in this section can be considered to be conservative. In reality the pore pressures will be smaller than those shown in figure 3.3. It can also be expected that after a very long time the drainage effect will dominate the ever decreasing generation of pore pressures, so that the pore pressures will ultimately tend towards zero.

Problems

- 3.1** Determine the maximum vertical gradient of the pore pressure, for the case of pore pressures generated in a semi-infinite linear elastic porous material, see eq. (3.27), or its approximations (3.32) and (3.33).
- 3.2** Derive the analytic solution (3.55), using the Laplace transform method.

Chapter 4

CUTTING FORCES IN SAND

4.1 Introduction

In the early seventies a theoretical model has been developed for the calculation of forces during the cutting process of dense sand, under water, in a research project of Delft Geotechnics and Delft Hydraulics, sponsored by a consortium of dredging companies from the Netherlands (see Van Os & Van Leussen, 1987). The theory combines a number of basic phenomena and ideas, namely consolidation theory for saturated soils, dilatancy of sands, cavitation of water, and a moving coordinate system. Despite the complicated character of the phenomena involved, the theory leads to a relatively simple formula. The form of this formula will be derived in this chapter, using the same basic principles, but in a simplified way. The approach can also be used to predict the behaviour of a continuously failing slope of dense sand, or of loose sand. This last phenomenon is related to liquefaction of sands, and it is also known under the name *flow slides*. It will appear that in this way it is possible to predict the velocity of a moving vertical slope in dense sand.

4.2 Cutting of sand

In the theory of cutting of sand, as originally developed by Van Os (see Van Os & Van Leussen, 1987), one of the basic equations is the *storage equation* from Biot's theory of consolidation, see Biot (1941), De Josselin de Jong (1963) or Verruijt (1984). This equation expresses that

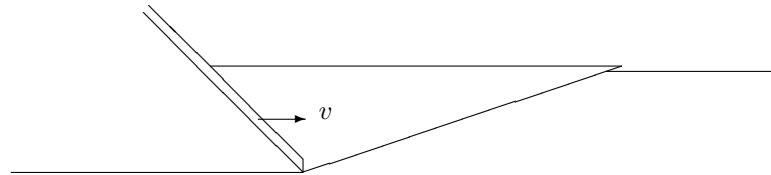

Figure 4.1: The cutting process.

volumetric deformations of the soil must be accompanied by a compression of the pore fluid, or an expulsion of water due to flow. Changes of volume due to compression of the soil particles is neglected, on the basis of the notion that soil deformations are caused by a rearrangement of particles rather than their individual deformations. The storage equation can be written as

$$\frac{\partial e}{\partial t} = -n\beta \frac{\partial p}{\partial t} - \nabla \cdot \mathbf{q} + g. \quad (4.1)$$

In the right hand side of this equation the first term represents the compression of the pore fluid, n being the porosity and β being the compressibility of the fluid. The second term represents the expulsion of the pore fluid, due to flow, and the third represents a possible external supply of fluid. The quantity g is a discharge per unit volume of the soil.

The volumetric strain rate $\partial e/\partial t$ can also be expressed in the change of porosity, using the assumption that the solid particles are incompressible,

$$\frac{\partial e}{\partial t} = \frac{1}{1-n} \frac{\partial n}{\partial t}. \quad (4.2)$$

The compressibility of the pore fluid will be disregarded, i.e. $\beta = 0$. After substitution of Darcy's law into equation (4.1) one obtains

$$\frac{k}{\gamma_w} \nabla^2 p = \frac{1}{1-n} \frac{\partial n}{\partial t} - g. \quad (4.3)$$

In continuous processes such as cutting, it is convenient to introduce a moving coordinate system, with

$$\xi = x - vt, \quad (4.4)$$

where v is the velocity. Equation (4.3) now becomes

$$\frac{k}{\gamma_w} \nabla^2 p = -\frac{v}{1-n} \frac{\partial n}{\partial \xi} - g. \quad (4.5)$$

In the cutting process a cutting blade is moving through the soil, at a velocity v . There is no external supply of water, i.e. $g = 0$. It is postulated, on the basis of experimental evidence obtained in the laboratory, that the deformations of the sand consist of a continuous creation of sliding surfaces, all of the same shape. As an approximation this is now further schematized by assuming that a thin sliding surface is moving, with a velocity v , through the soil mass. Furthermore it is assumed that everywhere in the interior of the soil mass the pore volume is constant (i.e. $e = 0$), except on the slip surface, along which the porosity increases from n to $n + \Delta n$. Hence in this slip surface $\partial n/\partial \xi = -\Delta n/\Delta \xi$, if the thickness of the slip surface is denoted by $\Delta \xi$. The pore pressure p is now governed by the following differential equations

$$P \notin R : \quad \frac{k}{\gamma_w} \nabla^2 p = 0, \quad (4.6)$$

$$P \in R : \quad \frac{k}{\gamma_w} \nabla^2 p = \frac{v}{1-n} \frac{\Delta n}{\Delta \xi}, \quad (4.7)$$

where R is the area of the sliding zone. It should be noted that the dilatancy of the sand has been incorporated here, in a very much simplified way, by the expansion of the soil in the slip surface.

Now consider an alternative problem, of the same geometry as the cutting problem, without volume change, but with a local supply of water in the region R . This problem is described by the equations

$$P \notin R : \quad \frac{k}{\gamma_w} \nabla^2 p = 0, \quad (4.8)$$

$$P \in R : \quad \frac{k}{\gamma_w} \nabla^2 p = -g \quad (4.9)$$

The two problems are mathematically identical if

$$g = -\frac{v}{1-n} \frac{\Delta n}{\Delta \xi}. \quad (4.10)$$

This type of analogy, and its use, have been suggested first by ir. Herman Koning of Delft Geotechnics in the late sixties. In the present case it means that the volume change produced by the cutting process (in which the sand is transformed from a dense state to a much looser state) is simulated by a local withdrawal of water (a withdrawal because g is negative), in order to determine the pore pressures generated by the cutting process. The advantage of the analogy is that the problem seems to be easier to solve when formulated as a problem of local water extraction, using the well known solutions for the influence of a pumping well in an infinite porous medium.

In the present case the solution of the problem can be found by assuming, as a first approximation, that the extraction of water is concentrated at a single point. If the cutting depth is denoted by h , and the width of the blade is b , then the total discharge of water is

$$Q = -ghb\Delta\xi = hb\frac{v\Delta n}{1-n}. \quad (4.11)$$

The solution for a well of discharge Q near a horizontal draining surface can be described by introducing an image well above the draining surface. The solution for the pore pressure will be of the form

$$\frac{p}{\gamma_w} = \frac{Q}{2\pi kb} \ln\left(\frac{r_1}{r_2}\right). \quad (4.12)$$

The ratio r_1/r_2 can be estimated, as an average, to be about 1/4. Thus one obtains, with (4.10) and (4.11),

$$p = -\alpha\gamma_w h \frac{v}{k} \frac{\Delta n}{1-n}. \quad (4.13)$$

In this formula the value of the coefficient α is about $\ln(4)/2\pi \approx 0.22$.

The solution (4.13) expresses that the pore pressures are proportional to the factor v/k , and that they are determined, also in a linear relationship, by the change in porosity Δn . Thus for the cutting process this parameter, which describes the difference in porosity of the natural soil and the soil after cutting, appears to be the governing quantity. The parameter Δn is not a fundamental soil property, but it is related to the dilatancy properties of the soil. It embodies all dilatancy effects when the soil passes from its natural dense state to the loose state in which the soil can be transported by the dredging machine.

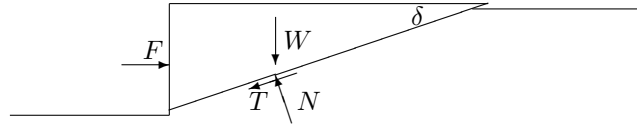

Figure 4.2: Equilibrium of wedge.

The horizontal force on the cutting blade can be determined, as a first approximation, by considering equilibrium of a sliding wedge, see figure 4.2. In this first approximation it is assumed that the shear force along a vertical section through the lower end of the cutting knife is zero. The equations of equilibrium are

$$W = N \cos(\delta) - T \sin(\delta), \quad (4.14)$$

$$F = N \sin(\delta) + T \cos(\delta), \quad (4.15)$$

where δ is the angle of the slip surface with the horizontal direction. The weight W of the wedge is

$$W = \frac{1}{2} \gamma_s b h^2 \cot(\delta), \quad (4.16)$$

in which γ_s is the volumetric weight of the soil mass as a whole, b is the width of the cutting knife, and h is the height of the sliding wedge.

If the wedge slides in upward direction, the shearing force T can be related to the normal force N by the equation

$$T = (N - pbl) \tan(\phi), \quad (4.17)$$

where l is the length of the shear plane, and ϕ is the friction angle of the sand. The pressure p consists of a hydrostatic part, and the additional pressure due to the suction in the soil, as described by eq. (4.13).

Elimination of N , T and W from the equations (4.14), (4.15), (4.16) and (4.17) gives

$$F = \frac{1}{2} \gamma_s b h^2 + \left(\frac{1}{2} \gamma_s b h^2 - p b h \right) \frac{\sin(\phi)}{\sin(\delta) \cos(\phi + \delta)}. \quad (4.18)$$

The value of the horizontal force needed to let the wedge slide over the slip plane appears to depend upon the angle δ . Following Coulomb's original argument, the critical slip plane is the one for which the force is minimal. This minimum will occur if the value of the function in the denominator,

$$f(\delta) = \sin(\delta) \cos(\phi + \delta), \quad (4.19)$$

has a maximum. This function has a maximum for

$$\delta = \frac{\pi}{4} - \frac{\phi}{2}. \quad (4.20)$$

The horizontal force then is

$$F = \frac{1}{2}\gamma_s bh^2 + \left(\frac{1}{2}\gamma_s bh^2 - pbh\right) \frac{2 \sin(\phi)}{1 - \sin(\phi)}. \quad (4.21)$$

The pore pressure p can be written as

$$p = \frac{1}{2}\gamma_w h - \alpha\gamma_w h \frac{v}{k} \frac{\Delta n}{1 - n}. \quad (4.22)$$

In this equation the first term is the (average) hydrostatic pore water pressure along the slip surface, and the third term is the suction due to dilatancy, as expressed by eq. (4.13).

The horizontal force F consists of the sum of the force exerted on the soil by the cutting knife and the force due to the pore water pressure on the vertical plane. Thus one may write

$$F = F' + \frac{1}{2}\gamma_w bh^2. \quad (4.23)$$

With (4.22) and (4.21) it now follows that

$$F' = \frac{1}{2}K_p bh^2(\gamma_s - \gamma_w) + \alpha(K_p - 1)bh^2\gamma_w \frac{v}{k} \frac{\Delta n}{1 - n}, \quad (4.24)$$

where K_p is the coefficient of passive earth pressure,

$$K_p = \frac{1 + \sin \phi}{1 - \sin \phi} \quad (4.25)$$

The first term in equation (4.24) is the classical result for passive earth pressure. The second term is the additional force produced by the suction in the soil, which is a result of the cutting process. It is interesting to note the dependence of this term on the physical parameters, such as the cutting depth h , the cutting velocity v , the permeability k , and especially the porosity change Δn .

As seen above, the pore pressures in the sand are reduced by the cutting process, and thus increase the resistance of the soil to cutting. This cannot continue in an unlimited way, however, because the lowest possible pore pressure is zero, at about which level cavitation will start to occur. If the maximum possible reduction of the pore pressure is denoted by $d\gamma_w$, where d is a certain length (approximately : the water depth, plus 10 m), then the maximum cutting force is

$$F'_{\max} = \frac{1}{2}K_p bh^2(\gamma_s - \gamma_w) + (K_p - 1)bhd\gamma_w \quad (4.26)$$

It should be mentioned that in the original paper (Van Os & Van Leussen, 1987) the calculations are somewhat more sophisticated, both with

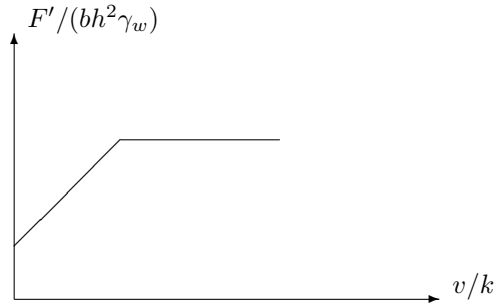

Figure 4.3: Cutting force as a function of velocity.

regard to the shape of the critical slip surface, as to the calculation of the pore pressures. The general form of the equations is the same, however.

The form of the relation between the horizontal cutting force and the velocity is shown in figure 4.3. When the velocity is zero, the force is determined by the classical passive earth resistance. When the velocity increases the force increases linearly, due to the development of the negative pore pressures. The horizontal part of the figure, indicating a constant force, is obtained when cavitation is reached.

4.3 Liquefaction of a slope

The approach used in the previous section can also be used in the analysis of stability of a slope that it is continuously failing. The equations of equilibrium are

$$\frac{\partial \sigma_{xx}}{\partial x} + \frac{\partial \sigma_{yx}}{\partial y} - \gamma_s \cos \alpha = 0, \quad (4.27)$$

$$\frac{\partial \sigma_{xy}}{\partial x} + \frac{\partial \sigma_{yy}}{\partial y} + \gamma_s \sin \alpha = 0. \quad (4.28)$$

The total stresses can be decomposed into effective stresses and pore pressures,

$$\sigma_{xx} = \sigma'_{xx} + p_0 + p, \quad (4.29)$$

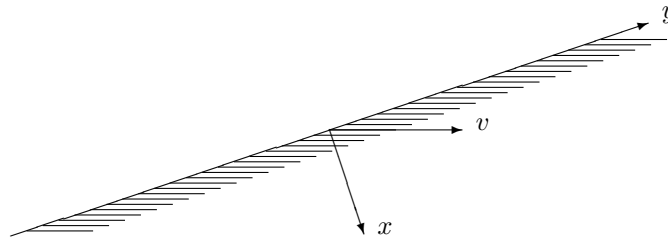

Figure 4.4: Moving slope.

$$\sigma_{yy} = \sigma'_{yy} + p_0 + p, \quad (4.30)$$

where p_0 is the hydrostatic pressure in the water, and p is the excess pore pressure. The hydrostatic pressure can be written as

$$p = A + \gamma_w x \cos \alpha - \gamma_w y \sin \alpha, \quad (4.31)$$

so that the equations of equilibrium in terms of effective stresses are

$$\frac{\partial \sigma'_{xx}}{\partial x} + \frac{\partial \sigma'_{yx}}{\partial y} - (\gamma_s - \gamma_w) \cos \alpha + \frac{\partial p}{\partial x} = 0, \quad (4.32)$$

$$\frac{\partial \sigma'_{xy}}{\partial x} + \frac{\partial \sigma'_{yy}}{\partial y} + (\gamma_s - \gamma_w) \sin \alpha + \frac{\partial p}{\partial y} = 0. \quad (4.33)$$

Assuming that the slope is infinitely long, one may postulate that all derivatives in y -direction are zero, and therefore the equations reduce to

$$\frac{\partial \sigma'_{xx}}{\partial x} + (\gamma_s - \gamma_w) \cos \alpha + \frac{\partial p}{\partial x} = 0, \quad (4.34)$$

$$\frac{\partial \sigma'_{xy}}{\partial x} + (\gamma_s - \gamma_w) \sin \alpha = 0 \quad (4.35)$$

The stresses can now be obtained by integration,

$$\sigma'_{xx} + p = (\gamma_s - \gamma_w)x \cos \alpha, \quad (4.36)$$

$$\sigma'_{xy} = -(\gamma_s - \gamma_w)x \sin \alpha. \quad (4.37)$$

These stresses are the normal stress and shear stress acting on a plane parallel to the surface. When these stresses are denoted, for simplicity, by σ' and $-\tau$, respectively, one obtains

$$\sigma' + p = (\gamma_s - \gamma_w)x \cos \alpha, \quad (4.38)$$

$$\tau = (\gamma_s - \gamma_w)x \sin \alpha. \quad (4.39)$$

The appropriate form of the storage equation, in a moving coordinate system, is the one-dimensional form of equation (4.5),

$$\frac{k}{\gamma} \frac{\partial^2 p}{\partial \xi^2} = - \frac{v}{1-n} \frac{\partial n}{\partial \xi}. \quad (4.40)$$

It is now assumed that the failure of the slope consists of a continuous collapse of the loose structure of the sand, during which the density increases, while the resulting density is still sufficiently small for the sand to be flowing down the slope. To be more specific, it is assumed that there is a thin zone, of thickness d , at the slope surface, in which the porosity is lower than in the natural state, by an amount Δn . The decrease

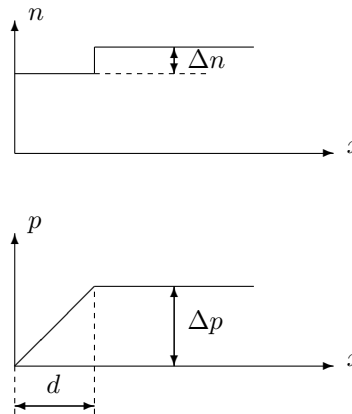

Figure 4.5: Schematization.

in volume occurring in the slip plane will result in an increase of the pore pressure. This excess pore pressure will be dissipated by a flow, and it seems natural to assume that this flow will be mainly towards the free draining surface of the soil, and to a much smaller extent into the medium. This leads to the mechanism illustrated in figure 4.5, in which there is an excess pore pressure in the medium, which is (practically)

constant, and which decreases linearly in the sliding zone. The differential equation (4.40) is satisfied in both zones ($x < d$ and $x > d$), and it will also be satisfied in the slip surface at depth d if

$$\frac{0 - (k/\gamma_w)(\Delta p/d)}{a} = -\frac{v}{1-n} \frac{\Delta n}{a}, \quad (4.41)$$

where a is the (infinitesimal) thickness of the slip surface. Solving for Δp gives

$$\Delta p = \gamma_w d \frac{v}{k} \frac{\Delta n}{1-n}. \quad (4.42)$$

Now suppose that at the slip surface the relationship between shear stress and effective normal stress is given by Coulomb's relation

$$\tau = \sigma' \tan \phi, \quad (4.43)$$

then one obtains, with (4.38) and (4.39),

$$(\gamma_s - \gamma_w)d \sin \alpha = (\gamma_s - \gamma_w)d \cos \alpha \tan \phi - \gamma_w d \frac{v}{k} \frac{\Delta n}{1-n} \tan \phi. \quad (4.44)$$

Hence

$$\frac{v}{k} = \frac{1-n}{\Delta n} \frac{\gamma_s - \gamma_w}{\gamma_w} \cos \alpha \left(1 - \frac{\tan \alpha}{\tan \phi}\right). \quad (4.45)$$

This expression shows that a positive velocity is possible if both $\tan \alpha < \tan \phi$ and $\Delta n > 0$. Thus a slope flatter than the natural slope may flow if the material is loose. An even more interesting case is that both $\Delta n < 0$ and $\tan \alpha > \tan \phi$. In such a case, of a very dense sand, a positive velocity is still possible, if the slope is steep enough. This case is further analyzed in the next section.

4.4 Vertical slope in dense sand

The approach of the previous section can be used to analyze the behaviour of a vertical slope in dense sand, see figure 4.6. It has been observed that such a vertical slope can indeed exist, but the sand at the surface is continuously failing, and thus the slope is moving into the sand. Again it is assumed that in the interior of the sand mass a homogeneous excess pore pressure is generated, in accordance with eq. (4.42),

$$\Delta p = \gamma_w d \frac{v}{k} \frac{\Delta n}{1-n}. \quad (4.46)$$

Because in this case Δn is negative (the sand in situ is denser than the flowing sand), the pore pressure is also negative. This negative pore pressure is actually maintaining the vertical slope, because it results in a positive effective stress, which increases the shear strength.

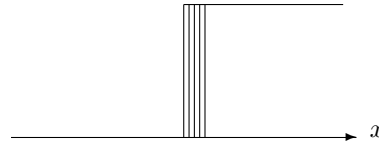

Figure 4.6: Vertical slope in dense sand.

The total stress and the shear stress follow from eqs. (4.38) and (4.39), with $\alpha = 0$,

$$\sigma = \sigma' + p = 0 \quad (4.47)$$

$$\tau = (\gamma_s - \gamma_w)d. \quad (4.48)$$

With Coulomb's relationship $\tau = \sigma' \tan \phi$, one now obtains

$$\frac{v}{k} = -\frac{1-n}{\Delta n} \frac{\gamma_n - \gamma_w}{\gamma_w} \frac{1}{\tan \phi}. \quad (4.49)$$

This is a positive velocity, because Δn is negative. Equation (45) is a special case of equation (4.49), with $\alpha \rightarrow \pi/2$.

The formula expresses that the velocity will be large if Δn is small, or when ϕ is small, or when k is large. All these results seem to be in agreement with experimental evidence, and with intuition.

Chapter 5

BEAMS ON ELASTIC FOUNDATION

In this chapter a numerical method for the solution of the problem of a beam on an elastic foundation is presented. Special care will be taken that the program can be used for beams consisting of sections of unequal length, as the program is to be used as a basis for programs for laterally loaded piles in a layered soils, and for a sheet pile wall program.

5.1 Beam theory

Consider a beam, of constant cross section, with its axis in the x -direction, see figure 5.1. The load on the beam is denoted by f , and the lateral

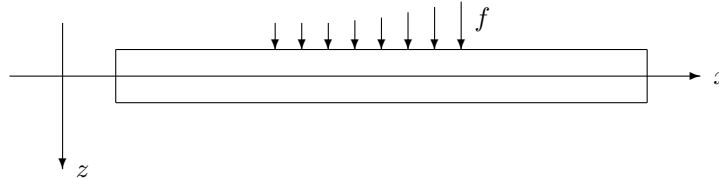

Figure 5.1: Problem definition.

displacement (in z -direction) is denoted by w . The basic equations from the classical beam theory are presented below.

Equilibrium in z -direction, that is the direction perpendicular to the axis of the beam, requires that

$$\frac{dQ}{dx} = -f, \quad (5.1)$$

where Q is the shear force. The sign convention is that a shear force is positive when the force on a surface with its normal in the positive x -direction is acting in the positive z -direction.

The second equation of equilibrium is the equation of equilibrium of moments, which requires that

$$\frac{dM}{dx} = Q, \quad (5.2)$$

where M is the bending moment. The sign convention is that a positive bending moment corresponds to a positive stress (tension) on the positive side of the axis of the beam.

The two equations of equilibrium can be combined to give

$$\frac{d^2 M}{dx^2} = -f. \quad (5.3)$$

This is the first basic equation of the theory of bending of beams.

The second basic equation can be derived from a consideration of the deformations of the beam. When it is assumed that plane cross sections of the beam remain plane after deformation (Bernoulli's hypothesis), and that the rotation dw/dx is small compared to 1, one obtains

$$EI \frac{d^2 w}{dx^2} = -M, \quad (5.4)$$

where EI is the flexural rigidity of the beam.

The two basic equations (5.3) and (5.4) can be combined to give

$$EI \frac{d^4 w}{dx^4} = f. \quad (5.5)$$

This is a fourth order differential equation for the lateral displacement, the basic equation of the classical theory of bending of beams.

Equation (5.5) can be solved analytically or numerically, subject to the appropriate boundary conditions.

5.2 Beam on elastic foundation

For a beam on an elastic foundation the lateral load consists of the external load, and a soil reaction.

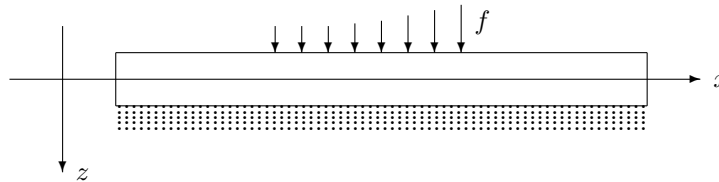

Figure 5.2: Beam on elastic foundation.

is assumed to be proportional to the lateral displacement. The basic differential now is

$$EI \frac{d^4 w}{dx^4} = f - kw, \quad (5.6)$$

where k is the subgrade modulus.

Various analytical solutions of this differential equation have been obtained, see Hetenyi [1946]. The homogeneous equation has solutions of the form

$$w = C_1 \exp\left(\frac{x}{\lambda}\right) \sin\left(\frac{x}{\lambda}\right) + C_2 \exp\left(\frac{x}{\lambda}\right) \cos\left(\frac{x}{\lambda}\right) + C_3 \exp\left(-\frac{x}{\lambda}\right) \sin\left(\frac{x}{\lambda}\right) + C_4 \exp\left(-\frac{x}{\lambda}\right) \cos\left(\frac{x}{\lambda}\right), \quad (5.7)$$

where $\lambda^4 = 4EI/k$. These solutions play an important role in the theory. It should be noted that a characteristic wave length of the solutions is $2\pi\lambda$. In a numerical solution it is advisable to take care that the interval length is small compared to this wave length.

In this chapter a numerical solution method will be presented. In solving the differential equation (5.6) by a numerical method it has to be noted that the bending moment M is obtained as the second derivative of the variable w , and the shear force Q as the third derivative. This means that, if the problem is solved as a problem in the variable w only, much accuracy will be lost when passing to the bending moment and the shear force. As these are important engineering quantities some other technique may be more appropriate. For this purpose it is convenient to return to the basic equations as they were derived in the previous section. Thus the basic equations are considered to be

$$\frac{d^2 M}{dx^2} = -f + kw. \quad (5.8)$$

and

$$EI \frac{d^2 w}{dx^2} = -M. \quad (5.9)$$

Although this system of two second order differential equations is of course completely equivalent to the single fourth order equation (5.6), in a numerical approach it may be more accurate to set up the method in terms of the two variables w and M . This will be elaborated in the next section.

5.3 Numerical model

In order to derive the equations describing the numerical model, special attention will be paid to the physical background of the equations. In this respect it is considered more important, for instance, that the equilibrium equations are satisfied as accurately as possible, rather than to use a strictly mathematical elaboration of the differential equations.

5.3.1 Basic equations

Let the beam be subdivided into a number of sections, say n sections. Now consider equilibrium of a single section, see figure 5.3. The element

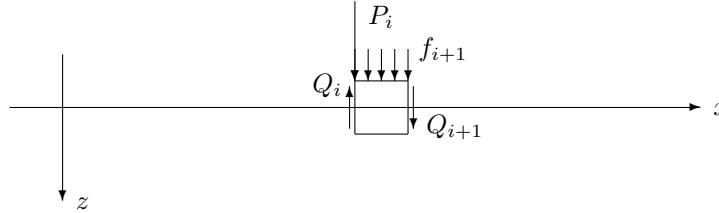

Figure 5.3: Element of a beam.

is supposed to be loaded by a distributed load f_{i+1} and a concentrated force P_i , which acts just to the right of the point x_i . The soil reaction is generated by the displacement, and will be of magnitude $-k_{i+1}\bar{w}_i$, where k_{i+1} is the subgrade constant in element $i + 1$, and \bar{w}_i is the average displacement of that element. The length of the element is supposed to be d_{i+1} .

Lateral equilibrium of the element requires that

$$Q_{i+1} - Q_i = -P_i - f_{i+1}d_{i+1} + \frac{1}{2}R_{i+1}(w_i + w_{i+1}), \quad (5.10)$$

where $R_{i+1} = k_{i+1}d_{i+1}$, and where it has been assumed that the average displacement of the element is the average of the displacements at the two ends. The subgrade modulus has been assumed to be constant over the element.

For element i the equilibrium equation can be obtained from eq. (5.10) by replacing i by $i - 1$. The result is

$$Q_i - Q_{i-1} = -P_{i-1} - f_i d_i + \frac{1}{2}R_i(w_{i-1} + w_i). \quad (5.11)$$

By adding these two equations one obtains

$$Q_{i+1} - Q_{i-1} = -P_i - P_{i-1} - f_{i+1}d_{i+1} - f_i d_i + \frac{1}{2}R_i w_{i-1} + \frac{1}{2}(R_i + R_{i+1})w_i + \frac{1}{2}R_{i+1}w_{i+1}. \quad (5.12)$$

This can, of course, also be considered as the equation of equilibrium of the two elements i and $i + 1$ together.

Equilibrium of moments of element $i + 1$ about its center requires that

$$M_{i+1} - M_i = \frac{1}{2}(Q_{i+1} + Q_i)d_{i+1} - \frac{1}{2}P_i d_{i+1}. \quad (5.13)$$

Replacing i by $i - 1$ gives the equation of moment equilibrium for element i ,

$$M_i - M_{i-1} = \frac{1}{2}(Q_i + Q_{i-1})d_i - \frac{1}{2}P_{i-1}d_i. \quad (5.14)$$

Elimination of Q_i from (5.13) and (5.14) gives

$$\frac{1}{d_{i+1}}M_{i+1} - \left(\frac{1}{d_{i+1}} + \frac{1}{d_i}\right)M_i + \frac{1}{d_i}M_{i-1} = \frac{1}{2}(Q_{i+1} - Q_{i-1} - P_i + P_{i-1}), \quad (5.15)$$

or, with (5.12),

$$\frac{1}{d_{i+1}}M_{i+1} - \left(\frac{1}{d_{i+1}} + \frac{1}{d_i}\right)M_i + \frac{1}{d_i}M_{i-1} - \frac{1}{4}R_{i+1}w_{i+1} - \frac{1}{4}(R_i + R_{i+1})w_i - \frac{1}{4}R_iw_{i-1} = -\frac{1}{2}(d_i f_i + d_{i+1} f_{i+1}) - P_i. \quad (5.16)$$

This is the first basic equation of the numerical model. It is the numerical equivalent of eq. (5.8). All terms can easily be recognized, but the precise value of all the coefficients is not immediately clear. For this purpose the complete derivation presented above has to be processed.

The second basic equation must be the numerical equivalent of equation (5.9). This can be obtained as follows. Consider the two elements to the left and to the right of point x_i . In the element to the left (element i) we have

$$x < x_i : EI \frac{d^2 w}{dx^2} = -\frac{1}{2}(M_{i-1} + M_i), \quad (5.17)$$

where it has been assumed that the bending moment in this element is the average of the values at the two ends. On the other hand we have in element $i + 1$,

$$x > x_i : EI \frac{d^2 w}{dx^2} = -\frac{1}{2}(M_i + M_{i+1}). \quad (5.18)$$

These two equations can be integrated, assuming that the right hand side is constant, to give

$$x < x_i : EIw = -\frac{1}{4}(M_{i-1} + M_i)(x - x_i)^2 + A(x - x_i) + EIw_i, \quad (5.19)$$

and

$$x > x_i : EIw = -\frac{1}{4}(M_i + M_{i+1})(x - x_i)^2 + A(x - x_i) + EIw_i, \quad (5.20)$$

where the integration constants have been chosen such that for $x = x_i$ the displacement is always w_i and the slope is continuous at that point (namely A/EI).

Substituting $x = x_{i-1}$ in eq. (5.19) and $x = x_{i+1}$ into eq. (5.20) gives two expressions for A . After elimination of A one obtains, finally,

$$\frac{EI}{d_{i+1}}w_{i+1} - \left(\frac{EI}{d_{i+1}} + \frac{EI}{d_i}\right)w_i + \frac{EI}{d_i}w_{i-1} + \frac{1}{4}d_{i+1}M_{i+1} + \frac{1}{4}(d_{i+1} + d_i)M_i + \frac{1}{4}d_iM_{i-1} = 0. \quad (5.21)$$

This is the second basic equation of the numerical model, the numerical equivalent of the differential equation (5.9). Its form is very similar to the first basic equation, eq. (5.16). When all the elements have the same size d , and all the coefficients in the second part of the equation are lumped together, a simplified form of this equation is

$$\frac{EI}{d^2}w_{i+1} - \frac{2EI}{d^2}w_i + \frac{EI}{d^2}w_{i-1} + M_i = 0. \quad (5.22)$$

This is a well known approximation of eq. (5.4) by central finite differences. The refinements in eq. (5.21) are due to the use of unequal intervals and a more refined approximation of the bending moment.

5.3.2 Boundary conditions

The boundary conditions must also be approximated numerically. This needs some careful consideration, as it is most convenient if the two boundary conditions at either end of the beam can be expressed in terms of w and M in these points. This is very simple in the case of a hinged support (then $w = 0$ and $M = 0$). For other boundary conditions, such as a clamped boundary or a free boundary, the boundary conditions must be somewhat manipulated in order for them to be expressed in the two basic variables. If the left end of the beam is free the boundary conditions are

$$M_0 = -M_l, \quad (5.23)$$

$$Q_0 = -F_l, \quad (5.24)$$

where M_l is a given external moment, and F_l is a given force. The first boundary condition can immediately be incorporated into the system of equations, but the second condition needs some special attention, because the shear force has been eliminated from the system of equations. In this case equation (5.10) gives, with $i = 0$,

$$Q_1 = -F_l - f_1d_1 + \frac{1}{2}R_1(w_0 + w_1). \quad (5.25)$$

This equation expresses lateral equilibrium of the first element. On the other hand, the equation of equilibrium of moments of the first element gives, with (5.13) for $i = 0$,

$$M_1 - M_0 = \frac{1}{2}(Q_1 - F_l)d_1. \quad (5.26)$$

Elimination of Q_1 from these two equations gives

$$\frac{1}{2}R_1w_0 + \frac{1}{2}R_1w_1 + \frac{2}{d_1}M_0 - \frac{2}{d_1}M_1 = f_1d_1 + 2F_l. \quad (5.27)$$

In this form the boundary condition (5.24) can be incorporated into the system of algebraic equations. It gives a relation between the bending moments and the displacements in the first two points.

If the left end of the beam is fully clamped the boundary conditions are

$$w_0 = 0, \quad (5.28)$$

$$x = 0 : \frac{\partial w}{\partial x} = 0. \quad (5.29)$$

The first condition can immediately be incorporated into the system of equations. The second condition can best be taken into account by considering equation (5.22) for $i = 0$,

$$\frac{EI}{d^2}w_1 - \frac{2EI}{d^2}w_0 + \frac{EI}{d^2}w_{-1} + M_0 = 0. \quad (5.30)$$

The boundary condition (5.29) can be assumed to be satisfied by the symmetry condition $w_{-1} = w_1$, and thus, because $w_0 = 0$,

$$\frac{2EI}{d^2}w_1 + M_0 = 0. \quad (5.31)$$

The distance d in this equation must be interpreted as the length of the first element. The condition (5.31) can easily be incorporated into the system of algebraic equations.

The boundary conditions at the right end of the beam can be taken into account in a similar way as those at the left end.

5.3.3 Computer program

An elementary computer program, in Turbo Pascal, is reproduced below, as the program WINKLER. The program applies to a beam consisting of a number of sections. Each section can have a different load, and have a different subgrade constant. In the points separating two sections concentrated loads can be applied. The two boundaries can be clamped, hinged or free. Output is given in the form of a list on the screen.

```

program winkler;
uses crt;
const
  maxsec=20;nel=100;wid=4;
var
  sec,jl,jr:integer;
  ei,tl,tr:real;
  l,k,q:array[1..maxsec] of real;
  xx,ff,mm:array[0..maxsec] of real;
  x,d,f,r,p,m,u:array[0..nel] of real;
  a:array[0..nel,1..wid,1..2,1..2] of real;

```

```

kk:array[0..nel,1..wid] of integer;
g:array[1..2,1..2] of real;
procedure title;
begin
  clrscr;gotoxy(36,1);textbackground(7);textcolor(0);
  write(' WINKLER ');
  textbackground(0);textcolor(7);writeln;
end;
procedure next;
var
  a:char;
begin
  gotoxy(25,25);textbackground(7);textcolor(0);
  write(' Touch any key to continue ');write(chr(8));
  a:=readkey;textbackground(0);textcolor(7)
end;
procedure input;
var
  i,j,m,n:integer;
  w,a:real;
begin
  title;writeln;
  write('This is a program for the analysis of the deflections');
  writeln(' and bending moments');
  write('in a beam of uniform cross section, supported by an');
  writeln(' elastic foundation. ');
  write('The beam consists of a number of sections, in each of');
  writeln(' which the subgrade');
  writeln('coefficient and the distributed load are constant. ');
  writeln('Concentrated forces may act in the joints. ');writeln;
  write('Number of sections ..... ');readln(sec);writeln;
  if sec<1 then sec:=1;if sec>maxsec then sec:=maxsec;
  write('Flexural rigidity EI (kNm2) ... ');readln(ei);writeln;
  ff[0]:=0.0;xx[0]:=0.0;tl:=0.0;tr:=0.0;
  for i:=1 to sec do
    begin
      title;writeln;writeln('Section ',i);writeln;
      write(' Length (m) ..... ');readln(l[i]);writeln;
      write(' Subgrade constant (kN/m2) ... ');readln(k[i]);writeln;
      write(' Distributed load (kN/m) ..... ');readln(q[i]);writeln;
      ff[i]:=0.0;xx[i]:=xx[i-1]+l[i];
    end;
  for i:=1 to sec-1 do

```

```
begin
  title;writeln;
  writeln('Joint between sections ',i,' and ',i+1);writeln;
  write(' Force (kN) ..... ');
  readln(ff[i]);writeln;
end;
title;writeln;
writeln('Boundary condition at left end');writeln;
writeln(' 1 : Fully clamped support');writeln;
writeln(' 2 : Hinged support');writeln;
writeln(' 3 : Free end');writeln;
write('Enter option number : ');readln(jl);writeln;
if jl<1 then jl:=1;if jl>3 then jl:=3;
if jl>2 then
  begin
    write(' Force (kN) ..... ');
    readln(ff[0]);writeln;
  end;
if jl>1 then
  begin
    write(' Moment (kNm) ..... ');
    readln(tl);writeln;
  end;
title;writeln;
writeln('Boundary condition at right end');writeln;
writeln(' 1 : Fully clamped support');writeln;
writeln(' 2 : Hinged support');writeln;
writeln(' 3 : Free end');writeln;
write('Enter option number : ');readln(jr);writeln;
if jr<1 then jr:=1;if jr>3 then jr:=3;
if jr>2 then
  begin
    write(' Force (kN) ..... ');
    readln(ff[sec]);writeln;
  end;
if jr>1 then
  begin
    write(' Moment (kNm) ..... ');
    readln(tr);writeln;
  end;
x[0]:=0.0;p[0]:=ff[0];j:=0;for i:=1 to sec do
  begin
    w:=xx[i]-xx[i-1];n:=round((w/xx[sec])*nel);if n<1 then n:=1;
```

```

if j+n>nel then n:=nel-j;a:=w/n;
for m:=j+1 to j+n do
begin
x[m]:=x[m-1]+a;d[m]:=a;r[m]:=k[i]*a;
f[m]:=q[i]*a;p[m]:=0.0;
end;
j:=m;p[j]:=ff[i];
end;
end;
procedure matrix;
var
i,j,h,k,l:integer;a1,a2,b1,b2,c1:real;
begin
h:=wid;
for i:=0 to nel do for j:=1 to h do
begin
kk[i,j]:=0;
for k:=1 to 2 do for l:=1 to 2 do a[i,j,k,l]:=0;
end;
for i:=1 to nel-1 do
begin
kk[i,1]:=i;kk[i,2]:=i-1;kk[i,3]:=i+1;kk[i,h]:=3;
end;
kk[0,1]:=0;kk[0,2]:=1;kk[0,h]:=2;
kk[nel,1]:=nel;kk[nel,2]:=nel-1;kk[nel,h]:=2;
for i:=1 to nel-1 do
begin
a1:=1.0/d[i+1];a2:=1.0/d[i];
a[i,1,1,1]:=-a1-a2;a[i,2,1,1]:=a2;a[i,3,1,1]:=a1;
a[i,1,1,2]:=-(r[i]+r[i+1])/4.0;a[i,2,1,2]:=-r[i]/4.0;
a[i,3,1,2]:=-r[i+1]/4.0;
a[i,h,1,1]:=-(f[i]+f[i+1])/2.0-p[i];
a[i,1,2,2]:=-a1-a2;a[i,2,2,2]:=a2;a[i,3,2,2]:=a1;
a[i,1,2,1]:=(d[i]+d[i+1])/(4.0*ei);
a[i,2,2,1]:=d[i]/(4.0*ei);a[i,3,2,1]:=d[i+1]/(4.0*ei);
end;
a[0,1,1,1]:=1.0;a[0,1,2,2]:=1.0;
if j1=1 then a[0,2,1,2]:=2.0*ei/(d[1]*d[1]);
if j1=2 then a[0,4,1,1]:=-t1;
if j1=3 then
begin
a[0,4,1,1]:=-t1;a[0,1,2,2]:=0.5*r[1];
a[0,2,2,2]:=0.5*r[1];a[0,1,2,1]:=2.0/d[1];

```



```

    a[0,2,2,1]:=-2.0/d[1];a[0,4,2,2]:=f[1]+2.0*ff[0];
end;
a[nel,1,1,1]:=1.0;a[nel,1,2,2]:=1.0;
if jr=1 then a[nel,2,1,2]:=2.0*ei/(d[nel]*d[nel]);
if jr=2 then a[nel,4,1,1]:=tr;
if jr=3 then
begin
a[nel,4,1,1]:=tr;a[nel,1,2,2]:=0.5*r[nel];
a[nel,2,2,2]:=0.5*r[nel];a[nel,1,2,1]:=2.0/d[nel];
a[nel,2,2,1]:=-2.0/d[nel];a[nel,4,2,2]:=f[nel]+2.0*ff[sec];
end;
end;
procedure solve;
var
i,j,h,k,l,ii,ij,ik,jj,jk,jl,jv,kc,kv,lv:integer;
cc,aa:real;
begin
h:=wid;
for i:=nel downto 0 do
begin
kc:=kk[i,h];for kv:=1 to 2 do
begin
if a[i,1,kv,kv]=0.0 then
begin
writeln('Error : no equilibrium possible');halt;
end;
cc:=1.0/a[i,1,kv,kv];
for ii:=1 to kc do for lv:=1 to 2 do
begin
a[i,ii,kv,lv]:=cc*a[i,ii,kv,lv];
end;
a[i,h,kv,kv]:=cc*a[i,h,kv,kv];
for lv:=1 to 2 do if (lv<>kv) then
begin
cc:=a[i,1,lv,kv];
for ii:=1 to kc do for ij:=1 to 2 do
begin
a[i,ii,lv,ij]:=a[i,ii,lv,ij]-cc*a[i,ii,kv,ij];
end;
a[i,h,lv,lv]:=a[i,h,lv,lv]-cc*a[i,h,kv,kv];
end;
end;
end;
if kc>1 then

```

```

begin
for j:=2 to kc do
begin
jj:=kk[i,j];l:=kk[jj,h];jk:=1;
for jl:=2 to 1 do begin if kk[jj,jl]=i then jk:=jl;end;
for kv:=1 to 2 do for lv:=1 to 2 do g[kv,lv]:=a[jj,jk,kv,lv];
kk[jj,jk]:=kk[jj,1];kk[jj,l]:=0;
for kv:=1 to 2 do for lv:=1 to 2 do
begin
a[jj,jk,kv,lv]:=a[jj,l,kv,lv];a[jj,l,kv,lv]:=0;
a[jj,h,lv,lv]:=a[jj,h,lv,lv]-g[lv,kv]*a[i,h,kv,kv];
end;
l:=l-1;kk[jj,h]:=1;
for ii:=2 to kc do
begin
ij:=0;
for ik:=1 to 1 do
begin
if kk[jj,ik]=kk[i,ii] then ij:=ik;
end;
if ij=0 then
begin
l:=l+1;ij:=1;kk[jj,h]:=1;kk[jj,ij]:=kk[i,ii];
end;
for kv:=1 to 2 do for lv:=1 to 2 do for jv:=1 to 2 do
a[jj,ij,kv,lv]:=a[jj,ij,kv,lv]-g[kv,jv]*a[i,ii,jv,lv];
end;
end;
end;
end;
for j:=0 to nel do
begin
l:=kk[j,h];if l>1 then
begin
for k:=2 to 1 do
begin
jj:=kk[j,k];
for kv:=1 to 2 do for lv:=1 to 2 do
a[j,h,kv,kv]:=a[j,h,kv,kv]-a[j,k,kv,lv]*a[jj,h,lv,lv];
end;
end;
end;
end;
for i:=0 to nel do

```

```

begin
  m[i]:=a[i,h,1,1];u[i]:=a[i,h,2,2];
end;
end;
procedure output;
var
  i,j,k:integer;
begin
  k:=0;title;
  writeln('      i      x      w      M');writeln;
  for i:=0 to nel do
  begin
    if k<=20 then
      begin
        writeln(i:6,x[i]:13:6,u[i]:13:6,m[i]:13:6);k:=k+1;
      end
    else if i<nel then
      begin
        next;k:=0;i:=i-2;title;
        writeln('      i      x      w      M');writeln;
      end;
    end;
  next;
end;
begin
  input;
  matrix;
  solve;
  output;
  title;
end.

```

Program WINKLER.

The program runs interactively, and will present information about its operation and input data automatically. More advanced features, such as graphical output facilities, may be added by the user.

The numerical model for a beam on elastic foundation can be used as the basis for a model in which the soil response is non-linear. This is especially useful for the analysis of sheet pile walls, or laterally loaded piles. In such cases the soil pressure is restricted between certain limits, the active and passive soil pressure, and an elasto-plastic model may be used to model the soil response. This is elaborated in chapter 8.

Problems

- 5.1 Verify that the program WINKLER gives the correct results for some elementary problems of the theory of bending of beams, such as a beam on two hinged supports carrying a point load in the center, or carrying a uniform load.
- 5.2 Verify also that the program WINKLER gives the correct results for a beam with two free ends on a homogeneous foundation, carrying a uniform load. In this case the bending moments must be zero, and the displacement must be constant, also if the beam is considered to consist of a number of sections of unequal length.
- 5.3 Compare the results obtained by the program WINKLER with analytical solutions for the case of a long beam on a homogeneous elastic foundation, with a force or a moment at its end.
- 5.4 Modify the program WINKLER so that it shows the deflection curve and the bending moment in the form of a graph on the screen.

Chapter 6

AXIALLY LOADED PILES

The response of a foundation pile to an axial load applied at its top is in general strongly non-linear, and may involve large irreversible deformations. In this chapter this will be discussed, and solution techniques will be developed. Some simple analytic solutions will be presented first. In a later section a numerical model will be developed for problems involving non-linear material behaviour.

Throughout this chapter the behaviour of the soil surrounding the pile will be characterized by the response of a non-linear spring. The response of this spring is completely determined by the local displacement of the pile. This means that all vertical stress transfer in the soil is disregarded. Models to take this effect into account have been developed (Poulos, 1986) for elastic soils.

6.1 Pile in linear material

Consider a pile of constant cross sectional area A , consisting of a linear elastic material, with modulus of elasticity E . The circumference of the pile is denoted by O . The normal force N in the pile can be related to the friction along the circumference by the equation of equilibrium

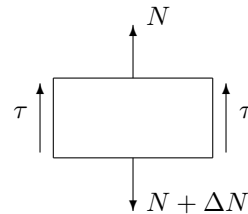

Figure 6.1: Element of axially loaded pile.

$$\frac{dN}{dz} - \tau O = 0. \tag{6.1}$$

The normal force N is related to the stress by

$$N = \sigma A,$$

and the stress is related to the strain by Hooke's law for the pile material

$$\sigma = E\varepsilon.$$

Finally, the strain is related to the vertical displacement w by the relation

$$\varepsilon = dw/dz.$$

Thus the normal force N is related to the vertical displacement w by the relation

$$N = EA \frac{dw}{dz}. \quad (6.2)$$

Substitution of eq. (6.2) into eq. (6.1) gives

$$EA \frac{d^2w}{dz^2} - \tau O = 0. \quad (6.3)$$

The further analysis depends upon the relation between the shear stress τ and the displacement w .

In this section it will be assumed that the shear stress τ is proportional to the vertical displacement w ,

$$\tau = cw, \quad (6.4)$$

where c has the character of a subgrade modulus.

Substitution of eq. (6.4) in (6.3) gives

$$EA \frac{d^2w}{dz^2} - cOw = 0. \quad (6.5)$$

This is the basic differential equation for an axially loaded pile supported by continuous linear springs.

When all the physical and geometrical parameters are constant the general solution of the differential equation (6.5) is

$$w = C_1 \exp(z/h) + C_2 \exp(-z/h), \quad (6.6)$$

where h is a characteristic length, defined by

$$h = \sqrt{EA/cO}, \quad (6.7)$$

and where C_1 and C_2 are integration constants, to be determined from the boundary conditions. For a pile of length l , loaded at its top these boundary conditions are

$$z = 0 : \quad N = -P, \quad (6.8)$$

and

$$z = l : \quad N = 0, \quad (6.9)$$

when it is assumed that there is no point resistance.

Using the boundary conditions the constants C_1 and C_2 can be determined. The final expression for the vertical displacement then is

$$w = \frac{Ph}{EA} \frac{\cosh[(l-z)/h]}{\sinh(l/h)}. \quad (6.10)$$

The corresponding formula for the normal force in the pile is

$$N = -P \frac{\sinh[(l-z)/h]}{\sinh(l/h)}. \quad (6.11)$$

It can easily be seen that this solution satisfies the two boundary conditions. The solution is shown graphically in figure 6.2.

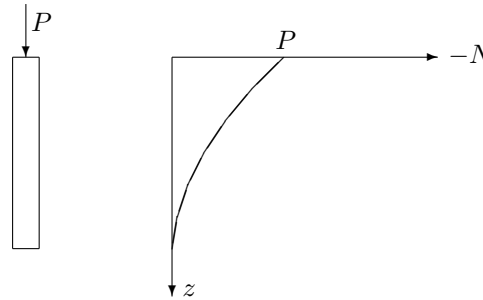

Figure 6.2: Normal force in pile.

The depth of influence of the load at the top is determined by the value of the parameter h . This parameter also determines how long a pile must be to be considered infinitely long. Therefore it is interesting to estimate the value of h . This will be done for an important particular case, namely a tubular steel pile. Let the diameter of the pile be D and the wall thickness d . Then $O = \pi D$ and $A = \pi Dd$. Furthermore the subgrade constant can be estimated to be related to the elasticity of the soil (E_s) by a relation of the type $c = E_s/D$. Thus eq. (6.7) becomes

$$h = \sqrt{EDd/E_s}. \quad (6.12)$$

The ratio of the elastic moduli of steel and soil is of the order of magnitude 1000 (or perhaps even more), the radius of the pile may be 1 m, and the wall thickness may be 0.050 m. In that case one obtains $h \approx 7$ m, indicating that the order of magnitude of this parameter is 10 m, or perhaps more. Thus, if the mechanism of load transfer considered here is applicable (and it will appear that this is certainly not always the case), a pile longer than say 10 m or 20 m can be considered as infinitely long.

If $l \rightarrow \infty$ the solution (6.10) reduces to

$$w = \frac{Ph}{EA} \exp(-z/h), \quad (6.13)$$

and the formula for the normal force in the pile becomes

$$N = -P \exp(-z/h). \quad (6.14)$$

It may be noted that in all these cases the shear stress is proportional to the displacement, see eq. (6.4). Thus the maximum shear stress occurs at the top of the pile, and the shear stress decreases exponentially with depth. Although this seems perfectly reasonable under the assumptions made, it may be in conflict with the shear strength properties of the soil, as will be elaborated in the next sections.

6.2 Pile in cohesive material

For a pile in a cohesive material, such as clay, the shear stress along the shaft of the pile can not be larger than some limiting value, see figure 6.3. In the plastic branch the shear stress remains constant, even if the displacement increases. The maximum shear stress is denoted by τ_0 . Its

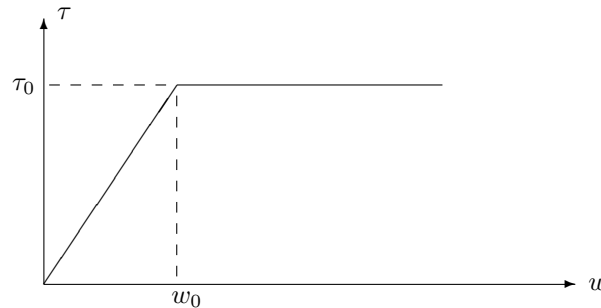

Figure 6.3: Cohesive material.

magnitude will be close to the undrained shear strength s_u of the clay, but is not necessarily the same, because it may be influenced by the

roughness of the pile wall, and by the behaviour of the clay (e.g. dilatant properties). It has also been observed that the maximum shear stress is larger when the pile is in compression than when it is in tension. This may be due to the lateral deformation of the pile.

The elastic branch can be characterized by the subgrade modulus, see eq. (6.4). Another way to characterize the elastic branch is through the maximum shear stress τ_0 and the *quake* w_0 , that is the displacement necessary to generate the maximum shear stress. Actually, this parameter is often considered more convenient, and easier to estimate. The relation with the subgrade modulus is

$$c = \frac{\tau_0}{w_0}. \quad (6.15)$$

The quake may be estimated by noting that the elastic shear deformation of the soil is limited to say about 1 % or 2 %, and that the deformation will occur around the pile, in a zone which can be expected to be about as large as the radius of the pile, see figure 6.4. This means that the

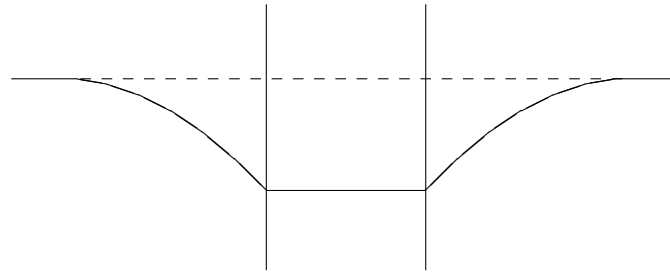

Figure 6.4: Deformation of the soil around the pile.

order of magnitude of the quake will be about 1 % of the pile diameter,

$$w_0 \approx 0.01 D. \quad (6.16)$$

It may be noted that this means that the subgrade modulus is about $c = 100 s_u/D$. Comparing this to the correlation $c = E_s/D$ shows that these correlations are in agreement if the modulus of elasticity of a clayey soil is about 100 times the undrained shear strength. This is a relation that is indeed often found in engineering practice.

It may also be noted that in thick deposits of natural clay the shear strength often increases with depth. Keeping the quake constant in such a material automatically ensures that the stiffness in the elastic branch also increases with depth, which is in agreement with experimental evidence. All these considerations support the preference for the parameter w_0 , the quake, to characterize the elastic branch of the response.

Solution for an infinitely long pile

For an axially loaded pile in a homogeneous cohesive material the distribution of shear stresses along the pile shaft is shown in figure 6.5, provided that the load P is large enough to produce sliding of the pile along the soil at the top part. If it is assumed that the depth over which

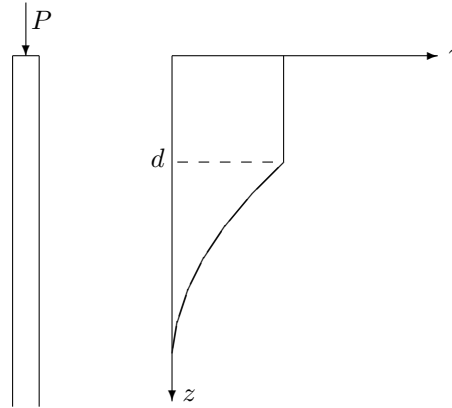

Figure 6.5: Shear stress along pile in clay.

plastic deformations occur is d , the problem consists of two parts, one ($d < z < l$) in which the shear stress is proportional to the displacement, and another one ($0 < z < d$) in which the shear stress is constant. If it is assumed that the pile is long enough to be considered as infinitely long, the solution in the elastic part is similar to the solution (6.13) for a pile in a completely elastic material, except that the top is now at the level $z = d$,

$$w = w_0 \exp[-(z - d)/h]. \quad (6.17)$$

The normal force in this part is

$$N = -\frac{EAw_0}{h} \exp[-(z - d)/h], \quad (6.18)$$

which means that the normal force at the top of the elastic part is

$$N_d = -\frac{EAw_0}{h}. \quad (6.19)$$

In the plastic part the differential equation is, with (6.3),

$$EA \frac{d^2 w}{dz^2} = \tau_0 O. \quad (6.20)$$

The solution of this problem will not be given in detail here. It is a relatively simple differential equation, and the boundary conditions follow immediately from the given load at the top, and the known force and displacement at the bottom of the plastic region.

The final solution of the problem in the plastic part is

$$w = w_0 \left(1 + \frac{d-z}{h}\right) + \frac{\tau_0 O}{2EA} (d-z)^2. \quad (6.21)$$

The maximum displacement w_t occurs at the top of the pile, of course. Its value is

$$w_t = w_0 \left(1 + \frac{d}{h}\right) + \frac{\tau_0 O d^2}{2EA}. \quad (6.22)$$

The normal force in the plastic region is found to be

$$N = -\frac{EA w_0}{h} - \tau_0 O (d-z). \quad (6.23)$$

The normal force at the top is

$$P = \frac{EA w_0}{h} + \tau_0 O d. \quad (6.24)$$

By noting that

$$h = \sqrt{EA/cO} = \sqrt{EA w_0 / \tau_0 O}, \quad (6.25)$$

the relation between the force at the top (P) and the displacement at the top (w_t) can be written as

$$w_t = w_0 \left(1 + \frac{d}{h} + \frac{d^2}{2h^2}\right), \quad (6.26)$$

$$\frac{Ph}{EA} = w_0 \left(1 + \frac{d}{h}\right). \quad (6.27)$$

This is a parameter representation of the force-displacement relation of the pile. After elimination of the parameter d/h one obtains

$$\frac{w_t}{w_0} = \frac{1}{2} \left[1 + \left(\frac{Ph}{EA w_0}\right)^2\right]. \quad (6.28)$$

This solution applies only if $d > 0$, otherwise the relation between w_t and P is linear, passing through the origin and the point $w = w_0$, $P = EA w_0 / h$. The relation between P and w_t is shown in figure 6.6. After a first linear branch the displacement increases more rapidly with the

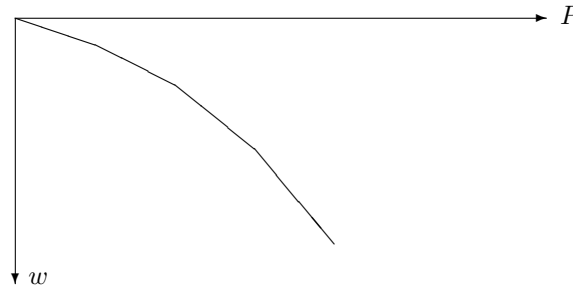

Figure 6.6: Load-displacement curve for pile in clay.

pile load, as an ever increasing part at the top of the pile becomes plastic. There is no limit load, as the pile is infinitely long.

It should be noted that the analysis presented in this section assumes that the shear stress along the pile shaft is zero when the displacement is zero. This will be the case if the pile is loaded for the first time, and if there are no initial normal forces in the pile. After several times of loading to a level at which plastic deformations are produced, an equilibrium system of stresses may remain in the pile after unloading. The analysis then is much more complicated, and is best performed numerically. Such a numerical approach will be presented later.

Solution for a pile of finite length

For a pile of finite length in a homogeneous cohesive material, loaded by an axial force, it can be assumed that the plastic deformations will start in a zone of length d near the top of the pile. The analysis is restricted to monotonic loading of an initially unstressed pile. It should be noted that after once loading the pile beyond the initiation of plastic deformations and subsequent unloading, permanent displacements of the pile top are generated and a system of stresses remains in the pile after unloading. The actual stresses and deformations then depend upon the loading history of the pile. This is excluded here by assuming that the pile is free of stress before the loading.

In the elastic zone, for $d < z < l$, the differential equation is (6.5),

$$EA \frac{d^2 w}{dz^2} - cOw = 0. \quad (6.29)$$

with the solution

$$w = C_1 \exp(z/h) + C_2 \exp(-z/h), \quad (6.30)$$

where $h = \sqrt{EA/cO}$. Using the condition that the normal force is zero at the bottom end of the pile, i.e. for $z = l$, it follows that the solution can be written as

$$w = 2C_1 \exp(l/h) \cosh[(l - z)/h]. \quad (6.31)$$

At the depth $z = d$ this displacement must be equal to the value of the quake, w_0 , i.e. the displacement necessary to reach plasticity. This determines the constant C_1 , and the solution can be written as

$$d < z < l : w = w_0 \frac{\cosh[(l - z)/h]}{\cosh[(l - d)/h]}. \quad (6.32)$$

The normal stress in the elastic part of the pile is

$$d < z < l : N = EA \frac{dw}{dz} = -EA \frac{w_0}{h} \frac{\sinh[(l - z)/h]}{\cosh[(l - d)/h]}. \quad (6.33)$$

It can easily be verified that the solution in the elastic part of the pile satisfies the conditions that for $z = l$ the normal force is zero, and that for $z = d$ the displacement is equal to w_0 .

In the plastic part of the pile the differential equation is equation (6.20), which can also be written as

$$0 < z < d : \frac{d^2 w}{dz^2} = \frac{w_0}{h^2}. \quad (6.34)$$

The solution of this linear differential equation is

$$0 < z < d : w = \frac{1}{2} w_0 \frac{z^2}{h^2} + D_1 z + D_2, \quad (6.35)$$

where D_1 and D_2 are constants, to be determined from the boundary conditions. These constants can best be determined from the continuity conditions at the level $z = d$, where the displacement w and the normal force N must be continuous. This gives

$$D_1 = -\frac{w_0 d}{h^2} - \frac{w_0}{h} \tanh[(l - d)/h], \quad (6.36)$$

$$D_2 = w_0 + \frac{1}{2} w_0 \frac{d^2}{h^2} + w_0 \frac{d}{h} \tanh[(l - d)/h]. \quad (6.37)$$

The displacement w_t of the top of the pile is found to be

$$\frac{w_t}{w_0} = 1 + \frac{1}{2} \frac{d^2}{h^2} + \frac{d}{h} \tanh[(l - d)/h]. \quad (6.38)$$

If the normal force at the top of the pile is denoted by $-P$, the minus sign denoting that P is a compressive force, it is found that

$$\frac{P}{P_0} = \frac{d/h + \tanh[(l-d)/h]}{\tanh(l/h)}, \quad (6.39)$$

where P_0 is the normal force at the moment when the displacement of the top of the pile reaches the value of the quake, i.e.

$$P_0 = EA \frac{w_0}{h} \tanh(l/h). \quad (6.40)$$

Equations (6.38) and (6.39) form a parameter representation of the relation between the force P at the top of the pile and the displacement w_t of the top of the pile. They apply only if the force P is sufficiently large for plastic deformations to develop. In the elastic range the response is a linear relation, through the point $w = w_0$ for $P = P_0$.

The maximum possible value of the length of the plastic zone is $d = l$. Then equation (6.39) gives

$$\frac{P_{\max}}{P_0} = \frac{l/h}{\tanh(l/h)}. \quad (6.41)$$

With (6.40) this gives

$$P_{\max} = EA l \frac{w_0}{h^2}. \quad (6.42)$$

Using the definition of h and the relation $w_0 = c\tau_0$ it finally follows that

$$P_{\max} = Ol\tau_0, \quad (6.43)$$

which simply states that the maximum possible force is the maximum shear stress multiplied by the area of the pile. That is a trivial result, but it is encouraging that the general solution indeed leads to this maximum value.

As an example figure 6.7 shows the load displacement curve for the case that $l/h = 4.0$. The figure has been constructed by letting d/l vary from 0.00 to 0.99 and then calculating the force from eq. (6.39) and the displacement from eq. (6.38).

It can easily be verified that the solution of this section, as expressed by eqs. (6.38) and (6.39), reduces to the solution given in the previous section for a pile of infinite length, see eqs. (6.26) and (6.27), when the pile length l tends towards infinity.

6.3 Pile in frictional material

For an axially loaded pile in a homogeneous frictional material such as sand, it can be expected that the shear stress can not be larger than the maximum value as given by Coulomb's relation

$$\tau_f = \sigma'_h \tan \delta, \quad (6.44)$$

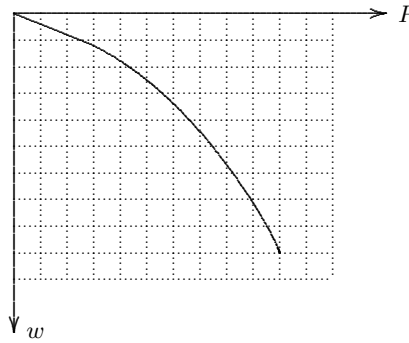

Figure 6.7: Load-displacement curve.

where σ'_h is the effective horizontal normal stress, and δ is the friction angle between pile and soil. It has been assumed, for reasons of simplicity, that the soil is cohesionless. The expected distribution of shear stresses along the pile shaft is shown schematically in figure 6.8. This figure is based upon the notion that the normal stresses in a soil increase linearly with depth. Using Coulomb's relation (6.44) it then follows that this is also the case for the maximum shear stresses.

In the most simple case, of a homogeneous soil under water, one may write for the vertical effective stresses in the soil

$$\sigma'_v = \gamma' z, \quad (6.45)$$

where γ' is the volumetric weight of the soil under water, i.e.,

$$\gamma' = \gamma - \gamma_w, \quad (6.46)$$

where γ is the volumetric weight of the soil as a whole, and γ_w is the volumetric weight of water.

The horizontal effective stresses are usually considered to be a certain fraction of the vertical effective stresses,

$$\sigma'_h = K_0 \sigma'_v = K_0 \gamma' z, \quad (6.47)$$

where K_0 , the coefficient of lateral earth pressure at rest, is supposed to be a given constant. Usually K_0 is somewhat smaller than 1, say $K_0 = 0.5$ or $K_0 = 0.8$, depending upon the soil properties and upon the geological and geotechnical history.

With (6.47) the maximum shear stress, see (6.44), is found to be

$$\tau_f = K_0 \tan \delta \sigma'_v = K_0 \tan \delta \gamma' z. \quad (6.48)$$

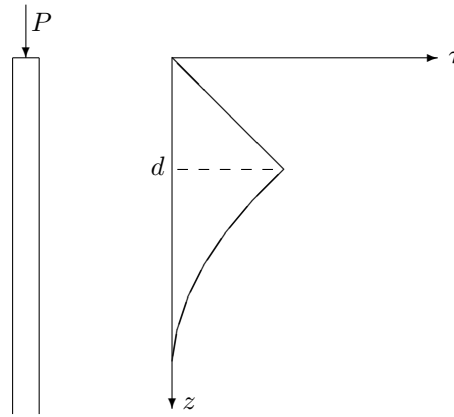

Figure 6.8: Shear stress along pile in sand.

The order of magnitude of the product coefficient $K_0 \tan \delta$ will be in the range from 0.2 to 0.4.

Again the transition from the elastic to the plastic range is characterized by the quake w_0 . This means that the subgrade coefficient c now is

$$c = \frac{\tau_f}{w_0} = \frac{K_0 \tan \delta \gamma'}{w_0} z. \quad (6.49)$$

In the elastic region the basic differential equation now is

$$\frac{d^2 w}{dz^2} - \frac{zw}{b^3} = 0, \quad (6.50)$$

where b is a characteristic length, defined by

$$b^3 = \frac{EA w_0}{K_0 \tan \delta \gamma' O}. \quad (6.51)$$

The general solution of the differential equation (6.50) is

$$w = C_1 \text{Ai}(z/b) + C_2 \text{Bi}(z/b), \quad (6.52)$$

where the functions $\text{Ai}(z)$ and $\text{Bi}(z)$ are Airy functions, see the Appendix.

Solution for an infinitely long pile

For an infinitely long pile the solution vanishing at infinity is

$$w = C_1 \text{Ai}(z/b). \quad (6.53)$$

The boundary condition at the upper boundary of the elastic region is

$$z = d : w = w_0. \quad (6.54)$$

The constant C_1 can now easily be determined, and the final expression for the displacement in the elastic range is

$$w = w_0 \frac{\text{Ai}(z/b)}{\text{Ai}(d/b)}. \quad (6.55)$$

In the plastic region, for $0 < z < d$, the differential equation is

$$\frac{d^2 w}{dz^2} = \frac{K_0 \tan \delta \gamma' O}{EA} z = \frac{w_0 z}{b^3}. \quad (6.56)$$

This differential equation can easily be integrated,

$$w = \frac{w_0 z^3}{6b^3} + C_3 z + C_4. \quad (6.57)$$

Using the boundary condition at the top of the pile ($N = -P$), and the continuity conditions at the interface $z = d$, the integration constants can be determined, and a relation to determine the load P for a given plastic depth d is obtained. It is left to the reader to verify that this relation between P and d is

$$\frac{P}{EA} = \frac{w_0}{b} \left[\frac{d^2}{2b^2} - \frac{\text{Ai}'(d/b)}{\text{Ai}(d/b)} \right], \quad (6.58)$$

and that the displacement at the top of the pile is given by

$$\frac{w_t}{w_0} = 1 + \frac{d^3}{b^3} - \frac{d}{b} \frac{\text{Ai}'(d/b)}{\text{Ai}(d/b)}. \quad (6.59)$$

Equations (6.58) and (6.59) are a parameter representation of the load-displacement curve, see figure 6.9. As the pile is infinitely long, there is no finite limit load. As the load increases the plastic region will increase, but there always remains an elastic part, although this may be located infinitely deep.

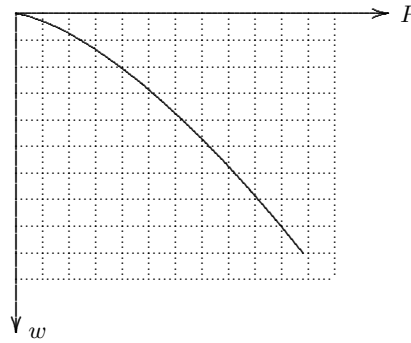

Figure 6.9: Load-displacement curve.

6.4 Bearing capacity

The analytic solutions presented in the previous sections may give some insight into the significance of the various physical parameters. They are also useful to validate more general numerical solution techniques. The solutions given are not very useful for civil engineering practice, however, because they are mainly restricted to piles of infinite length. Both for clay and for sand no finite limit load was found, for instance, and such a limit load is of great importance for the design of pile foundations. Therefore in this section this limit load will be considered in some detail. It will appear that no information is obtained about the deformations prior to failure. The principle of load transfer by a pile is sketched in figure 6.10. Part of the load is transferred to the soil by friction along the shaft of the pile, and another part is transferred to the soil below the pile by point bearing. We will write

$$P_c = P_f + P_q, \quad (6.60)$$

where P_f is the contribution to the limit load P_c of the friction, and P_q is the contribution of the point resistance.

There are several approaches possible for the determination of the maximum load that a pile can carry (the *bearing capacity* of the pile).

6.4.1 Theoretical approach

A theoretical approach to the bearing capacity problem is to determine both components from theoretical considerations.

For the shear stress along the shaft of the pile one may write

$$\tau_{max} = c + \sigma'_h \tan \delta = c + K_0 \tan \delta \sigma'_v. \quad (6.61)$$



Figure 6.10: Load transfer by a pile.

The total contribution of the friction to the bearing capacity of the pile is now found by integration along the pile shaft,

$$P_f = \int_0^l (c + K_0 \tan \delta \sigma'_v) O dz. \quad (6.62)$$

Thus the value of P_f can be determined if the values of the parameters c , K_0 , δ and σ'_v and O are known, or can be estimated. Unfortunately, this is not a trivial matter, and may require careful soil investigation.

The point bearing capacity can be estimated from a theoretical analysis following the theory developed by Prandtl, Terzaghi and Brinch Hansen. The formula to be used is

$$q_c = s_c N_c c + s_q N_q \sigma'_v. \quad (6.63)$$

The shape factors s_c and s_q for a square or a circular region are often taken as $s_c = 1.2$ and $s_q = 1 + \sin \phi$. The values of the bearing capacity coefficients N_c and N_q strongly depend upon the value of the friction angle ϕ . For $\phi = 30^\circ$ they are $N_c = 30$ and $N_q = 18$. In order to obtain the total force the limit stress q_c should be multiplied by the area of the pile foot,

$$P_q = q_c A. \quad (6.64)$$

Although this theoretical method requires knowledge about a great number of soil parameters, these may well be estimated, on the basis of experience and global information about the site. Thus, an experienced engineer may perform a first estimation on the basis of data from a geological map or survey, and some information about the type of soil.

6.4.2 Cone penetration test

Very valuable information about the soil may be obtained from a cone penetration test (CPT). Actually, this test was developed in The Netherlands with the explicit purpose to serve as a model test for a pile. By measuring the point resistance of a small rod being pushed into the ground, the value of q_c is measured directly. It may be noted that the bearing capacity formulas provide theoretical support for the CPT-analysis, as the maximum stress q_c is independent of the area of the pile or rod.

The friction can also be measured, by measuring the stress in the cone at two locations. Thus the maximum shear stress is also measured directly, and this can immediately be integrated along the shaft of the pile.

$$P_f = \int_0^l \tau_{max} O dz. \quad (6.65)$$

Thus the CPT data lead directly to a prediction of the bearing capacity.

6.4.3 Static pile loading test

In some countries it is required to perform at least one large scale pile loading test for a pile foundation. Of course this is an excellent method to determine the bearing capacity, but it requires heavy equipment, and a test pile, so that it is a very expensive method.

6.4.4 Dynamic pile loading test

A modern technique to predict the static bearing capacity of a pile is to use the information obtained from a dynamic test on a pile. The dynamic test may be the driving of the pile, or it may be a special test performed after installation of the pile. The principle of the method is to load the pile by a dynamic pulse (dropping a weight on its top), and then to measure the response of the pile top, for instance by measuring the displacement, the velocity or the acceleration. The interpretation of the test is usually done by comparing the response of the pile with the theoretical response of a model in which the soil-pile-interaction is taken into account.

The driving formulas that can be found in some early books on foundation engineering, and that are sometimes still used by experienced engineers, can be considered as an early version of dynamic pile testing. It should be noted that there is a large variety of driving formulas, which indicates that the correlation is not so simple as these formulas suggest. The modern way of analyzing dynamic pile testing is more sophisticated, and at least has a theoretical basis.

6.4.5 Plug in tubular piles

In the case of hollow tubular steel piles friction may develop not only with the soil surrounding the pile, but also with the soil in the pile. When the force is very small the pile will not slip along the soil, and the soil in the pile will act as an internal plug, going down with the pile. At the tip of the pile point resistance will act on the plug, causing shear stress transfer to the pile. As the point resistance develops these shear

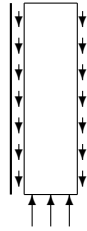

Figure 6.11: Load transfer by a plug.

stresses will increase, and may become so large that the soil slips along the inner pile wall. This will start at the bottom of the plug, and may gradually extend in upward direction. There are two limiting situations. The first is that the soil below the pile reaches its limiting bearing capacity. From that moment on the force at the pile tip can no longer increase. Part of the soil inside the pile (near the pile top) will never reach its maximum shear stress. The other limiting condition is when the point resistance is so large that the entire plug slips along the inner pile wall. The point resistance at the bottom of the plug will then never reach its maximum.

The first limiting force is

$$P_1 = q_c A_p, \quad (6.66)$$

where A_p is the area of the plug and the pile wall, i.e. the total area of the pile and the soil inside it. For a circular tube this is $A_p = \frac{1}{4}\pi D^2$, where D is the outer diameter of the pile.

The second limiting force is

$$P_2 = \int_0^l \tau_{max} O_i dz + q_c A_w, \quad (6.67)$$

where O_i is the circumference of the plug. For a circular pile this is $O_i = \pi D_i$, where D_i is the inner diameter of the pile. The point resistance of the steel wall has been added to the integral of the friction, as this can always develop.

The smallest of the two forces P_1 and P_2 may be added to the force representing the maximum friction of the outer wall to give the total bearing capacity of the pile.

A positive effect in the case of hollow piles is that the compressive stresses in the soil plug will result in an increase of the horizontal stresses inside the pile, and thus in an increase of the maximum possible shear stress. Because of the difficulty to evaluate this effect quantitatively it is usually disregarded. It gives some additional safety, however.

6.5 Dynamic effects

One may wonder under what conditions of dynamic loading of a pile inertia effects have to be taken into account. This problem is considered in this section, concentrating on the dynamic loads of structures such as an offshore platform loaded by wave action. The basic differential equation is the extension of eq. (6.5) to the dynamic case,

$$EA \frac{\partial^2 w}{\partial z^2} - cOw = \rho A \frac{\partial w}{\partial t^2}, \quad (6.68)$$

where ρ is the density of the pile material (steel or concrete). It is now assumed that the load is periodic, with an angular frequency ω , so that the response of the pile can also be expected to be periodic, with the same frequency. Thus one may write

$$w = \tilde{w} \exp(i\omega t), \quad (6.69)$$

where \tilde{w} is assumed to be a function of z only. Substitution into eq. (6.68) now gives

$$EA \frac{d\tilde{w}}{dz^2} - cO(1 - \frac{\rho A \omega^2}{cO})\tilde{w} = 0. \quad (6.70)$$

The relative importance of inertia effects of the pile is determined by the value of the parameter $\rho A \omega^2 / cO$.

For a steel tubular pile the ratio $A/O = d$, where d is the wall thickness of the pile. Furthermore the subgrade coefficient can be estimated to be

$$c = \frac{\tau_{max}}{w_0} \approx \frac{0.2\sigma'_v}{0.01D}. \quad (6.71)$$

If the vertical effective stress is evaluated at a depth of one half of the pile length, one obtains

$$c \approx \frac{10\gamma'l}{D} \approx \frac{10\rho'gl}{D}, \quad (6.72)$$

where ρ' is the density of the soil under water, and g is the gravity constant. The inertia parameter now becomes

$$\frac{\rho A \omega^2}{cO} \approx \frac{\rho d D \omega^2}{10\rho'gl} \approx \frac{dD\omega^2}{gl}. \quad (6.73)$$

For a typical pile one may estimate $D = 1$ m, $d = 0.05$ m, $g = 10$ m/s², $l = 20$ m. Then

$$\frac{\rho A \omega^2}{cO} \approx \frac{\omega^2}{4000 \text{ s}^{-2}}. \quad (6.74)$$

For normal loading conditions of a structure, with dynamic loads due to wave loading of an offshore platform, for instance, this parameter is always very small. Typical wave periods are about 10 seconds, and in that case $\omega \approx 0.6 \text{ s}^{-1}$. Thus inertia effects may usually be disregarded.

It may be noted that this conclusion is not true for the dynamic loads occurring during pile driving. These effects are not considered here, however.

6.6 Numerical analysis

In this section a numerical model for the analysis of stress transfer from a pile to the soil is considered. Load transfer takes place through friction along the shaft of the pile, and at the point by point resistance. The characteristics of both forms of stress transfer are in general non-linear. A simple computer program will be developed.

6.6.1 Basic equations

Consider a pile of length l , loaded at its top by a force P , see figure 6.12. The pile is subdivided into n elements, of possibly variable length

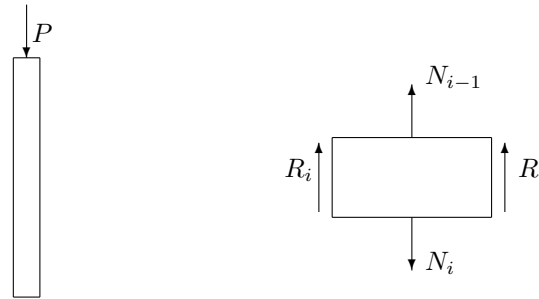

Figure 6.12: Axially loaded pile.

d_i and axial stiffness EA_i . The elements are numbered from $i = 1$ to $i = n$, and the nodal points are numbered from $i = 0$ to $i = n$, so that element i is located between the points $i - 1$ and i . The normal force in the pile acting at node i is denoted by N_i , and the friction force acting on the side of element i is denoted by R_i . This is the resultant force of the shear stresses.

The stress in an element is determined by the average normal force, and with Hooke's law the increment of the length of the element is

$$\frac{w_i - w_{i-1}}{d_i} = \frac{N_i + N_{i-1}}{2EA_i}, \quad (6.75)$$

or

$$\frac{2EA_i}{d_i}(w_i - w_{i-1}) = N_i + N_{i-1}. \quad (6.76)$$

For the next element the equation is

$$\frac{2EA_{i+1}}{d_{i+1}}(w_{i+1} - w_i) = N_{i+1} + N_i. \quad (6.77)$$

Subtraction of these two equations gives

$$B_{i+1}w_{i+1} - (B_{i+1} + B_i)w_i + B_iw_{i-1} = N_{i+1} - N_{i-1}, \quad (6.78)$$

where

$$B_i = \frac{2EA_i}{d_i}. \quad (6.79)$$

The normal forces can be eliminated by considering the equations of equilibrium of element i and element $i + 1$,

$$N_i - N_{i-1} = R_i, \quad (6.80)$$

$$N_{i+1} - N_i = R_{i+1}. \quad (6.81)$$

By adding these two equations one obtains

$$N_{i+1} - N_{i-1} = R_{i+1} + R_i. \quad (6.82)$$

Substituting this result into eq. (6.78) gives

$$B_{i+1}w_{i+1} - (B_{i+1} + B_i)w_i + B_iw_{i-1} = R_{i+1} + R_i. \quad (6.83)$$

This is the finite difference form of the differential equation

$$EA \frac{d^2w}{dz^2} = \tau O. \quad (6.84)$$

When all element lengths are equal, and the stiffness EA is constant, the finite difference equation (6.83) reduces to the well known standard form, with coefficients 1, -2, 1.

The friction force R_i along element i is determined by the average displacement v_i ,

$$v_i = \frac{1}{2}(w_{i-1} + w_i). \quad (6.85)$$

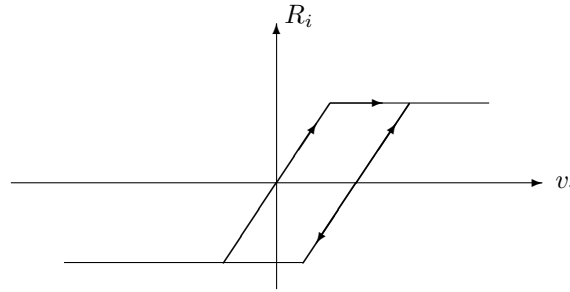

Figure 6.13: Soil response.

The response of the soil to the displacement of the pile is shown, in principle, in figure 6.13. The response is elastic if the shear stress is smaller than the limiting value, and plastic when the shear stress reaches that limit. When the displacement is reversed after some plastic deformation the response is again elastic. This type of behaviour can be described by a formula of the general form

$$R_i = S_i(v_i - \bar{v}_i) + T_i. \quad (6.86)$$

Here \bar{v}_i is the accumulated plastic deformation, S_i is the slope of the response curve, which may be zero, and T_i may have a value in the plastic branches.

In a numerical model it is most convenient to use a switch parameter to denote the various branches of the response curve. Let this parameter be denoted by p_i , and let its value be 0 in the elastic branch, 1 in the positive plastic branch, and -1 in the negative plastic branch. The precise definition is

$$\text{if } |v_i - \bar{v}_i| \leq v_i^0 \quad : \quad p_i = 0, \quad (6.87)$$

$$\text{if } (v_i - \bar{v}_i) > v_i^0 \quad : \quad p_i = 1, \quad (6.88)$$

$$\text{if } (v_i - \bar{v}_i) < -v_i^0 \quad : \quad p_i = -1. \quad (6.89)$$

In these equations v_i^0 is the quake in element i , and \bar{v}_i is the accumulated plastic strain, which is determined by the loading history of the element. Its value is assumed to be known.

Using the switch parameter p_i , the values of S_i and T_i can be defined as follows,

$$\text{if } p_i = -1 \quad : \quad S_i = 0, \quad T_i = -T_i^0, \quad (6.90)$$

$$\text{if } p_i = 0 : S_i = T_i^0/v_i^0, \quad T_i = 0, \quad (6.91)$$

$$\text{if } p_i = 1 : S_i = 0, \quad T_i = T_i^0, \quad (6.92)$$

where T_i^0 is the maximum shear force on element i , the product of the area $O_i d_i$ and the maximum shear stress τ_i^0 .

After completion of a loading step the accumulated plastic strain must be updated,

$$\text{if } (v_i - \bar{v}_i) > v_i^0 : \bar{v}_i = v_i - v_i^0, \quad (6.93)$$

$$\text{if } (v_i - \bar{v}_i) < -v_i^0 : \bar{v}_i = v_i + v_i^0. \quad (6.94)$$

By this updating procedure it is ensured that during unloading after plastic deformation, the response is again elastic, and that in further reloading the response is elasto-plastic, as indicated in figure 6.13.

With (6.86) and (6.85) the basic difference equation becomes

$$C_{i+1}w_{i+1} + C_i w_i + C_{i-1}w_{i-1} = T_{i+1} + T_i - S_{i+1}\bar{v}_{i+1} - S_i\bar{v}_i, \quad (6.95)$$

where

$$C_{i+1} = \frac{2EA_{i+1}}{d_{i+1}} - \frac{1}{2}S_{i+1}, \quad (6.96)$$

$$C_i = -\frac{2EA_i}{d_i} - \frac{2EA_{i+1}}{d_{i+1}} - \frac{1}{2}S_i - \frac{1}{2}S_{i+1}, \quad (6.97)$$

$$C_{i-1} = \frac{2EA_i}{d_i} - \frac{1}{2}S_i. \quad (6.98)$$

The system of equations (6.95) is the basic system of linear equations that must be solved. The system of equations is positive-definite, with a dominating main diagonal, so that its numerical solution should present no difficulties. Unfortunately, the value of the switch parameter is initially unknown, so that an iterative procedure has to be followed to find the solution. Usually it is most convenient to start the process by assuming that all soil responses are in the elastic branch, i.e. $p_i = 0$, then to determine the displacements w_i , and then to check the switch parameters. If any of these was estimated incorrectly the process has to be repeated with the improved values of the switches.

Equation (6.95) applies for $i = 1, \dots, n-1$, and contains $n+1$ variables. The remaining two equations can be obtained by considering the boundary conditions.

Pile top

The boundary condition at the top of the pile is that the normal force is given, $N_0 = -P$. In order to incorporate this condition into the system of equations it should be transformed into a condition in terms of the displacements. For this purpose Hooke's law for the first element may be

used, see eq. (6.76) with $i = 1$,

$$\frac{2EA_1}{d_1}(w_1 - w_0) = N_1 + N_0. \quad (6.99)$$

The normal force N_1 can be eliminated from this equation by using the equilibrium equation of the first element, that is eq. (6.80) with $i = 1$,

$$N_1 - N_0 = R_1, \quad (6.100)$$

One now obtains, with $N_0 = -P$, and using the expressions (6.86) and (6.85),

$$-\left(\frac{2EA_1}{d_1} + \frac{1}{2}S_1\right)w_0 + \left(\frac{2EA_1}{d_1} - \frac{1}{2}S_1\right)w_1 = T_1 - S_1\bar{v}_i - 2P. \quad (6.101)$$

This equation can be added to the system of equations. It can be considered as equation number 0.

Pile point

The boundary condition at the point of the pile is supposed to be such that there is a maximum force P_p , which is reached if the displacement of the lowest element of the pile reaches a critical value, the quake of the pile point q_p . In general the expression for the normal force at the foot of the pile can be written as

$$N_n = -c_p(w_n - w_p) - F_p, \quad (6.102)$$

where c_p is a spring constant, $c_p = P_p/q_p$ in the elastic region, and zero as soon as the maximum force is reached (the plastic region), or when the force tends to become negative. The parameter w_p indicates the accumulated plastic deformation, and F_p is either zero, in the elastic region, P_p in the plastic region in compression, and zero in the plastic region in tension. After each loading step the memory function w_p must be updated, to account for the permanent plastic deformation.

The boundary condition can be expressed mathematically by first using Hooke's law for the last element,

$$\frac{2EA_n}{d_n}(w_n - w_{n-1}) = N_n + N_{n-1}. \quad (6.103)$$

The normal force N_{n-1} can be eliminated by using the equilibrium equation of the last element,

$$N_n - N_{n-1} = R_n, \quad (6.104)$$

The final result can be obtained by using the general expressions (6.86) and (6.85) and eq. (6.102),

$$-\left(\frac{2EA_n}{d_n} + 2c_p + \frac{1}{2}S_n\right)w_n + \left(\frac{2EA_n}{d_n} - \frac{1}{2}S_n\right)w_{n-1} = T_n - S_n\bar{v}_n + 2F_p. \quad (6.105)$$

This is the final form of the boundary condition at the pile point. It can be considered as equation number n in the system of equations. Again it is an equation in terms of the basic variables w_i . Because certain coefficients, notably c_p and F_p depend upon the range of the displacements, an iterative procedure must be used to solve the system of equations.

The system of $n + 1$ equations, consisting of (6.95), (6.101) and (6.105) can be solved by a convenient numerical procedure, for instance Gauss elimination.

6.6.2 Computer program

An elementary computer program, in Turbo Pascal, is reproduced below, as program ALP. The program applies only to a homogeneous soil and pile, although certain facilities have been built in which may facilitate generalization of the program to the more general case of a pile in a layered soil. The program uses interactive input, and gives output in the form of the displacement of the top for a given value of the force at the top. The program can easily be modified to give graphical output, or output on a printer.

```

program alp;
uses crt;
const
  maxel=500;maxwid=4;maxit=100;
var
  length,stiff,ircum,fric,quake,point,quakep:real;
  dz,tz,sz,cp,fa,fp,wp:real;
  step,nel,steps,nerr,mp,mq,plast,it:integer;
  z,w,f,d,s,t,wm,ea,ss,ta,tb:array[0..maxel] of real;
  posquake,negquake:array[0..maxel] of real;
  p:array[0..maxel,1..maxwid] of real;
  kk:array[0..maxel,1..maxwid] of integer;
  np,nq:array[0..maxel] of integer;
procedure title;
begin
  clrscr;gotoxy(38,1);textbackground(7);textcolor(0);write(' ALP ');
  textbackground(0);textcolor(7);writeln;writeln;
end;
procedure next;
var
  a:char;
begin
  gotoxy(25,25);textbackground(7);textcolor(0);
  write(' Touch any key to continue ');write(chr(8));
  a:=readkey;textbackground(0);textcolor(7)
end;
procedure input;
```

```

var
  i:integer;
begin
  title;
  write('This is a program for the analysis of an axially loaded');
  writeln(' pile. ');writeln;
  write('Length of the pile (m) ..... ');readln(length);writeln;
  write('Axial stiffness EA (kN) ..... ');readln(stiff);writeln;
  write('Circumference (m) ..... ');readln(circum);writeln;
  write('Maximum friction (kN/m2) ..... ');readln(fric);writeln;
  write('Quake (m) ..... ');readln(quake);writeln;
  write('Point resistance (kN) ..... ');readln(point);writeln;
  write('Quake of the point (m) ..... ');readln(quakep);writeln;
  write('Number of elements (max. ',maxel,' .. ');readln(nel);writeln;
  write('Number of loading steps ..... ');readln(steps);writeln;
  if nel<10 then nel:=10;if nel>maxel then nel:=maxel;
  dz:=length/nel;tz:=dz*circum*fric;
  sz:=tz/quake;cp:=point/quakep;z[0]:=0;
  for i:=1 to nel do
    begin
      d[i]:=dz;ea[i]:=stiff;ss[i]:=sz;ta[i]:=tz;tb[i]:=tz;
      posquake[i]:=quake;negquake[i]:=quake;z[i]:=z[i-1]+dz;wm[i]:=0;np[i]:=0;
      mp:=0;wp:=0;
    end;
end;
procedure zeros;
var
  i:integer;
begin
  mp:=0;for i:=1 to nel do np[i]:=0;
end;
procedure initial;
var
  i:integer;
begin
  cp:=point/quakep;fp:=0;
  if mp=1 then begin cp:=0;fp:=point;end;
  if mp=-1 then begin cp:=0;fp:=0;end;
  for i:=1 to nel do
    begin
      s[i]:=ss[i];t[i]:=-ss[i]*wm[i];
      if np[i]=1 then begin s[i]:=0;t[i]:=ta[i];end;
      if np[i]=-1 then begin s[i]:=0;t[i]:=-tb[i];end;
    end;
end;

```

```

    end;
end;
procedure matrix;
var
  i,j:integer;a1,a2,b1,b2,c1:real;
begin
  for i:=0 to nel do for j:=1 to maxwid do
    begin
      kk[i,j]:=0;p[i,j]:=0;
    end;
  for i:=1 to nel-1 do
    begin
      kk[i,1]:=i;kk[i,2]:=i-1;kk[i,3]:=i+1;kk[i,maxwid]:=3;
    end;
  kk[0,1]:=0;kk[0,2]:=1;kk[0,maxwid]:=2;
  kk[nel,1]:=nel;kk[nel,2]:=nel-1;kk[nel,maxwid]:=2;
  for i:=1 to nel-1 do
    begin
      a1:=2*ea[i]/d[i];a2:=2*ea[i+1]/d[i+1];b1:=s[i]/2;b2:=s[i+1]/2;
      p[i,1]:=a1+a2+b1+b2;p[i,2]:=-a1+b1;p[i,3]:=-a2+b2;
      p[i,maxwid]:=-t[i]-t[i+1];
    end;
  a1:=2*ea[1]/d[1];b1:=s[1]/2;
  p[0,1]:=a1+b1;p[0,2]:=-a1+b1;p[0,maxwid]:=2*fa-t[1];
  a1:=2*ea[nel]/d[nel];b1:=s[nel]/2;c1:=2*cp;
  p[nel,1]:=a1+b1+c1;p[nel,2]:=-a1+b1;p[nel,maxwid]:=-2*fp-t[nel];
end;
procedure solve;
var
  i,j,k,l,kc,jj,jk,jl,ii,ij,ik:integer;c:real;
begin
  for i:=0 to nel do
    begin
      kc:=kk[i,maxwid];if kc>1 then
        begin
          for j:=2 to kc do
            begin
              if p[i,1]=0.0 then
                begin
                  writeln('Error : no equilibrium possible');halt;
                end;
              c:=p[i,j]/p[i,1];jj:=kk[i,j];
              p[jj,maxwid]:=p[jj,maxwid]-c*p[i,maxwid];l:=kk[jj,maxwid];
            end;
          end;
        end;
      end;
    end;
end;

```

```

for jl:=2 to 1 do begin if kk[jj,jl]=i then jk:=jl;end;
kk[jj,jk]:=kk[jj,1];kk[jj,1]:=0;
p[jj,jk]:=p[jj,1];p[jj,1]:=0;l:=l-1;kk[jj,maxwid]:=1;
for ii:=2 to kc do
begin
  ij:=0;
  for ik:=1 to 1 do
  begin
    if kk[jj,ik]=kk[i,ii] then ij:=ik;
  end;
  if ij=0 then
  begin
    l:=l+1;ij:=1;kk[jj,maxwid]:=1;kk[jj,ij]:=kk[i,ii];
  end;
  p[jj,ij]:=p[jj,ij]-c*p[i,ii];
end;
end;
if p[i,1]=0.0 then
begin
  writeln('Error : no equilibrium possible');halt;
end;
c:=1/p[i,1];for j:=1 to kc do p[i,j]:=c*p[i,j];
p[i,maxwid]:=c*p[i,maxwid];
end;
for i:=0 to nel do
begin
  j:=nel-i;l:=kk[j,maxwid];if l>1 then
  begin
    for k:=2 to 1 do
    begin
      jj:=kk[j,k];p[j,maxwid]:=p[j,maxwid]-p[j,k]*p[jj,maxwid];
    end;
  end;
end;
f[0]:=-fa;for i:=0 to nel do w[i]:=p[i,maxwid];
for i:=1 to nel do f[i]:=2*ea[i]*(w[i]-w[i-1])/d[i]-f[i-1];
end;
procedure checksprings;
var
  i:integer;aa,eps:real;
begin
  nerr:=0;plast:=0;eps:=0.000001;

```

```

for i:=1 to nel do
begin
  nq[i]:=0;aa:=(w[i]+w[i-1])/2-wm[i];
  if aa>posquake[i]+eps then nq[i]:=1;
  if aa<-negquake[i]-eps then nq[i]:=-1;
end;
for i:=1 to nel do
begin
  if nq[i]<>np[i] then begin np[i]:=nq[i];nerr:=nerr+1;end;
  if nq[i]<>0 then plast:=plast+1;
end;
aa:=w[nel]-wp;mq:=0;
if aa>quakep+eps then mq:=1;if aa<-eps then mq:=-1;
if mq<>mp then begin mp:=mq;nerr:=nerr+1;end;
if mq<>0 then plast:=plast+1;
end;
procedure update;
var
  i:integer;aa:real;
begin
  for i:=1 to nel do
  begin
    aa:=(w[i]+w[i-1])/2-wm[i];
    if aa>posquake[i] then wm[i]:=(w[i]+w[i-1])/2-posquake[i];
    if aa<-negquake[i] then wm[i]:=(w[i]+w[i-1])/2+negquake[i];
  end;
  aa:=w[nel]-wp;mq:=0;
  if aa>quakep then wp:=w[nel]-quakep;if aa<0 then wp:=w[nel];
end;
begin
input;
for step:=1 to steps do
begin
  title;it:=0;writeln('Loading step ',step);writeln;
  write('Force at the top (kN) ..... ');readln(fa);writeln;
  zeros;
  repeat
    initial;matrix;solve;checksprings;
    if plast=nel then begin writeln('Pile failed');nerr:=0;end;
    it:=it+1;if it=maxit then
      begin
        writeln('Warning : no convergence ');writeln;nerr:=0;
      end;
  until nerr=0;
end;

```



```

until nerr=0;
if plast<nsl then
begin
  writeln('Displacement at the top (m) ..... ',w[0]:8:6);
  writeln;
  writeln('Number of plastic springs ..... ',plast);
  next;update;
end
else step:=steps;
end;
title;
end.

```

Program ALP.

As an application of the program an example has been elaborated. The example applies to a steel tubular pile of 50 m length, with a diameter of 1 m, and a wall thickness of 0.05 m. This means that the pile area is 0.1492 m², and that the circumference (considering friction at the outer surface only) is 3.1416 m. The soil properties are that the maximum friction force is 50 kN/m², and that the quake is 0.01 m. The

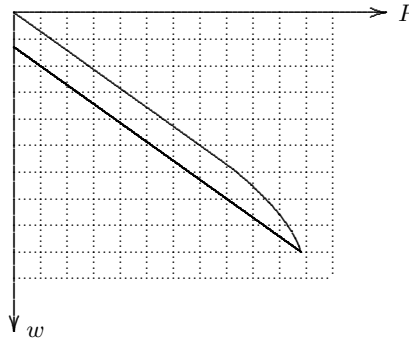

Figure 6.14: Example of axially loaded pile.

load-displacement curve for a cyclic load is shown in figure 6.14.

It is interesting to note that plastic deformations start to occur only close to the limit load. This is due to the fact that the pile is so stiff. In order to understand this behaviour better, one may note that the maximum force can be determined by integrating the shear stress along the area of the pile. This gives a maximum force of 7854 kN. At failure the average force in the pile is 3927 kN, and the displacement near the pile point is 0.01 m, the displacement necessary to let the last spring fail. The elastic deformation of the pile can be determined from the average

normal force, and is found to be 0.00627 m. Thus the deformation at the top of the pile is 0.01627 m, which is only slightly larger than the quake. Actually, the first spring fails at a displacement of 0.01 m (at the top), and this displacement is reached only for a value of the force of 6000 kN.

It can also be seen from the figure that the behaviour in unloading and reloading is completely elastic. The displacement difference is less than twice the quake, which is the maximum possible range of elasticity. In the theory of plasticity this type of behaviour is known as *shakedown*. The permanent deformations are such that after certain initial plastic deformations a system of initial stresses is left in the structure, so that it is possible that no further plastic deformations occur. Plastic deformations start to occur again only when the force exceeds the previous maximum.

6.6.3 Advanced computer program

A somewhat more advanced computer program, ALP99, is distributed by the Geotechnical Laboratory of the Delft University of Technology. This program is applicable to a pile in a layered soil (maximum 20 layers), where in each layer the soil parameters may be different. The program calculates the displacements due to a variable axial load, and stores the results in a datafile, which may be used for later graphical output.

6.7 Appendix : Airy Functions

The differential equation

$$\frac{d^2w}{dz^2} - zw = 0, \quad (6.106)$$

can be solved by assuming solutions in the form of a series

$$w = a_0 + a_1z + a_2z^2 + a_3z^3 + \dots \quad (6.107)$$

By taking convenient combinations of the two elementary solutions an increasing and a decreasing function can be constructed. These are the *Airy functions*. The general solution can be written as

$$w = C_1 \text{Ai}(z) + C_2 \text{Bi}(z), \quad (6.108)$$

see Abramowitz & Stegun (1964), p. 446. Numerical values of the two functions and their first derivatives are given in table 6.1.

z	$Ai(z)$	$Bi(z)$	$Ai'(z)$	$Bi'(z)$
0.00	0.35503	0.61493	-0.25882	0.44829
0.05	0.34209	0.63735	-0.25839	0.44908
0.10	0.32920	0.65986	-0.25713	0.45151
0.15	0.31639	0.68253	-0.25512	0.45571
0.20	0.30370	0.70546	-0.25241	0.46179
0.25	0.29116	0.72875	-0.24906	0.46986
0.30	0.27881	0.75249	-0.24515	0.48005
0.35	0.26666	0.77679	-0.24072	0.49248
0.40	0.25474	0.80177	-0.23583	0.50728
0.45	0.24308	0.82756	-0.23055	0.52460
0.50	0.23169	0.85428	-0.22491	0.54457
0.55	0.22060	0.88206	-0.21898	0.56737
0.60	0.20980	0.91106	-0.21279	0.59314
0.65	0.19932	0.94143	-0.20640	0.62209
0.70	0.18916	0.97333	-0.19985	0.65440
0.75	0.17934	1.00693	-0.19318	0.69030
0.80	0.16985	1.04242	-0.18641	0.73001
0.85	0.16070	1.08000	-0.17960	0.77378
0.90	0.15189	1.11987	-0.17277	0.82190
0.95	0.14342	1.16227	-0.16594	0.87468
1.00	0.13529	1.20742	-0.15915	0.93243
1.50	0.07175	1.87872	-0.07951	1.54032
2.00	0.03493	3.29768	-0.03754	2.89999
2.50	0.01573	6.48183	-0.01660	5.95841
3.00	0.00659	14.03796	-0.00688	13.23343
3.50	0.00258	33.05763	-0.00267	31.62228
4.00	0.00095	83.85047	-0.00098	80.95951
4.50	0.00033	227.59384	-0.00034	221.14583
5.00	0.00011	657.81465	-0.00011	642.09178
5.50	0.00003	2016.64811	-0.00003	1975.24921
6.00	0.00001	6536.48809	-0.00001	6419.90234
6.50	0.00000	22341.04179	-0.00000	21989.01852
7.00	0.00000	80330.12539	-0.00000	79200.76666

Table 6.1: Airy functions.

Chapter 7

DEVELOPMENT OF PILE PLUG

In a hollow tubular foundation pile a soil plug may develop at the bottom of the pile. This plug consists of soil under a high compressive stress, so that its stiffness and its strength are very large. During pile driving the formation of such a plug may result in a very high driving resistance, which may hinder the driving process. In static conditions the presence of a plug may give a considerable contribution to the bearing capacity of the pile. In this chapter a theoretical numerical model is developed for the analysis of the stress transfer in a plug.

7.1 Linear elastic model

For the purpose of reference a simple linear elastic model will be developed first. The soil column is supposed to have a constant cross sectional area A , consisting of a constant modulus of elasticity E , and an effective volumetric weight γ . The circumference of the pile is denoted by O . Because the soil column is circular we may write $A = \pi D^2/4$ and $O = \pi D$, where D is the diameter of the column. The normal stress σ in the

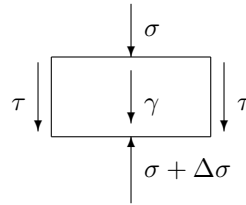

Figure 7.1: Element of axially loaded column of soil.

soil can be related to the friction along the circumference by the equation of equilibrium

$$A \frac{d\sigma}{dz} - \tau O - \gamma A = 0. \quad (7.1)$$

It can be assumed that the stresses due to the weight of the soil column are already acting in the soil before the pile is installed. This means that the deformation of the soil will be determined only by the incremental stresses. These are defined as

$$\sigma' = \sigma - \gamma z. \quad (7.2)$$

The equation of equilibrium for the incremental stress now is

$$A \frac{d\sigma'}{dz} - \tau O = 0. \quad (7.3)$$

The incremental stress σ' is related to the strain by Hooke's law for the soil material

$$\sigma' = -E\varepsilon = -E \frac{dw}{dz}. \quad (7.4)$$

Here the minus sign is necessary because the stresses have been assumed to be positive for compression. Substitution of eq. (7.4) into eq. (7.3) gives

$$EA \frac{d^2w}{dz^2} + \tau O = 0. \quad (7.5)$$

The further analysis depends upon the relation between the shear stress τ and the displacement w .

In this section it will be assumed that the shear stress τ is proportional to the relative displacement of the pile and the soil, $v - w$, where v is the (constant) vertical displacement of the pile. Hence

$$\tau = k(v - w), \quad (7.6)$$

where k has the character of a subgrade modulus. Substitution of eq. (7.6) in (7.5) gives

$$EA \frac{d^2w}{dz^2} - kO(w - v) = 0. \quad (7.7)$$

This is the basic differential equation for an elastic plug, with stress transfer from the pile through linear springs. The general solution of the differential equation (7.7) is

$$w = v + C_1 \exp(z/h) + C_2 \exp(-z/h), \quad (7.8)$$

where h is a characteristic length, defined by

$$h = \sqrt{EA/kO}, \quad (7.9)$$

and where C_1 and C_2 are integration constants, to be determined from the boundary conditions. For a plug of length L on a rigid base the boundary conditions are

$$z = 0 : \quad \sigma' = 0, \quad (7.10)$$

and

$$z = L : \quad w = 0. \quad (7.11)$$

The first boundary condition expresses that the top of the plug is free of stress, and the second one expresses that the bottom of the plug rests on a rigid base. Using the boundary conditions the constants C_1 and C_2 can be determined. The final expression for the vertical displacement then is

$$w = v - v \frac{\cosh(z/h)}{\cosh(L/h)}. \quad (7.12)$$

The corresponding formula for the incremental stress in the pile is

$$\sigma' = \frac{Ev}{h} \frac{\sinh(z/h)}{\cosh(L/h)}, \quad (7.13)$$

and the shear stress is found to be

$$\tau = kv \frac{\cosh(z/h)}{\cosh(L/h)}. \quad (7.14)$$

It can easily be seen that this solution satisfies the two boundary conditions. The actual stress in the pile is obtained by adding the initial stress (due to the weight of the soil) to the incremental stress. The shear stress distribution is shown graphically in figure 7.2, for the case that $L = 2h$.

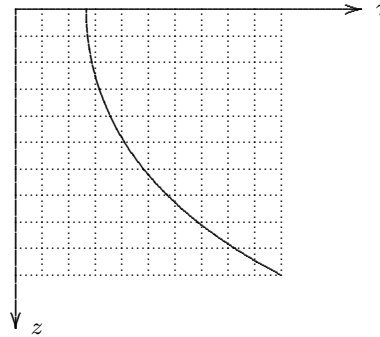

Figure 7.2: Shear stress, elastic springs.

The zone of influence of the force at the bottom of the pile is determined by the value of the parameter h . Therefore it is interesting to estimate the value of h , see eq. (7.9). The ratio of the modulus of elasticity E and the spring constant k can be estimated to be of the order of magnitude of the diameter D . This means that the value of h will be of the order of magnitude of $D/2$. It may be concluded that for normal piles (for

which the ratio of length to diameter is large), the value of L/h will be large. In that case the formula for the shear stress distribution (7.14) can be approximated by

$$\tau \approx kv \exp[-(L - z)/h]. \quad (7.15)$$

The shear stresses (and thus the plug) will be concentrated in a zone near the bottom of the pile, with a length of about 2 times the pile diameter.

7.2 Fully plastic model

The limiting situation, in which the shear stress along the pile shaft has reached its maximum value everywhere, has been considered by Randolph (1988). The basic equation is again the equation of equilibrium (7.1),

$$A \frac{d\sigma}{dz} - \tau O - \gamma A = 0. \quad (7.16)$$

The shear stress τ is now supposed to be determined by a friction factor times the horizontal stress, which in its turn is related to the vertical normal stress σ . The two factors can be combined into one, by writing

$$\tau = \beta\sigma, \quad (7.17)$$

where β can be considered to be of the order of magnitude of the product of the coefficient of neutral earth pressure K_0 and the friction coefficient $\tan \delta$,

$$\beta = K_0 \tan \delta. \quad (7.18)$$

It should be noted that in this case the total stress σ , which includes the initial stress due to the weight of the soil, should be used in the analysis, and not the incremental stress. With (7.17) the basic equation (7.16) becomes

$$\frac{d\sigma}{dz} = \frac{4\beta}{D}\sigma + \gamma. \quad (7.19)$$

The solution of this differential equation satisfying the condition that $\sigma = 0$ at the top of the pile ($z = 0$) is

$$\sigma = \frac{\gamma D}{4\beta} \left\{ \exp\left(\frac{4\beta z}{D}\right) - 1 \right\}. \quad (7.20)$$

The stress at the bottom of the plug is obtained by taking $z = L$ in eq. (7.20). When the factor $4\beta L/D$ is large compared to 1 the force at the bottom of the plug will be very large.

The shear stress distribution is, with (7.17) and (7.20),

$$\tau = \frac{\gamma D}{4} \left\{ \exp\left(\frac{4\beta z}{D}\right) - 1 \right\}. \quad (7.21)$$

For the case that $\beta = 0.25$ and $L = 2D$ the shear stress distribution is shown in figure 7.3.

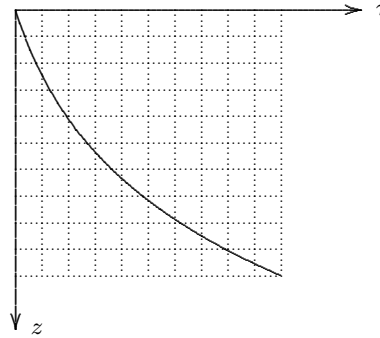
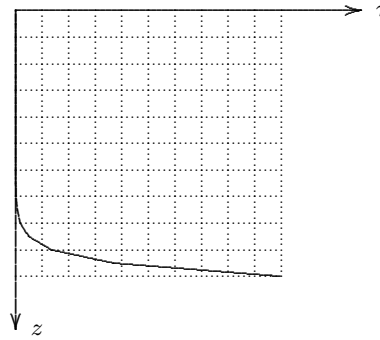

Figure 7.3: Shear stress, plastic springs, $L/D = 2$.

In most practical cases the value of the parameter L/D will be much larger than 2. Then the shear stresses are concentrated near the bottom of the plug, again indicating that the plug develops near the bottom end of the pile. This behaviour is shown in figure 7.4 for the case that $\beta = 0.25$ and $L/D = 20$.

7.3 Numerical analysis

In this section a numerical model for the analysis of stress transfer from a tubular pile to the soil in its interior is considered. Load transfer takes place through friction along the shaft of the pile. The characteristics of this form of stress transfer are in general non-linear, with an elastic branch up to a certain characteristic displacement, and a plastic branch, with a given shear stress, beyond that displacement. The purpose of this analysis is to extend the two simple models presented above, and to develop a useful general tool. The linear elastic case and the fully plastic case can of course be used as validations of the numerical model. The numerical model will be used to develop a computer program. A complete elasto-plastic finite element model has been developed by Leong & Randolph (1991). In that model the soil inside the pile has elasto-plastic properties, and slip at the soil-pile interface is modeled by interface elements. In the model presented here the soil inside the pile is represented as a non-linear elastic material, and slip at the soil-pile interface is modeled by (non-linear) elasto-plastic springs.

 Figure 7.4: Shear stress, plastic springs, $L/D = 20$.

7.3.1 Basic equations

Consider a pile of length L , loaded at its top by a force P , see figure 7.5. The pile is subdivided into n elements, of possibly variable length d_i and axial stiffness EA_i . The elements are numbered from $i = 1$ to $i = n$, and the nodal points are numbered from $i = 0$ to $i = n$, so that element i is located between the points $i - 1$ and i . The normal force in the pile acting at node i is denoted by N_i , and the friction force acting on the side of element i is denoted by T_i . This is the resultant force of the shear stresses.

The strain of an element is determined by the average normal stress in the soil column, but it should be noted that only the incremental stress, due to the shear stress transferred from the pile, leads to additional strains. Thus it is convenient to write

$$N_i = F_i + \gamma z_i. \quad (7.22)$$

The stress-strain relation for the soil column can now be expressed in terms of the average incremental stress in the element, in the form

$$\frac{w_i - w_{i-1}}{d_i} = -\frac{F_i + F_{i-1}}{2EA_i}, \quad (7.23)$$

or

$$\frac{2EA_i}{d_i}(w_i - w_{i-1}) = -F_i - F_{i-1}. \quad (7.24)$$

For the next element the equation is

$$\frac{2EA_{i+1}}{d_{i+1}}(w_{i+1} - w_i) = -F_{i+1} - F_i. \quad (7.25)$$

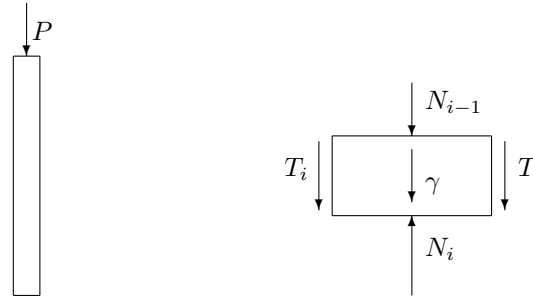

Figure 7.5: Stresses on plug.

Subtraction of these two equations gives

$$-B_{i+1}w_{i+1} + (B_{i+1} + B_i)w_i - B_iw_{i-1} = F_{i+1} - F_{i-1}, \quad (7.26)$$

where

$$B_i = \frac{2EA_i}{d_i}. \quad (7.27)$$

The normal forces can be eliminated by considering the equations of equilibrium of element i and element $i + 1$,

$$F_i - F_{i-1} = T_i, \quad (7.28)$$

$$F_{i+1} - F_i = T_{i+1}. \quad (7.29)$$

By adding these two equations one obtains

$$F_{i+1} - F_{i-1} = T_{i+1} + T_i. \quad (7.30)$$

Substituting this result into eq. (7.26) gives

$$-B_{i+1}w_{i+1} + (B_{i+1} + B_i)w_i - B_iw_{i-1} = T_{i+1} + T_i. \quad (7.31)$$

This is the finite difference form of the differential equation

$$EA \frac{d^2w}{dz^2} = -\tau O. \quad (7.32)$$

When all element lengths are equal, and the stiffness EA is constant, the finite difference equation (7.31) reduces to the well known standard form, with coefficients -1, +2, -1.

It is well known that for normal soils the stiffness increases as the stress increases. This can be taken into account by assuming that the modulus of elasticity is proportional to the average stress in an element,

$$EA_i = \frac{1}{2}C(N_{i-1} + N_i), \quad (7.33)$$

where C is a stiffness coefficient. Its value is usually of the order of magnitude of 50, for soft clay, up to 500 for dense sand.

The friction force T_i along element i is determined by the average displacement \bar{w}_i ,

$$\bar{w}_i = \frac{1}{2}(w_{i-1} + w_i). \quad (7.34)$$

The response of the soil to the displacement of the pile is shown, in principle, in figure 7.6. The response is elastic if the shear stress is smaller

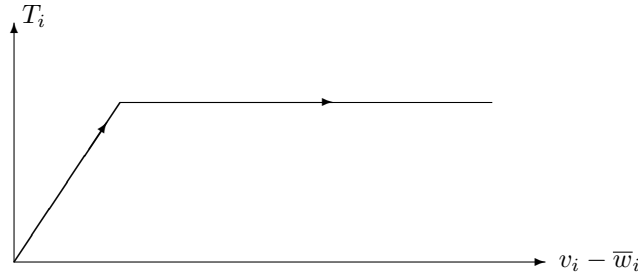

Figure 7.6: Soil response.

than a certain limiting value, and plastic when the shear stress reaches that limit. The limiting value can best be described in terms of the displacement. Then it can be stated that the elastic branch applies as long as the relative displacement of the pile with respect to the soil is smaller than a given value, the quake. It should be noted that in figure 7.6 it has been assumed that the displacement difference is always increasing. If the displacement difference would decrease, unloading would occur, with permanent plastic deformations. The response curve is then more complicated.

The behaviour can be described by a formula of the general form

$$T_i = S_i(v_i - \bar{w}_i) + T_i^*. \quad (7.35)$$

Here S_i is the slope of the response curve, which may be zero, and T_i^* will have a value only in the plastic branch.

In a numerical model it may be convenient to use a switch parameter to distinguish between the various branches of the response curve. This parameter will be denoted by p_i , and its value is 0 in the elastic branch, and 1 in the plastic branch. The precise definition is

$$\text{if } (v_i - \bar{w}_i) \leq w_i^0 \quad : \quad p_i = 0, \quad (7.36)$$

$$\text{if } (v_i - \bar{w}_i) > w_i^0 \quad : \quad p_i = 1. \quad (7.37)$$

In these equations w_i^0 is the quake in element i , which is supposed to be given. Using the switch parameter p_i , the values of S_i and T_i^* can be defined as follows

$$\text{if } p_i = 0 \quad : \quad S_i = T_i^0/w_i^0, \quad T_i^* = 0, \quad (7.38)$$

$$\text{if } p_i = 1 \quad : \quad S_i = 0, \quad T_i^* = T_i^0, \quad (7.39)$$

where T_i^0 is the maximum shear force on element i , the product of the area $O_i d_i$ and the maximum shear stress τ_i^0 . This maximum shear stress in its turn is determined by the normal stress in the plug, see eq. (7.17),

$$\tau_i^0 = \beta \sigma_i. \quad (7.40)$$

The normal stress σ_i can be calculated by dividing the normal force N_i (including the contribution of the weight of the soil) by the area A . During the development of the plug the normal stress will increase, and thus the maximum shear stress will increase. In the present model it is assumed that the quake remains constant, which then implies that the stiffness of the springs increases when the plug develops. This seems justified by the general observation that the stiffness of a soil increases with the stress level.

With (7.34) and (7.35) the basic difference equation (7.31) becomes

$$C_{i+1}w_{i+1} + C_i w_i + C_{i-1}w_{i-1} = T_{i+1}^* + T_i^* + S_{i+1}v_{i+1} + S_i v_i, \quad (7.41)$$

where

$$C_{i+1} = -\frac{2EA_{i+1}}{d_{i+1}} + \frac{1}{2}S_{i+1}, \quad (7.42)$$

$$C_i = +\frac{2EA_i}{d_i} + \frac{2EA_{i+1}}{d_{i+1}} + \frac{1}{2}S_i + \frac{1}{2}S_{i+1}, \quad (7.43)$$

$$C_{i-1} = -\frac{2EA_i}{d_i} + \frac{1}{2}S_i. \quad (7.44)$$

The system of equations (7.41) is the basic system of linear equations that must be solved. The system of equations is positive-definite, with a dominating main diagonal, so that its numerical solution should present no difficulties. Unfortunately, the value of the switch parameter is

initially unknown, so that an iterative procedure has to be followed to find the solution. Usually it is most convenient to start the process by assuming that all soil responses are in the elastic branch, i.e. $p_i = 0$, then to determine the displacements w_i , and then to check the switch parameters. If any of these was estimated incorrectly the process has to be repeated with the improved values of the switches. Because the limiting shear stress depends upon the stress level its value will increase during the process of displacement. This means that it will be necessary to apply the load (or the imposed displacement of the pile) in a large number of small steps.

Equation (7.41) applies for $i = 1, \dots, n - 1$, and contains $n + 1$ variables. The remaining two equations can be obtained by considering the boundary conditions.

Plug top

The boundary condition at the top of the plug is that the normal force is given, $F_0 = 0$. In order to incorporate this condition into the system of equations it should be transformed into a condition in terms of the displacements. For this purpose Hooke's law for the first element may be used, see eq. (7.24) with $i = 1$,

$$\frac{2EA_1}{d_1}(w_1 - w_0) = -F_1 - F_0. \quad (7.45)$$

The normal force F_1 can be eliminated from this equation by using the equilibrium equation of the first element, that is eq. (7.28) with $i = 1$,

$$F_1 - F_0 = T_1, \quad (7.46)$$

One now obtains, with $F_0 = 0$, and using the expressions (7.35) and (7.34),

$$\left(\frac{2EA_1}{d_1} + \frac{1}{2}S_1\right)w_0 - \left(\frac{2EA_1}{d_1} - \frac{1}{2}S_1\right)w_1 = T_1^* + S_1v_1. \quad (7.47)$$

This equation can be added to the system of equations. It can be considered as equation number 0.

Plug bottom

The boundary condition at the bottom of the plug is supposed to be that the displacement of the soil is zero there. Thus this boundary condition is simply

$$w_n = 0. \quad (7.48)$$

This can be considered as equation number n in the system of equations.

The system of $n + 1$ equations, consisting of (7.41), (7.47) and (7.48) can be solved by a convenient numerical procedure, for instance Gauss elimination.

7.3.2 Computer program

An elementary computer program, in Turbo Pascal, is reproduced below, as the program PLUG. The program applies only to a homogeneous soil and pile, although certain facilities have been built in which may facilitate generalization of the program to the more general case of a layered soil and a deformable pile. The program builds up the stresses and displacements in an incremental way, by applying the displacement of the pile in small steps. It is assumed that as soon as one of the springs has reached its maximum (plastic) value, it remains in the plastic range. Thus the program structure is suitable only for an ever increasing load, and cannot be applied for unloading, during which a plastic spring may return to the elastic range.

The program uses interactive input to enter the data, such as the length and the diameter of the plug, and the relevant soil data. Output is given in the form of a table, giving the distribution of the shear stresses. The limiting values of these stresses for the fully plastic case are also shown on the screen, for comparison.

```

program plug;
uses crt;
const
  nn=400;zz=4;
var
  maxx,maxy,graphdriver,graphmode,errorcode:integer;xasp,yasp:word;
  length,diam,elast,stiff,gamma,circum,area,fric,quake:real;
  dz,tz,wmax:real;step,n,steps,plast:integer;
  z,w,wz,f,fz,d,s,t,st,sz,v,ea,ss,ta,tb,qq:array[0..nn] of real;
  p:array[0..nn,1..zz] of real;pt:array[0..nn,1..zz] of integer;
  np:array[0..nn] of integer;
procedure title;
begin
  clrscr;gotoxy(37,1);textbackground(7);textcolor(0);write(' PLUG ');
  textbackground(0);textcolor(7);writeln;writeln;
end;
procedure next;
var
  a:char;
begin
  gotoxy(25,25);textbackground(7);textcolor(0);
  write(' Touch any key to continue ');write(chr(8));
  a:=readkey;textbackground(0);textcolor(7);
end;
procedure input;
var
  i:integer;pi,zm:real;
begin
  title;pi:=3.1415926;writeln('Input data :');writeln;

```

```

write('Length of the plug (m) ..... ');readln(length);
write('Diameter (m) ..... ');readln(diam);
write('Stiffness coefficient ..... ');readln(stiff);
write('Volumetric weight (kN/m3) ..... ');readln(gamma);
write('Friction coefficient ..... ');readln(fric);
write('Quake (m) ..... ');readln(quake);
write('Displacement of pile (m) ..... ');readln(wmax);
write('Number of elements (max. ',nn,') .. ');readln(n);
write('Number of loading steps ..... ');readln(steps);
if n<10 then n:=10;if n>nn then n:=nn;circum:=pi*diam;
area:=circum*diam/4;stiff:=stiff*area;dz:=length/n;plast:=0;z[0]:=0;
for i:=1 to n do
  begin
    d[i]:=dz;z[i]:=z[i-1]+d[i];qq[i]:=quake;zm:=0.5*(z[i-1]+z[i]);
    ea[i]:=stiff*gamma*zm;ta[i]:=fric*circum*d[i]*gamma*zm;
  end;
for i:=0 to n do
  begin
    v[i]:=wmax/steps;np[i]:=0;f[i]:=0;fz[i]:=0;sz[i]:=0;wz[i]:=0;
  end;
end;
procedure initial;
var
  i:integer;ff,zm,ss:real;
begin
  for i:=1 to n do
    begin
      zm:=0.5*(z[i-1]+z[i]);ff:=0.5*(fz[i-1]+fz[i]);
      ss:=ff/area+gamma*zm;ta[i]:=fric*circum*d[i]*ss;
      ea[i]:=stiff*ss;s[i]:=ta[i]/qq[i];t[i]:=s[i]*v[i];
      if np[i]>0 then t[i]:=0;
    end;
  end;
procedure matrix;
var
  i,j:integer;a1,a2,b1,b2,c1:real;
begin
  for i:=0 to n do for j:=1 to zz do
    begin
      pt[i,j]:=0;p[i,j]:=0;
    end;
  for i:=1 to n-1 do
    begin

```

```

    pt[i,1]:=i;pt[i,2]:=i-1;pt[i,3]:=i+1;pt[i,zz]:=3;
end;
pt[0,1]:=0;pt[0,2]:=1;pt[0,zz]:=2;pt[n,1]:=n;pt[n,zz]:=2;
for i:=1 to n-1 do
begin
    a1:=2*ea[i]/d[i];a2:=2*ea[i+1]/d[i+1];b1:=s[i]/2;b2:=s[i+1]/2;
    p[i,1]:=a1+a2+b1+b2;p[i,2]:=-a1+b1;p[i,3]:=-a2+b2;
    p[i,zz]:=t[i]+t[i+1];
end;
a1:=2*ea[1]/d[1];b1:=s[1]/2;
p[0,1]:=a1+b1;p[0,2]:=-a1+b1;p[0,zz]:=t[1];
p[n,1]:=1;p[n,2]:=0;p[n-1,3]:=0;p[n,zz]:=0;
end;
procedure solve;
var
    i,j,k,l,kc,jj,jk,jl,ii,ij,ik:integer;c:real;a:char;
begin
    for i:=0 to n do
    begin
        kc:=pt[i,zz];if kc>1 then
        begin
            for j:=2 to kc do
            begin
                if p[i,1]=0.0 then
                begin
                    writeln('Error : no equilibrium possible');halt;
                end;
                c:=p[i,j]/p[i,1];jj:=pt[i,j];
                p[jj,zz]:=p[jj,zz]-c*p[i,zz];l:=pt[jj,zz];
                for jl:=2 to l do begin if pt[jj,jl]=i then jk:=jl;end;
                pt[jj,jk]:=pt[jj,1];pt[jj,1]:=0;
                p[jj,jk]:=p[jj,1];p[jj,1]:=0;l:=l-1;pt[jj,zz]:=l;
                for ii:=2 to kc do
                begin
                    ij:=0;for ik:=1 to l do if pt[jj,ik]=pt[i,ii] then ij:=ik;
                    if ij=0 then
                    begin
                        l:=l+1;ij:=1;pt[jj,zz]:=l;pt[jj,ij]:=pt[i,ii];
                    end;
                    p[jj,ij]:=p[jj,ij]-c*p[i,ii];
                end;
            end;
        end;
    end;
end;
end;

```



```

    if p[i,1]=0.0 then
      begin
        writeln('Error : no equilibrium possible');halt;
      end;
    c:=1/p[i,1];for j:=1 to kc do p[i,j]:=c*p[i,j];p[i,zz]:=c*p[i,zz];
  end;
for i:=0 to n do
  begin
    j:=n-i;l:=pt[j,zz];if l>1 then
      for k:=2 to l do p[j,zz]:=p[j,zz]-p[j,k]*p[pt[j,k],zz];
    end;
  f[0]:=0;
  for i:=0 to n do
    begin
      w[i]:=p[i,zz];wz[i]:=wz[i]+w[i];
    end;
  for i:=1 to n do f[i]:=-2*ea[i]*(w[i]-w[i-1])/d[i]-f[i-1];
  st[0]:=0;for i:=1 to n do st[i]:=(f[i]-f[i-1])/(circum*d[i]);
  for i:=1 to n do
    begin
      fz[i]:=fz[i]+f[i];sz[i]:=sz[i]+st[i];
    end;
  end;
procedure checksprings;
var
  i:integer;ff,ss,zm,eps:real;
begin
  plast:=0;
  for i:=1 to n do
    begin
      ff:=0.5*(fz[i-1]+fz[i]);zm:=0.5*(z[i-1]+z[i]);
      ss:=ff/area+gamma*z; if (sz[i]>fric*ss) then np[i]:=1;
      if np[i]>0 then plast:=plast+1;
    end;
  end;
procedure output;
var
  i,k:integer;tt:real;
begin
  title;k:=0;
  write(' z          w          s          t');
  writeln('          tmax');
  for i:=0 to n do

```

```

begin
write(z[i]:6:3,wz[i]:12:6,fz[i]/area+gamma*z[i]:15:3);
if (i>0) then
begin
tt:=0.25*gamma*diam*(exp(2*fric*(z[i-1]+z[i])/diam)-1);
write(sz[i]:15:3,tt:15:3);
end;
writeln;k:=k+1;
if (k>20) then
begin
next;k:=1;title;
write(' z          w          s          t');
writeln('          tmax');
end;
end;
end;
begin
input;
for step:=1 to steps do
begin
title;writeln('Loading step ..... ',step:8);writeln;
writeln('Displacement of pile (m) ..... ',step*v[0]:15:6);writeln;
writeln('Displacement of plug (m) ..... ',wz[0]:15:6);writeln;
writeln('Force at the bottom (kN) ..... ',fz[n]:15:6);writeln;
writeln('Plastic springs ..... ',plast:8);
initial;matrix;solve;checksprings;
end;
output;clrscr;
end.

```

Program PLUG.

The results for a plug with a length of 5 m, a diameter of 1 m, a stiffness coefficient 500, volumetric weight 10 kN/m³, friction factor 0.25 and quake 0.01 m are shown in figure 7.7, if the displacement of the pile is 0.025 m. The fully drawn line is the shear stress as calculated by the numerical method. The dashed line represents the maximum shear stresses, as calculated using Randolph's fully plastic model. When the displacement of the pile is taken larger the numerical results will gradually approach the limiting values of the fully plastic solution. This can be seen as a validation of the numerical model.

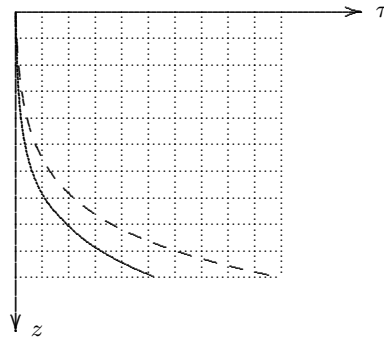

Figure 7.7: Shear stress, Numerical solution.

Chapter 8

LATERALLY LOADED PILES

Although foundation piles usually have as their main purpose to carry axial loads, they may also be subject to lateral loads. This is especially the case for offshore platforms, which may be loaded by large lateral forces due to wind and water waves. The response of a pile to a lateral load is studied in this chapter. Some analytic solutions for simplified problems will be presented first. In a later section a numerical model will be developed, which includes non-linear material behaviour.

Throughout this chapter the response of the soil next to the pile will be assumed to be determined only by the lateral displacement of the pile at that point. This means that all load transfer in the soil in vertical direction is disregarded. It also means that effects of plasticity can only be taken into account in as functions of the local displacement of the pile. Elastic solutions, for piles in a linear elastic medium, have been developed by Poulos (1986). A refined model, in which the soil is modeled as a system of elasto-plastic layers, has been developed by Kooijman (1989). This model also applies to the analysis of pile groups, even when the plastic zones of the individual piles in the pile group overlap. The model also has the feature that a gap between pile and soil may be develop at the upward side of the pile.

8.1 Pile in linear material

Consider a pile consisting of a linear elastic material, with modulus of elasticity E . The second order moment of the pile cross section in the direction of bending of the pile is I , so that the bending stiffness is EI . The pile is loaded by a lateral load f , see figure 8.1. The load f is related to the shear force Q by the equation of equilibrium in lateral direction

$$\frac{dQ}{dz} = -f. \quad (8.1)$$

Equilibrium of moments requires that

$$\frac{dM}{dz} = Q. \quad (8.2)$$

From these two equations it follows that

$$\frac{d^2M}{dz^2} = -f. \quad (8.3)$$

This is the well known relation between the bending moment in a beam and the load upon it.

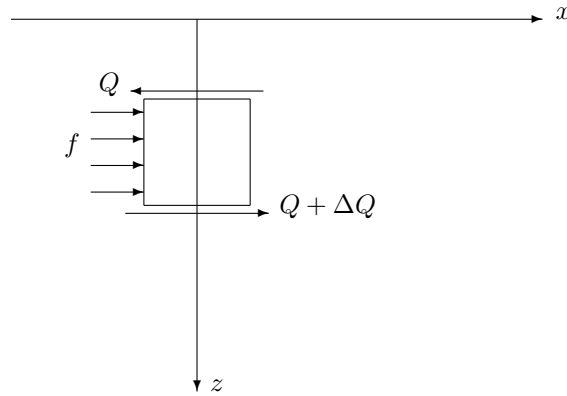

Figure 8.1: Element of laterally loaded pile.

The second basic equation describes the deformation of the pile. Using Bernoulli's assumption that plane normal sections remain plane this equation is found to be

$$EI \frac{d^2 u}{dz^2} = -M, \quad (8.4)$$

where u is the lateral displacement of the pile, in x -direction. The bending moment M can be eliminated from eqs. (8.3) and (8.4), to give

$$EI \frac{d^4 u}{dz^4} = f. \quad (8.5)$$

This is the well known basic equation of the theory of bending of beams.

In the case of a pile with lateral support, the load is generated by the lateral displacement u . In the simplest case the load is proportional to the displacement,

$$f = -ku, \quad (8.6)$$

where k is the subgrade modulus (in kN/m^3), and the minus sign is needed because when the displacement is to the right, the soil reaction will be to the left, see figure 8.1. Assuming that this is the only load on the pile, substitution of (8.6) into (8.5) gives

$$EI \frac{d^4 u}{dz^4} + ku = 0, \quad (8.7)$$

or

$$\frac{d^4 u}{dz^4} + \frac{4u}{\lambda^4} = 0, \quad (8.8)$$

where λ is a parameter of dimension length, defined as

$$\lambda^4 = \frac{4EI}{k}. \quad (8.9)$$

The general solution of the differential equation (8.8) is

$$u = C_1 \exp(z/\lambda) \cos(z/\lambda) + C_2 \exp(z/\lambda) \sin(z/\lambda) + C_3 \exp(-z/\lambda) \cos(z/\lambda) + C_4 \exp(-z/\lambda) \sin(z/\lambda). \quad (8.10)$$

The constants C_1 , C_2 , C_3 and C_4 must be determined from the boundary conditions. In general both boundaries will give rise to two conditions, so that the four constants can indeed be determined.

8.1.1 Solution for an infinitely long pile

In case of an infinitely long pile one of the boundaries is at $z = \infty$. The terms with $\exp(z/\lambda)$ then must be eliminated by taking $C_1 = 0$ and $C_2 = 0$. If it is assumed that the boundary conditions at the top of the pile are

$$z = 0 : \quad M = -EI \frac{d^2 u}{dz^2} = 0, \quad (8.11)$$

and

$$z = 0 : \quad Q = -EI \frac{d^3 u}{dz^3} = -P, \quad (8.12)$$

the final solution becomes

$$u = \frac{P\lambda^3}{2EI} \exp(-z/\lambda) \cos(z/\lambda). \quad (8.13)$$

This solution is shown graphically in figure 8.2. The displacement at the top of the pile will be denoted by u_t . Its value is

$$u_t = \frac{P\lambda^3}{2EI}. \quad (8.14)$$

The meaning of the parameter λ can be seen from figure 8.2. The displacement is zero if $z = \pi\lambda/2$, and after the next zero at $z = 3\pi\lambda/2$ the displacements are practically zero. Thus the influence of the load at the top can be felt to a depth of about 5λ . This also means that a pile longer than 5λ can be considered as infinitely long.

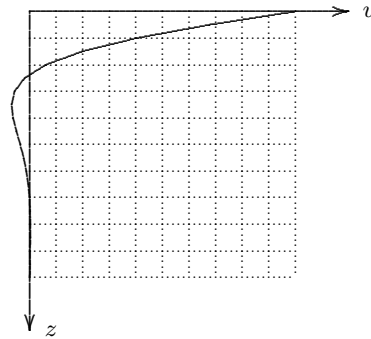

Figure 8.2: Laterally loaded pile in elastic material.

It is not surprising to note that the lateral displacement of the top of the pile u_t is proportional to the lateral load P . This is an immediate consequence of the linearity of the model used. It can also be seen from the solution (8.14) that the displacement is inversely proportional to the parameters $k^{3/4}$ and $EI^{1/4}$. This suggests that the pile stiffness EI is relatively unimportant, and that the soil stiffness k is very important for the soil response. It will appear later, when considering more realistic soil models, that these conclusions are not generally valid.

A variant of the problem solved in this section is to consider that the subgrade modulus increases linearly with depth. This may be a realistic assumption, as often the stiffness of the soil increases with the initial stress, which increases with depth. The analytical solution of this problem will not be considered here, however. In the next sections of this chapter a numerical model will be developed which includes the possibility of a stiffness increasing with depth.

8.2 Pile in perfectly plastic material

In this section an approximate analytic solution will be presented for the problem of a pile in a homogeneous material, taking into account the plastic deformations of the soil.

A fairly realistic assumption for the response of the soil to a lateral displacement is to consider this to be elasto-plastic, see figure 8.3. In this figure the response is assumed to be elastic if the displacement is small. It reaches its maximum value (the *passive* lateral soil pressure),

$$\sigma'_{h-max} = K_p \sigma'_v + 2c\sqrt{K_p}, \quad (8.15)$$

when the displacement reaches a certain positive value, and it reaches its minimum value (the *active* lateral soil pressure),

$$\sigma'_{h-min} = K_a \sigma'_v - 2c\sqrt{K_a}, \quad (8.16)$$

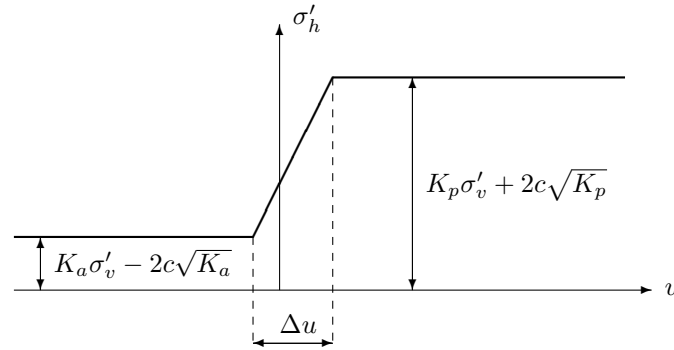

Figure 8.3: Elasto-plastic soil response.

when the displacement reaches a certain negative value. If the value obtained from eq. (8.16) is found to be negative the horizontal effective stress is zero, because tensile stresses cannot be transferred in a granular material. In the equations given above c is the cohesion of the soil, and K_a and K_p are the active and passive pressure coefficients,

$$K_a = \frac{1 - \sin \phi}{1 + \sin \phi}, \quad (8.17)$$

$$K_p = \frac{1 + \sin \phi}{1 - \sin \phi}, \quad (8.18)$$

where ϕ is the friction angle of the soil. The length of the range of elastic displacements (Δu in figure 8.3) is called the *stroke*. This is a similar quantity as the *quake*, used in the analysis of axially loaded piles. It represents the displacement difference between generating active and passive soil pressures, respectively.

The response shown in figure 8.3 will be used in the next section to develop a numerical model. In the present section a simplified analysis will first be presented, due to Blum (1931). In this analysis it is assumed that the elastic range is extremely small, see figure 8.4. This is called a perfectly plastic response. As soon as there is a displacement the response is either at its maximum or its minimum. If the load on the pile acts towards the right the force on the right side of the pile is the passive earth pressure, and the force on the left side of the pile is the active soil pressure. Thus the total force is

$$f = -(K_p - K_a)D\sigma'_v - 2cD(\sqrt{K_p} + \sqrt{K_a}), \quad (8.19)$$

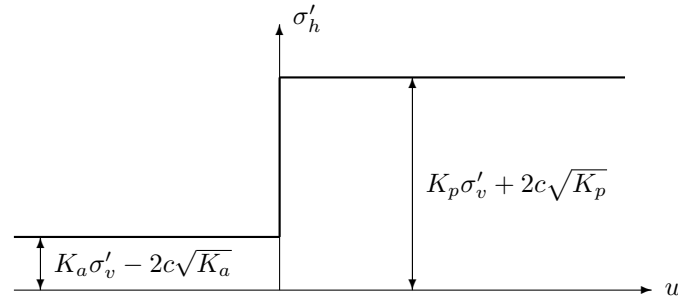

Figure 8.4: Perfectly plastic soil response.

or, assuming that the vertical effective stress increases linearly with depth,

$$f = -(K_p - K_a)D\gamma'z - 2cD(\sqrt{K_p} + \sqrt{K_a}), \quad (8.20)$$

where γ' is the submerged unit weight of the soil.

It is furthermore assumed that the distribution of the soil reaction is as shown in figure 8.5. The basic idea is that the pile is displaced towards the right by the applied force, except at the lower end, where a displacement towards the left occurs. The soil reaction on this deeper part of the pile, is replaced by a concentrated force (Blum's *Ersatzkraft*), further assuming that the pile is clamped at that depth.

The differential equation now is

$$EI \frac{d^4 u}{dz^4} = f = -(K_p - K_a)D\gamma'z - 2cD(\sqrt{K_p} + \sqrt{K_a}), \quad (8.21)$$

and the boundary conditions are

$$z = 0 : \quad Q = -P, \quad (8.22)$$

$$z = 0 : \quad M = 0, \quad (8.23)$$

$$z = h : \quad u = 0, \quad (8.24)$$

$$z = h : \quad \frac{du}{dz} = 0, \quad (8.25)$$

$$z = h : \quad M = 0. \quad (8.26)$$

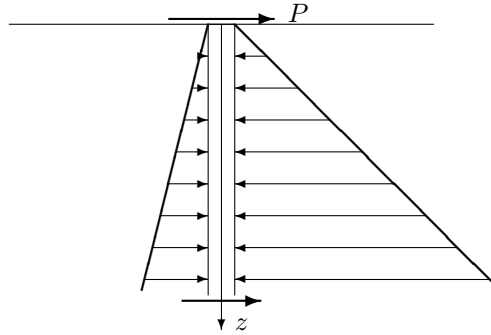

Figure 8.5: Soil reaction according to Blum.

The value of the parameter h , which is the level at which the pile is considered to be clamped, is unknown. A possible reasoning leading to the last three conditions is that the pile is very well clamped at great depths, so that the displacement u and its first two derivatives are zero there. The weak point in this argument, at least from the mathematical side, is that at the depth $z = h$ the third derivative cannot be zero, because the concentrated force is acting there. It may also be noted that the assumed soil reaction cannot be in equilibrium with the applied load without the concentrated force, because then equilibrium of moments is impossible. The analysis using the assumptions for the pressure distribution as shown in figure 8.5 is an excellent example of the art of engineering, especially since it will appear later that the results are in excellent agreement with those of more refined models.

The general solution of the differential equation (8.21) is

$$u = -\frac{(K_p - K_a)\gamma'Dz^5}{120 EI} - \frac{2cD(\sqrt{K_p} + \sqrt{K_a})z^4}{24 EI} + C_1z^3 + C_2z^2 + C_3z + C_4. \quad (8.27)$$

Using the boundary conditions the integration constants can be determined. Substitution of these values in the solution (8.27) gives the final solution in the form

$$u = \frac{(K_p - K_a)\gamma'D(8h^2 + 9hz + 3z^2)}{360 EI} (h - z)^3 + \frac{(\sqrt{K_p} + \sqrt{K_a})cD(h + z)}{12 EI} (h - z)^3, \quad (8.28)$$

where the value of h must be determined from the relation

$$P = \frac{1}{6}(K_p - K_a)\gamma'Dh^2 + (\sqrt{K_p} + \sqrt{K_a})cDh. \quad (8.29)$$

If the force P is given, and the properties of soil and pile are known, the value of h can be determined from eq. (8.29). Then the displacement can be obtained from eq. (8.28).

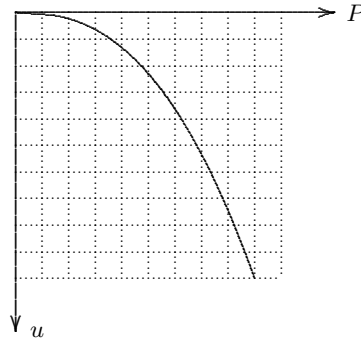

Figure 8.6: Laterally loaded pile in perfectly plastic material.

Figure 8.6 shows the relation between the lateral force P and the displacement of the top of the pile u_t in graphical form, for the case of a cohesionless soil ($c = 0$). It can be seen that the pile becomes much more flexible when the load increases. This is due to the fact that when a certain level of pile load has been reached, the soil over a certain length near the top of the pile is all in the plastic range, and cannot contribute to the carrying of an additional load. Thus the additional load will have to be balanced by an increase of the plastic range at lower depths, and this gives rise to considerable additional displacements.

When comparing this solution for a perfectly plastic material with the elastic solution of the previous section it may be noted that here the most important parameters for the response characteristic are the pile stiffness EI and the soil strength, as expressed by the parameters $(K_p - K_a)$ and $c(\sqrt{K_p} + \sqrt{K_a})$. The soil stiffness no longer appears in the solution because it has been eliminated from the model by assuming a perfectly plastic response. At this stage it is a matter of conjecture, or of engineering intuition, to prefer one of the two models in favour of the other one.

8.3 Numerical model

In this section a numerical model for the analysis of lateral displacements of a pile loaded by a lateral force at its top is presented. Special care will be taken to ensure that the model can be used for a pile in a layered soil.

8.3.1 Basic equations

In order to develop the numerical model the pile is subdivided into n small elements. A typical element, located between the points z_{i-1} and z_i is shown in figure 8.7. The points are numbered $i = 0, 1, \dots, n$, and the elements are numbered $i = 1, 2, \dots, n$. The pile element may be loaded

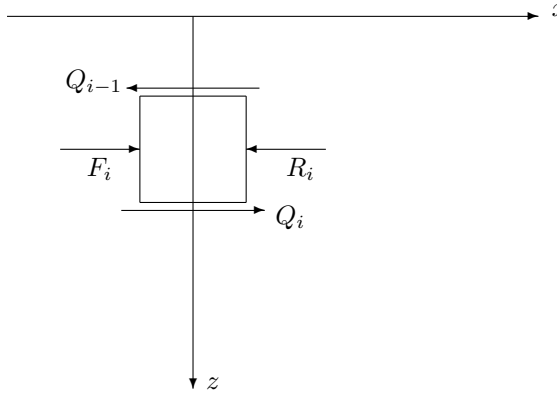

Figure 8.7: Element of laterally loaded pile.

by a given force F_i and by a soil reaction R_i which depends upon the lateral displacements u_{i-1} and u_i .

The basic equations can be established by considering the horizontal equilibrium and the moment equilibrium of the elements i and $i + 1$. The aim of this analysis is to obtain an equation expressing the bending moments into the lateral loads. Equilibrium of the horizontal forces acting upon element i requires that

$$Q_i - Q_{i-1} + F_i - R_i = 0. \quad (8.30)$$

Similarly for the next element horizontal equilibrium requires that

$$Q_{i+1} - Q_i + F_{i+1} - R_{i+1} = 0. \quad (8.31)$$

Addition of these two equations gives

$$Q_{i+1} - Q_{i-1} + F_i + F_{i+1} - R_i - R_{i+1} = 0. \quad (8.32)$$

The equations of equilibrium of moments for the elements i and $i + 1$ are

$$M_i - M_{i-1} = (Q_i + Q_{i-1}) \frac{d_i}{2}, \quad (8.33)$$

and

$$M_{i+1} - M_i = (Q_{i+1} + Q_i) \frac{d_{i+1}}{2}. \quad (8.34)$$

From these two equations one may obtain

$$a_{i+1}M_{i+1} + a_iM_i + a_{i-1}M_{i-1} = \frac{1}{2}(Q_{i+1} - Q_{i-1}), \quad (8.35)$$

where

$$\begin{aligned} a_{i+1} &= \frac{1}{d_{i+1}}, \\ a_i &= -\frac{1}{d_{i+1}} - \frac{1}{d_i}, \\ a_{i-1} &= \frac{1}{d_i}. \end{aligned} \quad (8.36)$$

The shear forces can now be eliminated from eqs. (8.32) and (8.35). This gives

$$a_{i+1}M_{i+1} + a_iM_i + a_{i-1}M_{i-1} = \frac{1}{2}(-F_{i+1} - F_i + R_{i+1} + R_i). \quad (8.37)$$

This is the numerical equivalent of the basic differential equation

$$\frac{d^2M}{dz^2} = -f. \quad (8.38)$$

When all the elements have the same length the finite difference molecule reduces to the familiar combination (1,-2,1). The derivation given above applies equally well when the elements have variable lengths, however.

In order to derive the numerical equivalent of the bending equation

$$\frac{d^2u}{dz^2} = -\frac{M}{EI}, \quad (8.39)$$

for the case of non-equal intervals, the following approximations are introduced for the lateral displacements in elements i and $i + 1$,

$$z_{i-1} < z < z_i : \quad u = u_i + \phi_i z + \frac{1}{2}\kappa_i z^2, \quad (8.40)$$

and

$$z_i < z < z_{i+1} : \quad u = u_i + \phi_i z + \frac{1}{2}\kappa_{i+1} z^2. \quad (8.41)$$

This ensures that the displacement u and its first derivative ϕ are continuous at the point $z = z_i$. The curvatures in elements i and $i + 1$ may be different, however. They are denoted by κ_i and κ_{i+1} .

It follows from equations (8.40) and (8.41) that

$$u_{i-1} = u_i - \phi_i d_i + \frac{1}{2}\kappa_i d_i^2, \quad (8.42)$$

and

$$u_{i+1} = u_i + \phi_i d_{i+1} + \frac{1}{2}\kappa_{i+1} d_{i+1}^2. \quad (8.43)$$

From these two equations the slope ϕ_i can be eliminated,

$$\frac{u_{i+1} - u_i}{d_{i+1}} + \frac{u_{i-1} - u_i}{d_i} = \frac{1}{2}\kappa_{i+1} d_{i+1} + \frac{1}{2}\kappa_i d_i. \quad (8.44)$$

The curvatures κ_i and κ_{i+1} may be related to the average bending moments in the elements i and $i + 1$, respectively,

$$\kappa_i = -\frac{M_i + M_{i-1}}{2EI_i}, \quad (8.45)$$

and

$$\kappa_{i+1} = -\frac{M_{i+1} + M_i}{2EI_{i+1}}. \quad (8.46)$$

It now follows from eqs. (8.44), (8.45) and (8.46) that

$$a_{i+1}u_{i+1} + a_i u_i + a_{i-1}u_{i-1} = -b_{i+1}M_{i+1} - b_i M_i - b_{i-1}M_{i-1}, \quad (8.47)$$

where the coefficients a_i are the same as before, see (8.37), and where

$$\begin{aligned} b_{i+1} &= \frac{d_{i+1}}{4EI_{i+1}}, \\ b_i &= -\frac{d_{i+1}}{4EI_{i+1}} - \frac{d_i}{4EI_i}, \\ b_{i-1} &= \frac{d_i}{4EI_i}. \end{aligned} \quad (8.48)$$

Equation (8.47) is the numerical equivalent of eq. (8.39). The derivation given here appears to lead to the same type of equation as for the equilibrium equation (8.37). The two equations (8.37) and (8.47) are the two basic equations of the numerical model. The variables in the model are the displacements u_i and the moments M_i for $i = 0, 1, \dots, n$. These are $2(n + 1)$ variables, for which the model gives $2(n - 1)$ equations (for $i = 1, 2, \dots, n - 1$). The 4 remaining equations must be derived from the boundary conditions. It should be noted that the soil reactions R_i must be related to the lateral displacements. In general this will be a non-linear relation.

8.3.2 Pile-soil interaction

The reaction of the soil is supposed to be elasto-plastic, as illustrated in figure 8.8. This figure represents the soil reaction from the soil to the

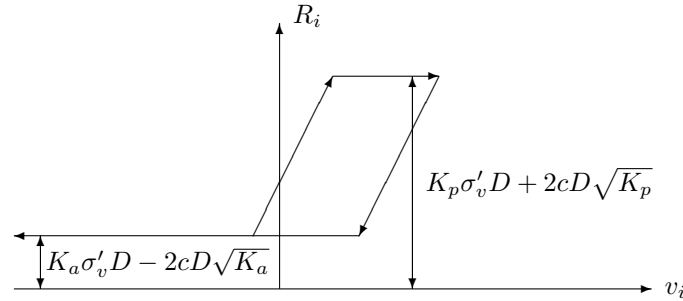

Figure 8.8: Elasto-plastic soil response, right side.

right of the pile, assuming that the positive x -direction is towards the right. In general the soil response may be written as

$$R_i = S_i(v_i - \bar{v}_i) + T_i, \quad (8.49)$$

where v_i is the displacement of element i , which may be related to the displacements of the nodes by

$$v_i = \frac{1}{2}(u_i + u_{i-1}). \quad (8.50)$$

In eq. (8.49) \bar{v}_i is the accumulated plastic displacement, which must be updated during the deformation process. The coefficient S_i represents the slope of the response curve, which is zero in the plastic branches. The term T_i is zero in the elastic branch, and may be used to represent the plastic soil response in the plastic branches.

It should be noted that there is also a response on the other side of the pile. This is of the same type as the response on the right side, except for the sign, see figure 8.9. Initially, for very small displacements, the two responses will both be in the elastic range, and this simply means that the stiffnesses can be added. After plastic deformations have occurred, however, the response becomes more complicated, because the transition from the elastic to the plastic branches is shifted when the plastic deformation accumulates. The description of the pile-soil interaction can most conveniently be implemented by considering the response from the two sides of the pile separately.

The resultant response of the two sides, for the first loading of a pile, is as shown in figure 8.10. The initial response is that both on the left and the right side of the pile the springs are in the elastic range. As soon as the first spring reaches the plasticity limit, the stiffness is

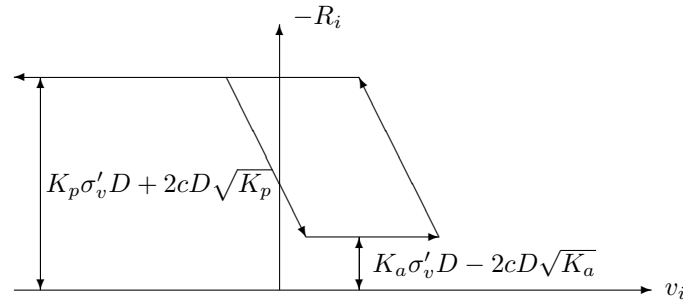

Figure 8.9: Elasto-plastic soil response, left side.

reduced, and finally reduced to zero when the other spring reaches its plasticity limit. It is interesting to note that a tri-linear curve as shown in figure 8.10 is given by the American Petroleum Institute in its recommendations for planning, design and constructing fixed offshore platforms (API, 1981). The main advantage of the more basic response built up from the two responses on either side of the pile is that in this way it is conceptually easier to describe the behaviour in unloading and subsequent reloading.

8.3.3 Boundary conditions

It is most convenient if the boundary conditions can be expressed as conditions for the displacement and the bending moment at the pile top and pile tip, respectively. The physically most realistic boundary condition, however, is that the shear force and the moment are given at a free end of the pile. The prescribed moment can easily be incorporated in the system of equations, but it requires some effort to transform the condition of a prescribed shear force into a condition in terms of the displacement. As an example the boundary condition at the pile top will be considered. Let this condition be

$$z = 0 : \quad Q_0 = -P. \quad (8.51)$$

Equilibrium of moments of the first element expresses that

$$M_1 - M_0 = (Q_1 + Q_0) \frac{d_1}{2}. \quad (8.52)$$

The shear force Q_1 may be eliminated by considering horizontal equilibrium of this element,

$$Q_1 - Q_0 = -F_1 + R_1. \quad (8.53)$$

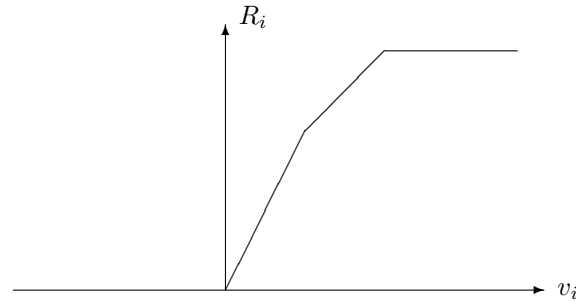

Figure 8.10: Resultant soil response.

Thus, with $Q_0 = -P$ one obtains

$$R_1 + \frac{2}{d_1}(M_1 - M_0) = F_1 + 2P. \quad (8.54)$$

Because the soil reaction R_1 will depend upon the lateral displacements u_0 and u_1 this can be considered as an equation formulated in terms of the displacement u_0 . It should be noted that the dependence upon u_0 may vanish if the first element is in the plastic range. Mathematically, this means that the coefficient on the main diagonal of the system of equations representing the coefficient of u_0 may vanish. The solution technique to be used for solving the system of equations should best be such that division by this coefficient is avoided. This may be achieved by eliminating the variables from $i = n$ down to $i = 0$.

8.3.4 Computer program

An elementary computer program, in Turbo Pascal, is reproduced below, as program LLP. The program applies only to a homogeneous soil and pile, although many facilities have been built in which may facilitate generalization of the program to the more general case of a pile in a layered soil. The program uses interactive input, with all data to be entered by the user after being prompted by the program. This includes the number of loading steps, which enables to analyze problems with a variable load. Output is given in the form of the displacement of the top for a given value of the force and the moment applied at the top of the pile. The program can easily be modified to give graphical output, or output on a printer.

```
program llp;
uses crt;
const
```

```

maxel=100;maxwid=4;maxit=100;
var
len,wid,wht,act,pas,neu,coh,stk,ei,ft,dz,cp,fa,ma:real;
step,nel,steps,ll,lp,nerr,mp,mq,plast,it:integer;
z,s,d,f,u,q,ul,ur,m,ff:array[0..maxel] of real;
as,ps,sl,pa,pp,pn:array[1..maxel] of real;
p:array[0..maxel,1..maxwid,1..2,1..2] of real;
kk:array[0..maxel,1..maxwid] of integer;
g:array[1..2,1..2] of real;
np,nq:array[0..maxel] of integer;
fs,wt:array[0..100] of real;data:text;
procedure title;
begin
  clrscr;gotoxy(38,1);textbackground(7);textcolor(0);write(' LLP ');
  textbackground(0);textcolor(7);writeln;writeln;
end;
procedure next;
var
  a:char;
begin
  gotoxy(25,25);textbackground(7);textcolor(0);
  write(' Touch any key to continue ');write(chr(8));
  a:=readkey;textbackground(0);textcolor(7)
end;
procedure input;
var
  i:integer;
begin
  title;
  write('This is a program for the analysis of a laterally loaded');
  writeln(' pile.');

```

```

if act>1 then act:=1;if pas<1 then pas:=1;
if neu<act then neu:=act;
if neu>pas then neu:=pas;
ft:=0;dz:=len/nel;z[0]:=0;
for i:=1 to nel do begin z[i]:=z[i-1]+dz;d[i]:=dz;end;
for i:=0 to nel do
  begin
    u[i]:=0.0;m[i]:=0.0;ul[i]:=0.0;ur[i]:=0.0;
  end;
end;
procedure zeros;
var
  i:integer;
begin
  for i:=1 to nel do begin np[i]:=0;nq[i]:=0;end;
end;
procedure constants;
var
  i:integer;
  sz,e:real;
begin
  for i:=1 to nel do
    begin
      e:=0.000001;sz:=wht*wid*(z[i]-d[i]/2);
      pa[i]:=act*sz-2*coh*sqrt(act);if pa[i]<0 then pa[i]:=0;
      pn[i]:=neu*sz;pp[i]:=pas*sz+2*coh*sqrt(pas);
      if pp[i]<pa[i]+e then pp[i]:=pa[i]+e;
      as[i]:=(pn[i]-pa[i])*stk/(pp[i]-pa[i]);
      ps[i]:=(pp[i]-pn[i])*stk/(pp[i]-pa[i]);
      sl[i]:=(pp[i]-pa[i])/stk;
    end;
  end;
end;
procedure springs;
var
  i,nr:integer;
  um,sp,eps,sx:real;
begin
  nerr:=0;plast:=0;eps:=0.000001;
  for i:=1 to nel do
    begin
      um:=(u[i]+u[i-1])/2;if um-ul[i]>as[i]+eps then
        begin
          sx:=pa[i];sp:=0;nr:=1;plast:=plast+1;
        end;
    end;
  end;
end;

```

```

    end
else if um-ul[i]<-ps[i]-eps then
begin
    sx:=pp[i];sp:=0;nr:=-1;plast:=plast+1;
end
else
begin
    sp:=sl[i];sx:=pn[i]+sp*ul[i];nr:=0;
end;
f[i]:=sx*d[i];s[i]:=sp*d[i];
if np[i]<>nr then
begin
    np[i]:=nr;nerr:=nerr+1;
end;
if um-ur[i]<-as[i]-eps then
begin
    sx:=pa[i];sp:=0;nr:=1;plast:=plast+1;
end
else if um-ur[i]>ps[i]+eps then
begin
    sx:=pp[i];sp:=0;nr:=-1;plast:=plast+1;
end
else
begin
    sp:=sl[i];sx:=pn[i]-sp*ur[i];nr:=0;
end;
f[i]:=f[i]-sx*d[i];s[i]:=s[i]+sp*d[i];
if nq[i]<>nr then
begin
    nq[i]:=nr;nerr:=nerr+1;
end;
end;
end;
procedure matrix;
var
    i,j,h,k,l:integer;a1,a2,b1,b2,c1:real;
begin
    h:=maxwid;
    for i:=0 to nel do for j:=1 to maxwid do
begin
    kk[i,j]:=0;
    for k:=1 to 2 do for l:=1 to 2 do p[i,j,k,l]:=0;
end;
end;

```

```

for i:=1 to nel-1 do
  begin
    kk[i,1]:=i;kk[i,2]:=i-1;kk[i,3]:=i+1;kk[i,h]:=3;
  end;
kk[0,1]:=0;kk[0,2]:=1;kk[0,h]:=2;
kk[nel,1]:=nel;kk[nel,2]:=nel-1;kk[nel,h]:=2;
for i:=1 to nel-1 do
  begin
    a1:=1.0/d[i+1];a2:=1.0/d[i];
    p[i,1,1,1]:=-a1-a2;p[i,2,1,1]:=a2;p[i,3,1,1]:=a1;
    p[i,1,1,2]:=-(s[i]+s[i+1])/4.0;p[i,2,1,2]:=-s[i]/4.0;
    p[i,3,1,2]:=-s[i+1]/4.0;
    p[i,h,1,1]:=-(f[i]+f[i+1])/2.0;
    p[i,1,2,2]:=-a1-a2;p[i,2,2,2]:=a2;p[i,3,2,2]:=a1;
    p[i,1,2,1]:=(d[i]+d[i+1])/(4.0*ei);
    p[i,2,2,1]:=d[i]/(4.0*ei);p[i,3,2,1]:=d[i+1]/(4.0*ei);
  end;
p[0,1,1,1]:=1.0;p[0,h,1,1]:=ma;
p[0,1,2,2]:=s[1]/4.0;p[0,2,2,2]:=s[1]/4.0;
p[0,1,2,1]:=1.0/d[1];p[0,2,2,1]:=-1.0/d[1];
p[0,h,2,2]:=f[1]/2.0+fa;p[nel,1,1,1]:=1.0;
p[nel,1,2,2]:=s[nel]/4.0;p[nel,2,2,2]:=s[nel]/4.0;
p[nel,1,2,1]:=1.0/d[nel];p[nel,2,2,1]:=-1.0/d[nel];
p[nel,h,2,2]:=f[nel]/2.0;
end;
procedure solve;
var
  i,j,h,k,l,ii,ij,ik,jj,jk,jl,jv,kc,kv,lv: integer;
  cc,aa: real;
begin
  h:=maxwid;
  for i:=nel downto 0 do
    begin
      kc:=kk[i,h];for kv:=1 to 2 do
        begin
          if p[i,1,kv,kv]=0.0 then
            begin
              writeln('Error : no equilibrium possible');halt;
            end;
          cc:=1.0/p[i,1,kv,kv];
          for ii:=1 to kc do for lv:=1 to 2 do
            begin
              p[i,ii,kv,lv]:=cc*p[i,ii,kv,lv];
            end;
          end;
        end;
      end;
    end;
  end;

```

```

end;
p[i,h,kv,kv]:=cc*p[i,h,kv,kv];
for lv:=1 to 2 do if (lv<>kv) then
begin
cc:=p[i,1,lv,kv];
for ii:=1 to kc do for ij:=1 to 2 do
begin
p[i,ii,lv,ij]:=p[i,ii,lv,ij]-cc*p[i,ii,kv,ij];
end;
p[i,h,lv,lv]:=p[i,h,lv,lv]-cc*p[i,h,kv,kv];
end;
end;
if kc>1 then
begin
for j:=2 to kc do
begin
jj:=kk[i,j];l:=kk[jj,h];jk:=1;
for jl:=2 to 1 do begin if kk[jj,jl]=i then jk:=jl;end;
for kv:=1 to 2 do for lv:=1 to 2 do g[kv,lv]:=p[jj,jk,kv,lv];
kk[jj,jk]:=kk[jj,1];kk[jj,l]:=0;
for kv:=1 to 2 do for lv:=1 to 2 do
begin
p[jj,jk,kv,lv]:=p[jj,l,kv,lv];p[jj,l,kv,lv]:=0;
p[jj,h,lv,lv]:=p[jj,h,lv,lv]-g[lv,kv]*p[i,h,kv,kv];
end;
l:=l-1;kk[jj,h]:=1;
for ii:=2 to kc do
begin
ij:=0;
for ik:=1 to 1 do
begin
if kk[jj,ik]=kk[i,ii] then ij:=ik;
end;
if ij=0 then
begin
l:=l+1;ij:=1;kk[jj,h]:=1;kk[jj,ij]:=kk[i,ii];
end;
for kv:=1 to 2 do for lv:=1 to 2 do for jv:=1 to 2 do
p[jj,ij,kv,lv]:=p[jj,ij,kv,lv]-g[kv,jv]*p[i,ii,jv,lv];
end;
end;
end;
end;
end;
end;
end;
end;

```

```

for j:=0 to nel do
begin
  l:=kk[j,h];if l>1 then
  begin
    for k:=2 to l do
    begin
      jj:=kk[j,k];
      for kv:=1 to 2 do for lv:=1 to 2 do
        p[j,h,kv,kv]:=p[j,h,kv,lv]-p[j,k,kv,lv]*p[jj,h,lv,lv];
      end;
    end;
  end;
end;
for i:=0 to nel do
begin
  m[i]:=p[i,h,1,1];u[i]:=p[i,h,2,2];
end;
q[0]:=-fa;ff[0]:=0;for i:=1 to nel do
begin
  aa:=(m[i]-m[i-1])/d[i];
  q[i]:=-q[i-1]+2*aa;ff[i]:=(q[i-1]-q[i])/d[i];
end;
end;
procedure update;
var
  i:integer;aa:real;
begin
  for i:=1 to nel do
  begin
    aa:=(u[i]+u[i-1])/2-ul[i];
    if aa>=as[i] then ul[i]:=(u[i]+u[i-1])/2-as[i];
    if aa<=-ps[i] then ul[i]:=(u[i]+u[i-1])/2+ps[i];
    aa:=(u[i]+u[i-1])/2-ur[i];
    if aa<=-as[i] then ur[i]:=(u[i]+u[i-1])/2+as[i];
    if aa>=ps[i] then ur[i]:=(u[i]+u[i-1])/2-ps[i];
  end;
end;
begin
input;constants;zeros;
for step:=1 to steps do
begin
  title;it:=0;writeln('Loading step ',step);writeln;
  write('Force at the top (kN) ..... ');readln(fa);writeln;
  write('Moment at the top (kNm) ..... ');readln(ma);writeln;

```

```

springs;
repeat
  matrix;solve;springs;
  if plast<2*nrel then begin writeln('Pile failed');nerr:=0;end;
  it:=it+1;if it=maxit then
    begin
      writeln('Warning : no convergence ');writeln;nerr:=0;
    end;
until nerr=0;
if plast<2*nrel then
  begin
    writeln('Displacement at the top (m) ..... ',u[0]:8:6);
    writeln;
    writeln('Number of plastic springs ..... ',plast);
    next;update;
  end
else step:=steps;
end;
title;
end.

```

Program LLP.

In this program the variables $np[i]$ and $nq[i]$ are used to indicate the branch of the response curve for the springs on the left side and the right side of the pile, respectively. A value 0 indicates the elastic branch, a value +1 indicates an active state of stress in the soil, and a value -1 indicates a passive state of stress in the soil. All values are initially estimated as zero, and then corrected in an iterative way, until all predictions agree with the values obtained after solving the system of equations. It may be noted that in checking the springs a small error ($\epsilon = 0.000001$) is tolerated. This is introduced to avoid repeated iterations around a corner point in the stress-strain curve. An essential part of the program is the procedure "update", in which the accumulated plastic deformations are updated for the latest loading step.

As an application of the program an example has been elaborated. This example applies to a steel tubular pile of 50 m length, with a diameter of 1 m, and a wall thickness of 0.05 m, so that the bending stiffness of the pile EI is 4123000 kNm². The active soil pressure coefficient has been taken as 0.333, the passive coefficient as 3.0, and the neutral coefficient as 0.5. The cohesion has been assumed to be zero, indicating a sandy soil. The (submerged) weight of the soil has been assumed to be 10 kN/m³, and the stroke has been taken as 0.01 m. The pile is loaded by a force which gradually increases from zero to 1000 kN, is then reduced to zero, with two subsequent reloading cycles up to 1000 kN. The load-displacement curve is shown in figure 8.11. The displacement corresponding to the full load is about 0.12 m. As this is far beyond the value of the stroke, it can readily be understood that during unloading plastic deformations occur again, as can be seen from the figure. It also appears that there is a considerable hysteretic damping in each cycle.

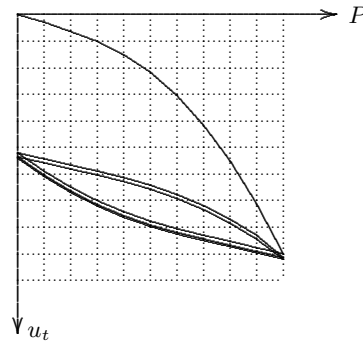

Figure 8.11: Example of laterally loaded pile.

8.3.5 Advanced computer program

An advanced computer program, LLP99, is distributed by the Geotechnical Laboratory of the Delft University of Technology. This program is applicable to a pile in a layered soil (maximum 20 layers), where in each layer the pile and soil parameters may be different. Input parameters are generated interactively, with the user responding to prompts from the program, and then stored in a datafile. The program calculates the displacements due to a stepwise varying lateral load and a variable moment applied at the top of the pile. Output data are presented on the screen, in tabular form, and in graphical form, and then stored in the datafile. The data from this datafile may be used for later presentation of the output data.

8.4 Cyclic lateral loading

Damping of energy in laterally loaded piles is an important physical phenomenon, which is for instance used to great advantage in guard rails along motorways. During a crash large amounts of energy are absorbed in the plastic deformation of the soil. As the soil retains its friction, the barrier can easily be restored to its original form and function.

This hysteretic damping of energy is also of great importance for the behaviour in cyclic loading of large structures founded on piles. It is essential for this type of damping that it is generated by dry friction, and is independent of the velocity. This property is in sharp contrast with viscous damping, as produced by the behaviour of a fluid, for instance in a dashpot, which is proportional to the velocity. The effect of a viscous damper is very large when the frequency of the vibrations is very high, and its influence practically vanishes when the load is applied very slowly. This is not the case for a hysteretic, or plastic, damper. Here the effect is mainly determined by the magnitude of the applied load, and not by the loading rate. It will appear later, however, that it may be possible to compare the two types of behaviour, and to determine an

equivalent viscosity for the pile-soil system, at least for certain forms of loading.

In order to further illustrate the effect of hysteretic damping occurring in a laterally loaded pile, a pile is considered loaded by a cyclic load, varying between +1000 kN and -1000 kN, see figure 8.12. All properties of the soil and pile are the same as those for the example in the

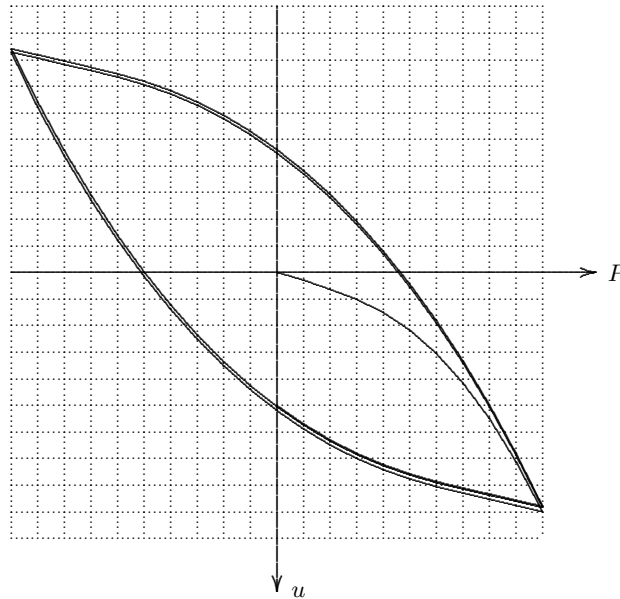

Figure 8.12: Damping in laterally loaded pile.

previous section. The pile length is 50 m, its width is 1 m, and its wall thickness is 0.05 m. The submerged unit weight of the soil is 10 kN/m^3 , the active pressure coefficient is 0.333, the passive pressure coefficient is 3.0, the neutral pressure coefficient is 0.5, the cohesion is zero, and the stroke is 0.01 m. The response of the pile-soil system has been calculated using the numerical program LLP, see figure 8.12, which shows the response in three full cycles of loading.

It appears from figure 8.12 that there is very little difference between the behaviour in the various cycles, except in the first one, during which some additional deformations occur. It seems that in the first loading step an initial state of stress is created, and that thereafter the pile behaviour is independent of the cycle number. This type of behaviour is known as *shakedown* in plasticity theory. The displacement of the pile top varies between +0.12 m and -0.12 m in each cycle.

8.4.1 Influence of soil parameters

In general a numerical model has the disadvantage that it is not immediately clear in what way the various parameters influence the results. For this purpose a parameter study has to be performed, in which each parameter is varied independently. In order to investigate the influence of the various parameters on the damping of a laterally loaded pile, the problem considered above will be taken as a reference case, and various parameters will be varied.

First the soil stiffness has been varied, by taking three values for the stroke : 0.001 m, 0.01 m, and 0.1 m, keeping all other parameters constant. The results of the numerical calculations, using the program LLP, are shown in figure 8.13. The fully drawn curve corresponds to the reference case, with a stroke of 0.01 m. The dashed curve is for the 10 times stiffer soil, with a stroke of 0.001 m, and the dotted curve is for the 10 times softer soil, having a stroke of 0.1 m.

It can be seen from figure 8.13 that in general the influence of the soil stiffness is small. A noticeable influence can only be produced by making the soil 10 times softer, which results in an unrealistically large value for the stroke. Making the soil stiffer than the standard value has hardly any effect. The explanation is that the applied force is large enough for the soil to reach the plastic domain, at least near the top of the pile, and that the deformation of the pile mainly depends upon the stresses in this top part, and on the stiffness of the pile itself. The results also suggest that perhaps the approximate solution based upon Blum's assumption, which was presented in an earlier section, can be used as a valuable reference. This approximation can be considered to be based on the assumption that the stroke is zero, which means that the soil stiffness is infinitely large, but of course restricted to a certain domain, limited by active and passive soil pressures.

It is recalled, from eq. (8.28), that the approximate solution is, for a cohesionless soil,

$$u = \frac{(K_p - K_a)\gamma' Dh^5}{45 EI}, \quad (8.55)$$

where the value of h must be determined from the relation

$$P = \frac{(K_p - K_a)\gamma' Dh^2}{6}. \quad (8.56)$$

In order to test the hypothesis that this approximation may describe the behaviour of the pile-soil system with reasonable accuracy, the maximum displacements may first be compared. These maximum displacements, corresponding to a force of 1000 kN, are listed in table 8.1. The value recorded for a zero stroke has been obtained from the approximate formula, the others have been determined using the numerical model. It appears that the displacements are indeed very close, except for very large values of the stroke, that is for extremely soft soils. Such large values of the stroke seem to be unrealistic, and it may thus be concluded that the approximate formula indeed gives a reasonable prediction of the maximum displacements at full loading.

Cyclic load

The approximate formula only applies to a gradually increasing load, and as such does not give the possibility to study the response to a cyclic load. In order to apply the formula also for cyclic loading conditions, however, it may be assumed that the formula is used to predict the

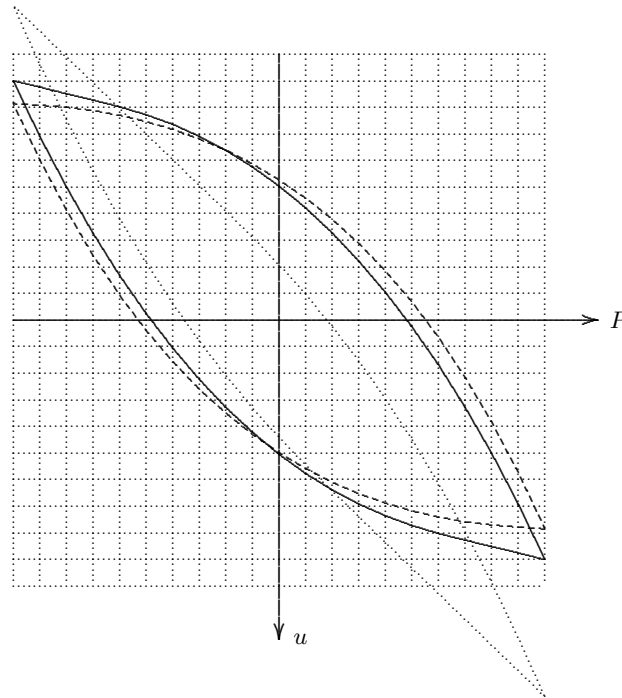

Figure 8.13: Influence of soil stiffness.

amplitude of the response curve, and that the shape of the response curve is simply obtained by considering the formula as a type curve. This means that the behaviour in each loading cycle is taken such that the displacement in each branch of the response curve is proportional to the load applied in that branch to the power $\frac{5}{2}$, with the actual numerical values determined such that the amplitude is obtained from the formula (8.55). Figure 8.14 shows a comparison of the response obtained from the numerical model, using a value of 0.001 m for the stroke, with the response obtained from the adapted approximate model, the dotted line in the figure. It appears that the approximation is fairly good. Again the approximate formula appears to represent the case of a very small stroke, that is a stiff soil, with sufficient accuracy.

The influence of the soil strength on the cyclic response can be expected to be much larger than the influence of the soil stiffness. This can also be seen from the approximate formula, in which the soil strength dominates the behaviour. Actually, in this formula, see eqs. (8.55) and (8.56), the strength parameter $(K_p - K_a)$ appears such that the displacements are proportional to the factor $(K_p - K_a)^{-3/2}$. The hypothesis

stroke (m)	u_{max} (m)
0.100	0.188
0.010	0.120
0.001	0.105
0.000	0.109

Table 8.1: Maximum displacements.

that formula (8.55) is a reasonable approximation can be tested once more by plotting the displacements using the predicted proportionality factor $(K_p - K_a)^{-3/2}$ as a scaling factor. The results of the numerical calculations plotted in this way are shown in figure 8.15, for 3 values of the passive soil pressure coefficient : $K_p = 1.5, 3, 6$, and using the relation $K_a = 1/K_p$ to calculate the active soil pressure coefficient in each case. The full line has been obtained using $K_p = 3$ (the reference value), the dotted line is for $K_p = 6$, and the dashed line is for $K_p = 1.5$. It appears that the agreement is again rather good, and that the shape of the curve in general agrees fairly well with that of the type curve obtained from the approximate solution (the dotted curve in figure 8.14).

The general conclusion of all these comparisons can be that the approximate formula (8.28), in which the soil behaviour is characterized by the strength only, and in which the soil stiffness does not appear, gives a fairly reasonable representation of the behaviour of a laterally loaded pile, provided that the lateral load is large, and the soil is stiff.

8.4.2 Equivalent spring and dashpot

The availability of an approximate formula, eq. (8.55), for the relation between the force and the displacement enables to evaluate the energy dissipated in a full cycle of loading. Actually, one may write for the work done in loading from $-P_m$ to P_m ,

$$W_1 = \int_0^{2P_m} P du = \int_0^{2P_m} P \frac{du}{dh} dh. \quad (8.57)$$

With (8.55) and (8.56) this gives

$$W_1 = \frac{20}{7} P_{max} u_{max}. \quad (8.58)$$

In the unloading branch of the cycle the work done is

$$W_2 = -\frac{8}{7} P_{max} u_{max}, \quad (8.59)$$

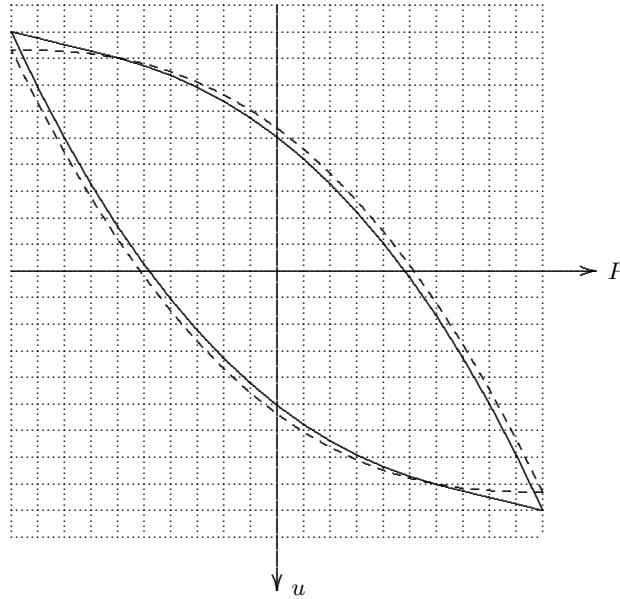

Figure 8.14: Comparison with approximate solution.

the complement of the full value obtained by multiplying the total load $2P_m$ and the total displacement $2u_m$. Thus the total work done in a full cycle is

$$W = \frac{12}{7} P_{max} u_{max}. \quad (8.60)$$

It is interesting to compare this result with the one obtained for a simple system of a spring and a dashpot, in which the damping is of a viscous character, see figure 8.16. If the spring constant is k and the viscosity of the damper is c the equation of motion for such a system is

$$c \frac{du}{dt} + ku = P(t), \quad (8.61)$$

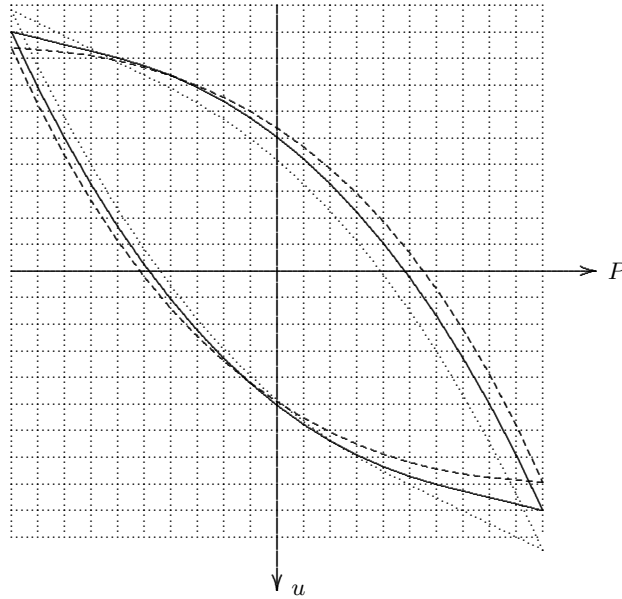

Figure 8.15: Influence of soil strength.

where $P(t)$ is the applied force. For a cyclic load, $P = P_{max} \sin(\omega t)$ the response is

$$u = u_{max} \sin(\omega t - \psi), \quad (8.62)$$

where

$$u_{max} = \frac{P_{max}}{\sqrt{k^2 + c^2\omega^2}}, \quad (8.63)$$

and

$$\tan \psi = \frac{c\omega}{k}. \quad (8.64)$$



Figure 8.16: Spring and dashpot.

The response of the system is shown graphically in figure 8.17. Although the shape of the response curve is quite different from the one for an elasto-plastic system, the general behaviour may well be compared. Actually, the energy dissipated during a full cycle in this case is

$$W = \pi P_{max} u_{max} \sin(\psi). \quad (8.65)$$

Comparing this with (8.60) shows that the two expressions are equivalent if

$$\pi \sin(\psi) = \frac{12}{7}. \quad (8.66)$$

It now follows that $\sin(\psi) = 0.54567$, and thus $\psi = 33^\circ$, and $\tan(\psi) = 0.65$. This means that the behaviour of a laterally loaded pile can be simulated by a system of a spring and a dashpot, provided that the viscosity c is taken as

$$c = 0.65 \frac{k}{\omega}. \quad (8.67)$$

Here ω is the frequency of the load, which is assumed to be known. The equivalent spring constant k is defined as

$$k = 0.84 \frac{P_{max}}{u_{max}}, \quad (8.68)$$

where the factor 0.84 is obtained when the value $c\omega/k = 0.65$ is substituted into eq. (8.63).

In practical applications the maximum load can be considered to be known, at least approximately. The corresponding maximum displacement can then be determined from a non-linear analysis, using the approximate solution (8.55), or, better still, a numerical analysis. The equivalent viscosity can then be estimated from (8.67). A better estimate can again be obtained from a complete numerical analysis, and then evaluating the area of the response curve to determine the work done in a full cycle. By comparing this with (8.65) the value of ψ can be determined. Thus the values of an equivalent spring constant and an equivalent viscosity may be obtained. These may then be used as input parameters for a dynamic analysis of the entire structure. If necessary the values of the spring constant and the viscosity may be updated on the basis of the results of the analysis, and the analysis may be repeated using these updated values.

It may be noted that eq. (8.67) states that the equivalent viscosity is inversely proportional to the frequency. Thus for a high frequency (rapid variations) the damping is small, and for a low frequency (slow variations) the damping is high. In this way the resulting response is made independent of the actual frequency, which should indeed be the case for damping generated by elasto-plastic elements.

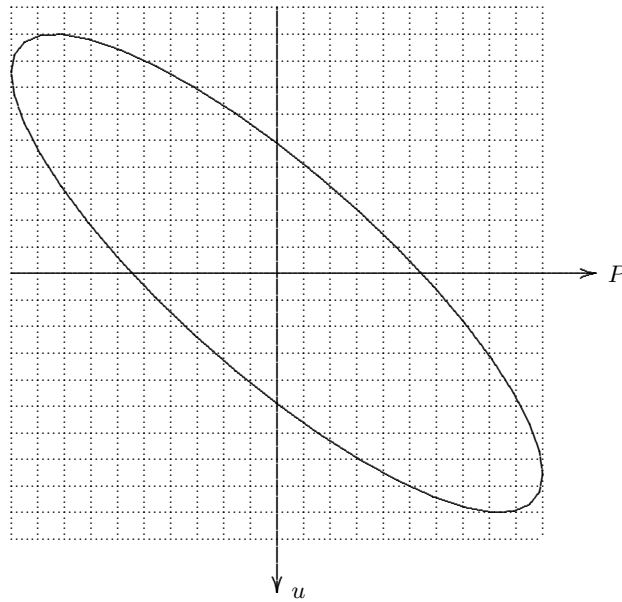

Figure 8.17: Response of spring-dashpot system.

Chapter 9

PILE IN LAYERED ELASTIC MATERIAL

In the models presented above the soil reaction has been represented by a system of non-linear springs. This means that the soil response at a certain depth is assumed to be determined only by the local displacement. Thus, the actual stress transfer in the soil has no influence on the interaction of the soil and the pile. In more refined models the soil is represented by an elastic continuum. Examples of this are the models developed by Poulos (1971), Banerjee & Davis (1978), Randolph (1981) and Verruijt & Kooijman (1989). This latter model, which applies to a laterally loaded pile only, will be presented in this section. Compared to other models it has the advantage that it can be generalized to include plastic deformations of the soil and to the interaction of a pile group with the soil (Kooijman, 1989).

9.1 Elastic model

In the elastic version of the Kooijman model the soil is represented by a system of elastic layers, of constant depth, see figure 9.1. The pile is a

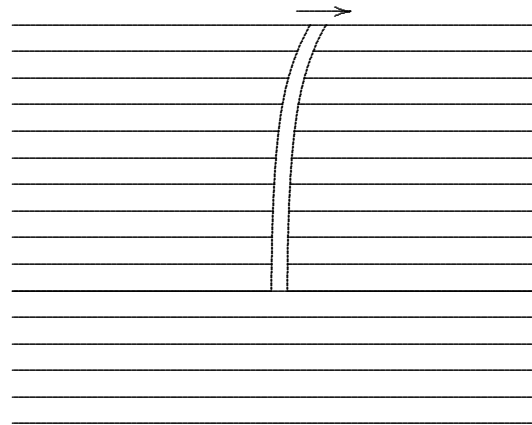

Figure 9.1: Laterally loaded pile in layered elastic material.

cylindrical inclusion in the layers. It is now assumed that in each layer the horizontal loading of the soil by the pile elements produces mainly horizontal deformations. The basic differential equations can now be obtained by averaging the three-dimensional equations of equilibrium in the two horizontal directions over the thickness of a layer, neglecting all terms involving the vertical displacement. This leads to the following equations

$$\frac{\partial \sigma_{xx}}{\partial x} + \frac{\partial \sigma_{yx}}{\partial x} + Q_x = 0, \quad (9.1)$$

$$\frac{\partial \sigma_{xy}}{\partial x} + \frac{\partial \sigma_{yy}}{\partial x} + Q_y = 0, \quad (9.2)$$

where σ_{xx} , σ_{yy} and σ_{xy} are the average stresses in a horizontal layer, and Q_x and Q_y represent the body forces. These body forces are supposed to be generated by the interaction with the layers above and below the layer considered,

$$Q_x = \frac{\sigma_{zx}^+ - \sigma_{zx}^-}{h}, \quad (9.3)$$

$$Q_y = \frac{\sigma_{zy}^+ - \sigma_{zy}^-}{h}, \quad (9.4)$$

where h is the thickness of the layer, and where the superscripts $+$ and $-$ denote the values at the bottom and the top of the layer, respectively.

The shear stresses σ_{zx} and σ_{zy} at the top and the bottom of the i -th layer can be expressed in terms of the shear strains ε_{zx} and ε_{zy} by using Hooke's law. When the vertical displacements are again disregarded, these shear strains can be expressed into the horizontal displacements only. This gives

$$\sigma_{zx} = G \frac{\partial u}{\partial z}, \quad (9.5)$$

$$\sigma_{zy} = G \frac{\partial v}{\partial z}, \quad (9.6)$$

where G is the shear modulus of the soil in the layer considered. The partial derivatives in z -direction can be approximated by finite difference approximations. If a section from the center of layer i to the center of layer $i + 1$ is considered, one may write

$$\frac{\partial u}{\partial z} \approx \frac{u_{i+1} - u_i}{\frac{1}{2}(h_{i+1} + h_i)}, \quad (9.7)$$

$$\frac{\partial v}{\partial z} \approx \frac{v_{i+1} - v_i}{\frac{1}{2}(h_{i+1} + h_i)}. \quad (9.8)$$

The shear stresses must be continuous across the boundary from layer i to layer $i + 1$. If the shear modulus in these two layers is different this requires that

$$G_{i+1} \left(\frac{\partial u}{\partial z} \right)_{i+1} = G_i \left(\frac{\partial u}{\partial z} \right)_i, \quad (9.9)$$

$$G_{i+1} \left(\frac{\partial v}{\partial z} \right)_{i+1} = G_i \left(\frac{\partial v}{\partial z} \right)_i. \quad (9.10)$$

Using some elementary finite difference approximations, in which it is assumed that the displacements in layer i and $i + 1$ are continuous on their interface, and satisfy the conditions (9.9) and (9.10), it can be shown that

$$(\sigma_{zx}^-)_{i+1} = (\sigma_{zx}^+)_{i+1} \approx \frac{u_{i+1} - u_i}{\frac{1}{2}(h_{i+1}/G_{i+1} + h_i/G_i)}, \quad (9.11)$$

$$(\sigma_{zy}^-)_{i+1} = (\sigma_{zy}^+)_{i+1} \approx \frac{v_{i+1} - v_i}{\frac{1}{2}(h_{i+1}/G_{i+1} + h_i/G_i)}, \quad (9.12)$$

The body forces Q_x and Q_y , as expressed by eqs. (9.3) and (9.4), can now be determined if an estimate or an approximation of the horizontal displacements u and v in the various layers is available. This results in equations of the form of a plane stress problem, see eqs. (9.1) and (9.2). Solving these equations will give better estimations for the displacement field. The procedure will be of an iterative character, in which the displacements in each layer will gradually be improved.

The pile itself is considered as a beam supported by the surrounding soil. The basic equations for such a beam are the well known equations for a beam on elastic foundation (Hetenyi, 1946)

$$\frac{d^2 M}{dz^2} = -f + ku, \quad (9.13)$$

$$\frac{d^2 u}{dz^2} = -\frac{M}{EI}, \quad (9.14)$$

in which M is the bending moment in the pile, f is a given lateral load, k is a spring constant, u is the lateral displacement of the pile, and EI is the flexural rigidity of the pile. These equations can be solved numerically by using a finite difference technique. Even if a very small finite difference is used, so that the number of numerical equations becomes very large (say 1000), the system is very well conditioned, with a small band in the matrix. The numerical solution presents no difficulties.

The numerical formulation of the interaction between pile and soil is

$$F_i = \sum K_{ij} u_j, \quad (9.15)$$

where F_i is the force transmitted to the pile in layer i , and u_j is the lateral displacement of layer j at the pile-soil interface. This equation can also be written as

$$F_i = k_i u_i + F_i^*, \quad (9.16)$$

where F_i^* represents the contribution of all layers except layer i . Equation (9.16) is of the form of the right hand side of eq. (9.13), and can thus be used to calculate the deformations of the pile. The coefficients of the matrix K_{ij} can be calculated by a finite element analysis of the layered soil system, with a unit displacement in a single layer.

The final iterative procedure is as follows.

- First the spring constants of all layers are calculated from a series of finite element analyses of the layered soil system, with a unit displacement in one layer, and zero displacement in the others.
- A finite difference analysis of the pile is performed, using the spring constants calculated in step 1, and disregarding the influence of the other layers (i.e. assuming $F_i^* = 0$).
- Using the displacements of the pile-soil interface as boundary conditions, a series of finite element calculations is made, in which the displacement field in each layer is determined.
- From the finite element results a better approximation of the interaction coefficients between the soil and the pile can be determined. The analysis of the pile can now be repeated, etcetera.

The procedure can be stopped if a given accuracy condition is met, or, more simply, after a given number of iterations (say 10).

9.2 Computer program

A program that performs the calculations is printed below, as the program PILAT. Part of the data is read from a datafile MESH.DAT, which must be given by the user. A sample dataset is also printed below. The other data, such as the length, diameter and wall thickness of the pile, must be given interactively by the user. The program applies to a homogeneous tubular pile, of circular cross section. The maximum number of soil layers is 20, 10 layers next to the pile and 10 layers below it. Below these layers the displacements are zero, indicating a stiff base layer. In the finite difference analysis of the pile itself it is subdivided into 80 elements of equal length.

It may be noted that the data of the finite element mesh (as defined in the datafile MESH.DAT) are such that node 1 is the origin of the pile, and node 2 is on the circumference of the pile. All dimensions are scaled by the program such that the correct diameter of the pile is obtained. It has been assumed that the soil properties are such that the deformation field is symmetric with respect to the two axes. This means that only one quarter of the field is needed to represent the soil, together with appropriate boundary conditions which simulate the symmetry. The outer ring of elements has been given a reduced stiffness, in order to simulate the soil outside the mesh, up to infinity.

When all interactive data have been entered by the user the program reads the input data of the mesh from the datafile MESH.DAT, and shows the mesh on the screen. The program will start its calculations if an arbitrary key is pressed. Output data consist of a list of the displacement, the bending moment, the shear force, and the contact pressure, as functions of the depth, along the pile. These are also shown in graphical form on the screen.

```

program pilat;
uses crt,graph;
const
  maxsub=80;maxwid=4;maxband=16;maxnod=37;maxel=54;maxl=20;
var
  length,diam,wall,elast,ei,force,moment,error,dz,dw:real;
  nl,np,nm,ns,maxit,sub,nn,mm,ll,band,it,il,fin:integer;
  z,s,m,q,u,ff:array[0..maxsub] of real;
  p:array[0..maxsub,1..maxwid,1..2,1..2] of real;
  x,y:array[1..maxnod] of real;xt,yt:array[1..maxnod] of integer;
  ux,uy:array[1..maxnod,0..maxl] of real;
  uq,fq,vq,es,ps,gs:array[0..maxl] of real;
  r:array[1..2*maxnod] of real;pp:array[1..2*maxnod,1..maxband] of real;
  nj:array[1..maxel,1..3] of integer;el,pn,bx,by:array[1..maxel] of real;
  kk:array[0..maxsub,1..maxwid] of integer;g:array[1..2,1..2] of real;
  data:text;
procedure title;
begin
  clrscr;gotoxy(37,1);textbackground(7);textcolor(0);write(' PILAT ');
  textbackground(0);textcolor(7);writeln;
end;
procedure next;
var
  a:char;
begin
  gotoxy(25,25);textbackground(7);textcolor(0);
  write(' Touch any key to continue ');write(chr(8));
  a:=readkey;textbackground(0);textcolor(7)
end;
procedure input;
var
  i,j:integer;ro,ri,pi,a,b:real;
begin
  title;writeln;
  writeln('This is a program for the analysis of a laterally loaded');
  writeln('pile in a soil, consisting of elastic layers, with shear');
  writeln('stress transfer between the layers.');

```

```

pi:=3.1415926;ro:=diam/2.0;ri:=ro-wall;
ei:=elast*pi*(ro*ro*ro*ro-ri*ri*ri*ri)/4.0;
write('Soil layers next to pile (max. 10) ... ');readln(nl);
if (nl<2) then nl:=2;if (nl>10) then nl:=10;np:=nl-1;dw:=length/nl;
write('Soil layers below pile (max. 10) ..... ');readln(ns);ns:=ns+1;
if (ns<0) then ns:=0;if (ns>11) then ns:=11;nm:=np+ns;ns:=nm-1;
write('Lateral force (kN) ..... ');readln(force);
write('Moment (kNm) ..... ');readln(moment);
write('Acceptable error ..... ');readln(error);
if (error<0) then error:=0.0;if (error>1) then error:=1;
write('Maximum number of iterations ..... ');readln(maxit);
if (maxit<2) then maxit:=2;if (maxit>100) then maxit:=100;
sub:=nl*round(int(80.0/nl));dz:=length/sub;z[0]:=0;s[0]:=0;
for i:=1 to sub do z[i]:=i*dz;
title;writeln;
writeln('Properties of layers next to pile :');writeln;
for i:=1 to nl do
begin
write('Layer ',i:3,' : Modulus of elasticity (kPa) ... ');readln(es[i]);
write('Layer ',i:3,' : Poisson ratio ..... ');readln(ps[i]);
if (ps[i]<0) then ps[i]:=0;if (ps[i]>0.5) then ps[i]:=0.5;
gs[i]:=es[i]/(2*(1+ps[i]));ps[i]:=ps[i]/(1+ps[i]);
es[i]:=2*gs[i]*(1+ps[i]);
end;
title;writeln;
writeln('Properties of layers below pile :');writeln;
for i:=nl+1 to nm do
begin
write('Layer ',i:3,' : Modulus of elasticity (kPa) ... ');readln(es[i]);
write('Layer ',i:3,' : Poisson ratio ..... ');readln(ps[i]);
if (ps[i]<0) then ps[i]:=0;if (ps[i]>0.5) then ps[i]:=0.5;
gs[i]:=es[i]/(2*(1+ps[i]));ps[i]:=ps[i]/(1+ps[i]);
es[i]:=2*gs[i]*(1+ps[i]);
end;
for i:=1 to nm do
begin
a:=i*dw;b:=a-dw;
for j:=0 to sub do if (z[j]>b) and (z[j]<=a) then s[j]:=es[i]*dz;
end;
end;
procedure pilematrix;
var
i,j,h,k,l:integer;a1,b1,b2,c1:real;

```

```

begin
h:=maxwid;a1:=1/dz;
for i:=0 to sub do for j:=1 to maxwid do
begin
kk[i,j]:=0;
for k:=1 to 2 do for l:=1 to 2 do p[i,j,k,l]:=0;
end;
for i:=1 to sub-1 do
begin
kk[i,1]:=i;kk[i,2]:=i-1;kk[i,3]:=i+1;kk[i,h]:=3;
end;
kk[0,1]:=0;kk[0,2]:=1;kk[0,h]:=2;
kk[sub,1]:=sub;kk[sub,2]:=sub-1;kk[sub,h]:=2;
for i:=1 to sub-1 do
begin
p[i,1,1,1]:=-2*a1;p[i,2,1,1]:=a1;p[i,3,1,1]:=a1;
p[i,1,1,2]:=-(s[i]+s[i+1])/4;p[i,2,1,2]:=-s[i]/4;
p[i,3,1,2]:=-s[i+1]/4;p[i,h,1,1]:=0;p[i,1,2,2]:=-2*a1;
p[i,2,2,2]:=a1;p[i,3,2,2]:=a1;p[i,1,2,1]:=dz/(2*ei);
p[i,2,2,1]:=dz/(4*ei);p[i,3,2,1]:=dz/(4*ei);
end;
p[0,1,1,1]:=1;p[0,1,2,2]:=s[1]/4;p[0,2,2,2]:=s[1]/4;
p[0,1,2,1]:=a1;p[0,2,2,1]:=-a1;
p[0,h,1,1]:=-moment;p[0,h,2,2]:=force;
p[sub,1,1,1]:=1;p[sub,1,2,2]:=s[sub]/4;p[sub,2,2,2]:=s[sub]/4;
p[sub,1,2,1]:=a1;p[sub,2,2,1]:=-a1;p[sub,h,2,2]:=0;
end;
procedure pilesolve;
var
i,j,h,k,l,ii,ij,ik,jj,jk,jl,jv,kc,kv,lv: integer;
cc,aa: real;
begin
h:=maxwid;
for i:=sub downto 0 do
begin
kc:=kk[i,h];for kv:=1 to 2 do
begin
if (p[i,1,kv,kv]=0) then
begin
writeln('Error : no equilibrium possible');halt;
end;
cc:=1.0/p[i,1,kv,kv];
for ii:=1 to kc do for lv:=1 to 2 do

```



```

begin
  p[i,ii,kv,lv]:=cc*p[i,ii,kv,lv];
end;
p[i,h,kv,kv]:=cc*p[i,h,kv,kv];
for lv:=1 to 2 do if (lv<>kv) then
begin
  cc:=p[i,1,lv,kv];
  for ii:=1 to kc do for ij:=1 to 2 do
  begin
    p[i,ii,lv,ij]:=p[i,ii,lv,ij]-cc*p[i,ii,kv,ij];
  end;
  p[i,h,lv,lv]:=p[i,h,lv,lv]-cc*p[i,h,kv,kv];
end;
end;
if (kc>1) then
begin
  for j:=2 to kc do
  begin
    jj:=kk[i,j];l:=kk[jj,h];jk:=1;
    for jl:=2 to 1 do begin if (kk[jj,jl]=i) then jk:=jl;end;
    for kv:=1 to 2 do for lv:=1 to 2 do g[kv,lv]:=p[jj,jk,kv,lv];
    kk[jj,jk]:=kk[jj,1];kk[jj,1]:=0;
    for kv:=1 to 2 do for lv:=1 to 2 do
    begin
      p[jj,jk,kv,lv]:=p[jj,1,kv,lv];p[jj,1,kv,lv]:=0;
      p[jj,h,lv,lv]:=p[jj,h,lv,lv]-g[lv,kv]*p[i,h,kv,kv];
    end;
    l:=l-1;kk[jj,h]:=1;
    for ii:=2 to kc do
    begin
      ij:=0;
      for ik:=1 to 1 do
      begin
        if (kk[jj,ik]=kk[i,ii]) then ij:=ik;
      end;
      if (ij=0) then
      begin
        l:=l+1;ij:=1;kk[jj,h]:=1;kk[jj,ij]:=kk[i,ii];
      end;
      for kv:=1 to 2 do for lv:=1 to 2 do for jv:=1 to 2 do
        p[jj,ij,kv,lv]:=p[jj,ij,kv,lv]-g[kv,jv]*p[i,ii,jv,lv];
      end;
    end;
  end;
end;

```

```

    end;
end;
for j:=0 to sub do
begin
  l:=kk[j,h];if (l>1) then
  begin
    for k:=2 to l do
    begin
      jj:=kk[j,k];
      for kv:=1 to 2 do for lv:=1 to 2 do
        p[j,h,kv,kv]:=p[j,h,kv,kv]-p[j,k,kv,lv]*p[jj,h,lv,lv];
      end;
    end;
  end;
end;
for i:=0 to sub do
begin
  m[i]:=p[i,h,1,1];u[i]:=p[i,h,2,2];
end;
q[0]:=-force;ff[0]:=0;
for i:=1 to sub do
begin
  aa:=(m[i]-m[i-1])/dz;q[i]:=-q[i-1]+2*aa;
  ff[i]:=q[i]-q[i-1];
end;
end;
procedure meshinput;
var
  i,j,k:integer;aa,c2,tc:real;name:string;
begin
  name:='MESH.DAT';
  assign(data,name);reset(data);readln(data,nn,mm);ll:=2*nn;
  for i:=1 to nn do readln(data,x[i],y[i],xt[i],yt[i]);
  aa:=diam/(2*x[2]);
  for i:=1 to nn do begin x[i]:=aa*x[i];y[i]:=aa*y[i];end;
  for j:=1 to mm do readln(data,nj[j,1],nj[j,2],nj[j,3],el[j]);
  close(data);
  for i:=1 to nn do for j:=1 to nm do begin ux[i,j]:=0;uy[i,j]:=0;end;
  band:=0;for j:=1 to mm do
  begin
    k:=abs(nj[j,1]-nj[j,2]);if (k>band) then band:=k;
    k:=abs(nj[j,2]-nj[j,3]);if (k>band) then band:=k;
    k:=abs(nj[j,3]-nj[j,1]);if (k>band) then band:=k;
  end;
end;

```

```

band:=2*(band+1);
if (band>maxband) then
  begin
    writeln('Band width too large.');
```

writeln;halt;

```

  end;
end;
procedure pileoutput;
var
  i,l,i1,i2:integer;
begin
  l:=0;i1:=0;while l=0 do
    begin
      title;
      writeln('          i          z          u          M          Q');
      writeln;i2:=i1+20;if (i2>sub) then i2:=sub;
      for i:=i1 to i2 do
        begin
          writeln(i:10,z[i]:14:6,u[i]:14:6,m[i]:14:6,q[i]:14:6);
        end;
      next;i1:=i1+20;if (i1>=sub) then l:=1;
    end;
  clrscr;
end;
procedure soilmatrix(layer:integer;iter:integer);
var
  i,j,k,ia,ib,iu,iv,ka,ku,kv,kk,kl,km:integer;
  d,aa,dd,ee,em,gm,pn,dg,a1,a2:real;xx,yy,b,c:array[1..3] of real;
  pa,qa,sa:array[1..3,1..3] of real;
begin
  for i:=1 to ll do
    begin
      r[i]:=0;for j:=1 to band do pp[i,j]:=0;
    end;
  write(' Layer ',layer:2,' : ');
  for j:=1 to mm do
    begin
      em:=es[layer]*el[j];gm:=el[j];pn:=ps[layer];
      if (layer<=nl) then
        begin
          k:=0;for i:=1 to 3 do if (nj[j,i]=1) then k:=1;
          if (k=1) then begin em:=em*1000;gm:=0;end;
        end;
      for i:=1 to 3 do
```

```

begin
  k:=nj[j,i];xx[i]:=x[k];yy[i]:=y[k];
end;
b[1]:=yy[2]-yy[3];b[2]:=yy[3]-yy[1];b[3]:=yy[1]-yy[2];
c[1]:=xx[3]-xx[2];c[2]:=xx[1]-xx[3];c[3]:=xx[2]-xx[1];
d:=abs(xx[1]*b[1]+xx[2]*b[2]+xx[3]*b[3]);gm:=gm*d/(6*dw*dw);
dd:=em/(4*d*(1+pn));ee:=2*pn/(1-2*pn);aa:=2+ee;
for i:=1 to 3 do for k:=1 to 3 do
  begin
    pa[i,k]:=dd*(aa*b[i]*b[k]+c[i]*c[k]);
    qa[i,k]:=dd*(ee*b[i]*c[k]+c[i]*b[k]);
    sa[i,k]:=dd*(aa*c[i]*c[k]+b[i]*b[k]);
  end;
end;
for i:=1 to 3 do
  begin
    ia:=nj[j,i];iu:=2*ia-1;
    for k:=1 to 3 do
      begin
        ka:=nj[j,k];ku:=2*ka-iu;if (ku>0) then
          begin
            kv:=ku+1;pp[iu,kv]:=pp[iu,kv]+pa[i,k];
            pp[iu,kv]:=pp[iu,kv]+qa[i,k];
          end;
        end;
      end;
    end;
  end;
for i:=1 to 3 do
  begin
    ia:=nj[j,i];iv:=2*ia;
    for k:=1 to 3 do
      begin
        ka:=nj[j,k];ku:=2*ka-iv;kv:=ku+1;if (kv>0) then
          begin
            pp[iv,kv]:=pp[iv,kv]+sa[i,k];
            if (ku>0) then pp[iv,kv]:=pp[iv,kv]+qa[k,i];
          end;
        end;
      end;
    end;
  end;
if (iter>1) then
  begin
    for k:=1 to 3 do
      begin
        i:=nj[j,k];ib:=2*i;ia:=ib-1;
        if (xt[i]<1) then

```

```

begin
  dg:=gm*gs[layer];if (layer<nm) then
  begin
    dg:=2*gm*gs[layer+1]*gs[layer]/(gs[layer+1]+gs[layer]);
    r[ia]:=r[ia]+dg*ux[i,layer+1];
  end;
  pp[ia,1]:=pp[ia,1]+dg;
  if (layer>1) then
  begin
    dg:=2*gm*gs[layer-1]*gs[layer]/(gs[layer-1]+gs[layer]);
    r[ia]:=r[ia]+dg*ux[i,layer-1];pp[ia,1]:=pp[ia,1]+dg;
  end;
end;
if (yt[i]<1) then
begin
  dg:=gm*gs[layer];if (layer<nm) then
  begin
    dg:=2*gm*gs[layer+1]*gs[layer]/(gs[layer+1]+gs[layer]);
    r[ib]:=r[ib]+gm*uy[i,layer+1];
  end;
  pp[ib,1]:=pp[ib,1]+gm;
  if (layer>1) then
  begin
    dg:=2*gm*gs[layer-1]*gs[layer]/(gs[layer-1]+gs[layer]);
    r[ib]:=r[ib]+dg*uy[i,layer-1];pp[ib,1]:=pp[ib,1]+dg;
  end;
end;
end;
end;
for i:=1 to nn do
begin
  k:=2*i-1;if xt[i]>0 then
  begin
    pp[k,1]:=1;if k>1 then
    begin
      kk:=k-band+1;kl:=k-1;if kk<1 then kk:=1;
      for j:=kk to kl do pp[j,k-j+1]:=0;
    end;
    for j:=2 to band do pp[k,j]:=0;
  end;
  k:=2*i;if yt[i]>0 then
  begin

```

```

    pp[k,1]:=1;kk:=k-band+1;if kk<1 then kk:=1;
    kl:=k-1;
    for j:=kk to kl do pp[j,k-j+1]:=0;
    if k<ll then for j:=2 to band do pp[k,j]:=0;
end;
end;
end;
procedure soilsolve(layer:integer;iter:integer;l:integer);
var
  i,j,k,ll,lm,jj,mm,nc,iz,ii:integer;
  a1,a2,a3,aa:real;
begin
  for i:=1 to l do
    begin
      ll:=band;lm:=l-i+1;if (ll>lm) then ll:=lm;
      for j:=1 to ll do
        begin
          a1:=pp[i,j];pp[i,j]:=1;jj:=j-1;mm:=band-jj;if (mm>i) then mm:=i;
          while mm>1 do
            begin
              k:=i-mm+1;a2:=pp[k,mm];a3:=pp[k,mm+jj];a1:=a1-pp[k,1]*a2*a3;
              mm:=mm-1;
            end;
          pp[i,j]:=a1/pp[i,1];
        end;
      end;
      r[1]:=fq[layer]/(4*dw);
      nc:=band-1;for i:=2 to l do
        begin
          a1:=r[i];k:=i-nc;if (k<1) then k:=1;
          iz:=i-1;for j:=k to iz do a1:=a1-pp[j,i-j+1]*r[j];
          r[i]:=a1;
        end;
      for i:=1 to l do r[i]:=r[i]/pp[i,1];
      for ii:=2 to l do
        begin
          i:=l-ii+1;a1:=r[i];iz:=i+nc;if (iz>l) then iz:=l;
          k:=i+1;for j:=k to iz do a1:=a1-pp[i,j-i+1]*r[j];
          r[i]:=a1;
        end;
      aa:=1;if (iter=1) and (layer<=nl) then aa:=uq[layer]/r[1];
      for i:=1 to nn do
        begin

```

```

      k:=2*i;j:=k-1;ux[i,layer]:=aa*r[j];uy[i,layer]:=aa*r[k];
    end;
    r[1]:=aa*r[1];writeln('u = ',r[1]:12:6);
  end;
procedure pilereaction1;
var
  i,j,k:integer;a,b:real;
begin
  for i:=1 to nm do begin uq[i]:=0;fq[i]:=0;end;
  uq[1]:=u[0];
  for i:=1 to nl do
    begin
      a:=i*dw;b:=a-dw;k:=0;if (i=1) then k:=1;
      for j:=0 to sub do
        begin
          if (z[j]>b) and (z[j]<=a) then
            begin
              fq[i]:=fq[i]+ff[j];uq[i]:=uq[i]+u[j];k:=k+1;
            end;
          end;
          uq[i]:=uq[i]/k;
        end;
      end;
    end;
  end;
procedure pilereaction2;
var
  i,j,k:integer;a,b,c,d,aa:real;
begin
  d:=0.000001;
  for i:=1 to nl do
    begin
      a:=i*dw;b:=a-dw;k:=0;c:=0;fq[i]:=0;
      if (i=1) then begin k:=1;c:=p[0,maxwid,2,2];end;
      for j:=0 to sub do
        begin
          if (z[j]>b) and (z[j]<=a) then
            begin
              fq[i]:=fq[i]+ff[j];c:=c+p[j,maxwid,2,2];k:=k+1;
            end;
          end;
          c:=c/k;if (abs(uq[i])<d) then aa:=c/d else aa:=c/uq[i];
        end;
      end;
    end;
  end;
  for j:=1 to mn do
    begin
      ux[j,i]:=aa*ux[j,i];uy[j,i]:=aa*uy[j,i];
    end;
  end;
end;

```

```

    end;
  end;
end;
procedure update;
var
  i,j,k:integer;a,b,d,rs:real;
begin
  d:=0.000001;
  for i:=1 to nl do
    begin
      a:=i*dw;b:=a-dw;if (abs(uq[i])<d) then uq[i]:=d;
      rs:=abs(fq[i]/(dw*uq[i]));
      for j:=0 to sub do
        begin
          if (z[j]>b) and (z[j]<=a) then s[j]:=rs*dz;
        end;
      end;
    end;
  end;
procedure test(var fin:integer;iter:integer);
var
  a,b,c,d:real;i:integer;
begin
  a:=abs(error*vq[1]);c:=0;
  for i:=1 to nl do begin d:=abs(error*vq[i]);if (d>a) then a:=d;end;
  for i:=1 to nl do
    begin
      b:=abs(uq[i]-vq[i]);uq[i]:=vq[i];if (b>c) then c:=b;
    end;
  fin:=1;if (c>a) and (iter<maxit) then fin:=-1;
  if (iter=1) then fin:=-1;
end;
begin
input;meshinput;title;writeln;fin:=-1;it:=0;
while (fin<0) do
  begin
    it:=it+1;title;writeln('Iteration ',it);writeln('Analysis of pile');
    pilematrix;pilesolve;
    if (it=1) then pilereaction1 else pilereaction2;
    writeln('Analysis of soil');
    for il:=1 to nm do
      begin
        soilmatrix(il,it);soilsolve(il,it,ll);vq[il]:=r[1];
      end;
    end;
  end;
end;

```



```
test(fin,it);update;
end;
pileoutput;
end.
```

Program PILAT.

```
37 54
0.000 0.000 0 2
3.000 0.000 0 2
2.828 1.000 0 2
2.120 2.120 0 2
1.000 2.828 0 2
0.000 3.000 0 2
5.000 0.000 0 2
5.000 3.000 0 0
3.000 3.000 0 0
3.000 5.000 0 0
0.000 5.000 0 2
8.000 0.000 0 2
8.000 3.000 0 0
5.000 5.000 0 0
3.000 8.000 0 0
0.000 8.000 0 2
13.000 0.000 0 2
13.000 8.000 0 0
8.000 8.000 0 0
8.000 13.000 0 0
0.000 13.000 0 2
23.000 0.000 0 2
23.000 13.000 0 0
13.000 13.000 0 0
13.000 23.000 0 0
0.000 23.000 0 2
43.000 0.000 0 2
43.000 23.000 0 0
23.000 23.000 0 0
23.000 43.000 0 0
0.000 43.000 0 2
43.000 43.000 0 0
90.000 0.000 2 2
90.000 43.000 2 2
90.000 90.000 2 2
```

43.000	90.000	2	2
0.000	90.000	2	2
1	2	3	1.0
1	3	4	1.0
1	4	5	1.0
1	5	6	1.0
2	3	7	1.0
3	7	8	1.0
3	8	9	1.0
3	4	9	1.0
4	5	9	1.0
5	9	10	1.0
5	10	11	1.0
5	6	11	1.0
7	12	13	1.0
7	8	13	1.0
8	13	14	1.0
8	9	14	1.0
13	14	19	1.0
9	10	14	1.0
14	15	19	1.0
10	14	15	1.0
10	11	15	1.0
11	15	16	1.0
12	13	17	1.0
13	17	18	1.0
13	18	19	1.0
18	19	24	1.0
19	20	24	1.0
15	19	20	1.0
15	20	21	1.0
15	16	21	1.0
17	18	22	1.0
18	22	23	1.0
18	23	24	1.0
23	24	29	1.0
24	25	29	1.0
20	24	25	1.0
20	25	26	1.0
20	21	26	1.0
22	23	27	1.0
23	27	28	1.0
23	28	29	1.0

28	29	32	1.0
29	30	32	1.0
25	29	30	1.0
25	30	31	1.0
25	26	31	1.0
27	28	33	0.5
28	33	34	0.5
28	32	34	0.5
32	34	35	0.5
32	35	36	0.5
30	32	36	0.5
30	36	37	0.5
30	31	37	0.5

Datafile MESH.DAT.

Some results for an example are shown in figure 9.2. The example concerns a pile in a soil consisting of 10 layers, with the elastic stiffness

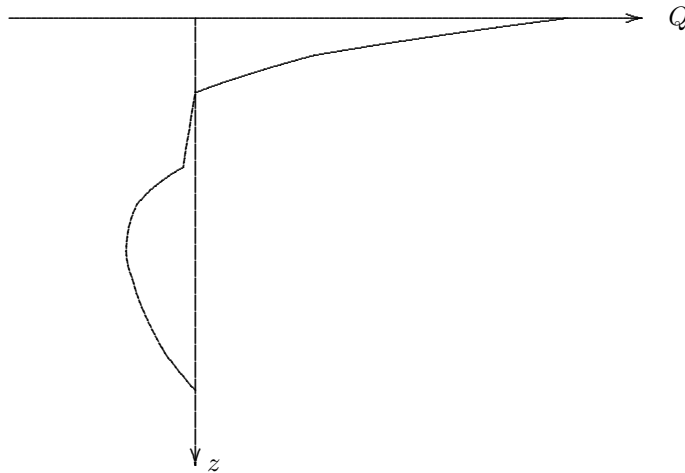

Figure 9.2: Shear force distribution.

of layers 3 and 4 being 10 times smaller than that of the other layers. The shear force distribution is shown in figure 9.2. It can be seen that in

the weaker section the shear force is practically constant, which indicates that the lateral force (the derivative of the shear force) is indeed very small there.

A more advanced model (LPG) has been developed by Kooijman (1989). In this model the soil layers have elasto-plastic properties, and the geometry in the horizontal plane is more general, so that a group of closely spaced piles can be represented. This makes it possible to include the mutual influence of the piles on their displacements, even in case of overlapping plastic zones. In the Kooijman model it is also possible to take into account the possible development of a gap in the wake of each pile, if the tensile strength of the soil is exceeded. The program is distributed by the Foundation of Engineering Sciences (STW).

Chapter 10

WAVES IN PILES

In this chapter the problem of the propagation of compression waves in piles is studied. This problem is of importance when considering the behaviour of a pile and the soil during pile driving, and under dynamic loading. Because of the one-dimensional character of the problem this is also one of the simplest problems of wave propagation in a mathematical sense, and therefore it may be used to illustrate some of the main characteristics of dynamics. Several methods of analysis will be used : the Laplace transform method, separation of variables, the method of characteristics, and numerical solution.

10.1 Basic equation

Consider a pile of constant cross sectional area A , consisting of a linear elastic material, with modulus of elasticity E . If there is no friction along the shaft of the pile the equation of motion of an element is

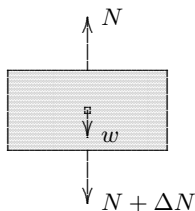

$$\frac{\partial N}{\partial z} = \rho A \frac{\partial^2 w}{\partial t^2}, \quad (10.1)$$

where ρ is the mass density of the material, and w is the displacement in axial direction. The normal force N is related to the stress by

$$N = \sigma A,$$

Figure 10.1: Element of axially loaded pile and the stress is related to the strain by Hooke's law for the pile material

$$\sigma = E\varepsilon.$$

Finally, the strain is related to the vertical displacement w by the relation

$$\varepsilon = \partial w / \partial z.$$

Thus the normal force N is related to the vertical displacement w by the relation

$$N = EA \frac{\partial w}{\partial z}. \quad (10.2)$$

Substitution of eq. (10.2) into eq. (10.1) gives

$$E \frac{\partial^2 w}{\partial z^2} = \rho \frac{\partial^2 w}{\partial t^2}. \quad (10.3)$$

This is the *wave equation*. It can be solved analytically, for instance by the Laplace transform method or by the method of characteristics, or it can be solved numerically. All these techniques are presented in this chapter. The analytical solution will give insight into the behaviour of the solution. A numerical model is particularly useful for more complicated problems, involving friction along the shaft of the pile, and non-uniform properties of the pile and the soil.

10.2 Solution by Laplace transform method

Many problems of one-dimensional wave propagation can be solved conveniently by the Laplace transform method (Churchill, 1972). Some examples of this technique are given in this section.

10.2.1 Pile of infinite length

The Laplace transform of the displacement w is defined by

$$\bar{w}(z, s) = \int_0^\infty w(z, t) \exp(-st) dt, \quad (10.4)$$

where s is the Laplace transform parameter, which can be assumed to have a positive real part. Now consider the problem of a pile of infinite length, which is initially at rest, and on the top of which a constant pressure is applied, starting at time $t = 0$. The Laplace transform of the differential equation (10.3) now is

$$\frac{d^2 \bar{w}}{dz^2} = \frac{s^2}{c^2} \bar{w}, \quad (10.5)$$

where c is the wave velocity,

$$c = \sqrt{E/\rho}. \quad (10.6)$$

The solution of the ordinary differential equation (10.5) which vanishes at infinity is

$$\bar{w} = A \exp(-sz/c). \quad (10.7)$$

The integration constant A (which may depend upon the transformation parameter s , but not on z) can be obtained from the boundary condition. For a constant pressure p_0 applied at the top of the pile this boundary condition is

$$z = 0, t > 0 : E \frac{\partial w}{\partial z} = -p_0. \quad (10.8)$$

The Laplace transform of this boundary condition is

$$z = 0 : E \frac{d\bar{w}}{dz} = -\frac{p_0}{s}. \quad (10.9)$$

With (10.7) the value of the constant A can now be determined. The result is

$$A = \frac{pc}{Es^2}, \quad (10.10)$$

so that the final solution of the transformed problem is

$$\bar{w} = \frac{pc}{Es^2} \exp(-sz/c). \quad (10.11)$$

The inverse transform of this function can be found in elementary tables of Laplace transforms, see for instance Abramowitz & Stegun (1964) or Churchill (1972). The final solution now is

$$w = \frac{pc(t - z/c)}{E} H(t - z/c), \quad (10.12)$$

where $H(t - t_0)$ is Heaviside's unit step function, defined as

$$H(t - t_0) = \begin{cases} 0, & \text{if } t < t_0, \\ 1, & \text{if } t > t_0. \end{cases} \quad (10.13)$$

The solution (10.12) indicates that a point in the pile remains at rest as long as $t < z/c$. From that moment on (this is the moment of arrival of the wave) the point starts to move, with a linearly increasing displacement, which represents a constant velocity.

It may seem that this solution is in disagreement with Newton's second law, which states that the velocity of a mass point will linearly increase in time when a constant force is applied. In the present case the velocity is constant. The moving mass gradually increases, however, so that the results are really in agreement with Newton's second law : the momentum (mass times velocity) linearly increases with time. Actually, Newton's second law is the basic principle involved in deriving the basic differential equation (10.3), so that no disagreement is possible, of course.

10.2.2 Pile of finite length



Figure 10.2: Pile of finite length.

The Laplace transform method can also be used for the analysis of waves in piles of finite length. Many solutions can be found in the literature (Churchill, 1972; Carslaw & Jaeger, 1948). An example will be given below.

Consider the case of a pile of finite length, say h , see figure 10.2. The boundary $z = 0$ is free of stress, and the boundary $z = h$ undergoes a sudden displacement at time $t = 0$. Thus the boundary conditions are

$$z = 0, t > 0 : \frac{\partial w}{\partial z} = 0, \quad (10.14)$$

and

$$z = h, t > 0 : w = w_0. \quad (10.15)$$

The general solution of the transformed differential equation

$$\frac{d^2 \bar{w}}{dz^2} = \frac{s^2}{c^2} \bar{w}, \quad (10.16)$$

is

$$\bar{w} = A \exp(sz/c) + B \exp(-sz/c). \quad (10.17)$$

The constants A and B (which may depend upon the Laplace transform parameter s) can be determined from the transforms of the boundary conditions (10.14) and (10.15). The result is

$$\bar{w} = \frac{w_0}{s} \frac{\cosh(sz/c)}{\cosh(sh/c)}. \quad (10.18)$$

The mathematical problem now remaining is to find the inverse transform of this expression. This can be accomplished by using the complex inversion integral (Churchill, 1972), or its simplified form, the Heaviside expansion theorem, see Appendix A. This gives, after some mathematical elaborations,

$$\frac{w}{w_0} = 1 - \frac{4}{\pi} \sum_{k=0}^{\infty} \frac{(-1)^k}{(2k+1)} \cos\left[(2k+1)\frac{\pi z}{2h}\right] \cos\left[(2k+1)\frac{\pi ct}{2h}\right]. \quad (10.19)$$

As a special case one may consider the displacement of the free end $z = 0$,

$$z = 0 : \frac{w}{w_0} = 1 - \frac{4}{\pi} \sum_{k=0}^{\infty} \frac{(-1)^k}{(2k+1)} \cos\left[(2k+1)\frac{\pi ct}{2h}\right]. \quad (10.20)$$

This expression is of the form of a Fourier series. Actually, it is the same series as the one given in the example in Appendix A, except for a constant factor and some changes in notation. The summation of the series is shown in figure 10.3. It appears that the end remains at rest for a time h/c , then suddenly shows a displacement $2w_0$ for a time span $2h/c$, and then switches continuously between zero displacement and $2w_0$. The physical interpretation, which may become more clear after considering the solution of the problem by the method of characteristics in a later section, is that a compression wave starts to travel at time $t = 0$ towards the free end, and then is reflected as a tension wave in order that the end remains free. The time h/c is the time needed for each wave to travel through the pile.

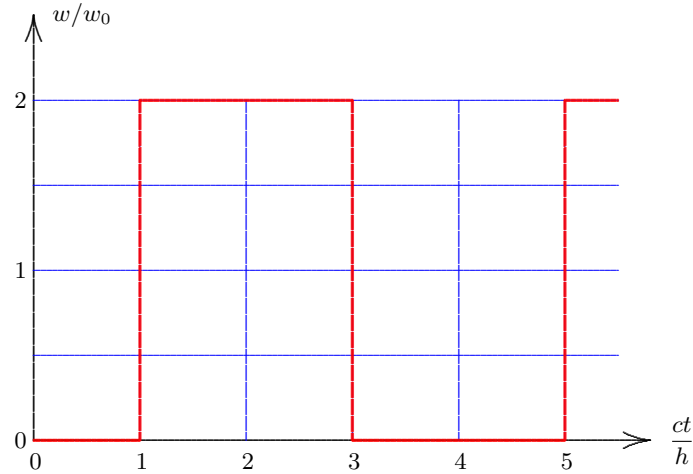

Figure 10.3: Displacement of free end.

10.3 Separation of variables

For certain problems, especially problems of continuous vibrations, the differential equation (10.3) can be solved conveniently by separation of variables. Two examples will be considered in this section.

10.3.1 Shock wave in finite pile

As an example of the general technique used in the method of separation of variables the problem of a pile of finite length loaded at time $t = 0$ by a constant displacement at one of its ends will be considered once more. The differential equation is

$$\frac{\partial^2 w}{\partial t^2} = c^2 \frac{\partial^2 w}{\partial z^2}, \quad (10.21)$$

with the boundary conditions

$$z = 0, t > 0 : \frac{\partial w}{\partial z} = 0, \quad (10.22)$$

and

$$z = h, t > 0 : w = w_0. \quad (10.23)$$

The first condition expresses that the boundary $z = 0$ is a free end, and the second condition expresses that the boundary $z = h$ is displaced by an amount w_0 at time $t = 0$. The initial conditions are supposed to be that the pile is at rest at $t = 0$.

The solution of the problem is now sought in the form

$$w = w_0 + Z(z)T(t). \quad (10.24)$$

The basic assumption here is that solutions can be written as a product of two functions, a function $Z(z)$, which depends upon z only, and another function $T(t)$, which depends only on t . Substitution of (10.24) into the differential equation (10.21) gives

$$\frac{1}{c^2} \frac{1}{T} \frac{d^2 T}{dt^2} = \frac{1}{Z} \frac{d^2 Z}{dz^2}. \quad (10.25)$$

The left hand side of this equation depends upon t only, the right hand side depends upon z only. Therefore the equation can be satisfied only if both sides are equal to a certain constant. This constant may be assumed to be negative or positive. If it is assumed that this constant is negative one may write

$$\frac{1}{Z} \frac{d^2 Z}{dz^2} = -\lambda^2, \quad (10.26)$$

where λ is an unknown constant. The general solution of eq. (10.26) is

$$Z = A \cos(\lambda z) + B \sin(\lambda z), \quad (10.27)$$

where A and B are constants. They can be determined from the boundary conditions. Because dZ/dz must be 0 for $z = 0$ it follows that $B = 0$. If now it is required that $Z = 0$ for $z = h$, in order to satisfy the boundary condition (10.23) it follows that either $A = 0$, which leads to the useless solution $w = 0$, or $\cos(\lambda h) = 0$, which can be satisfied if

$$\lambda = \lambda_k = (2k + 1) \frac{\pi}{2h}, \quad k = 0, 1, 2, \dots \quad (10.28)$$

On the other hand, one obtains for the function T

$$\frac{1}{T} \frac{d^2 T}{dt^2} = -c^2 \lambda^2, \quad (10.29)$$

with the general solution

$$T = A \cos(\lambda ct) + B \sin(\lambda ct). \quad (10.30)$$

The solution for the displacement w can now be written as

$$w = w_0 + \sum_{k=0}^{\infty} [A_k \cos(\lambda_k ct) + B_k \sin(\lambda_k ct)] \cos(\lambda_k z). \quad (10.31)$$

The velocity now is

$$\frac{\partial w}{\partial t} = \sum_{k=0}^{\infty} [-A_k \lambda_k c \sin(\lambda_k c t) + B_k \lambda_k c \cos(\lambda_k c t)] \cos(\lambda_k z). \quad (10.32)$$

Because this must be zero for all values of z (this is an initial condition) it follows that $B_k = 0$. On the other hand, the initial condition that the displacement must also be zero for $t = 0$, now leads to the equation

$$\sum_{k=0}^{\infty} A_k \cos(\lambda_k z) = -w_0, \quad (10.33)$$

which must be satisfied for all values of z in the range $0 < z < h$. This is the standard problem from Fourier series analysis, see Appendix A. It can be solved by multiplication of both sides by $\cos(\lambda_j z)$, and then integrating both sides over z from $z = 0$ to $z = h$. The result is

$$A_k = \frac{4}{\pi} \frac{w_0}{(2k+1)} (-1)^k. \quad (10.34)$$

Substitution of this result into the solution (10.31) now gives finally, with $B_k = 0$,

$$\frac{w}{w_0} = 1 + \frac{4}{\pi} \sum_{k=0}^{\infty} \frac{(-1)^k}{(2k+1)} \cos\left[(2k+1)\frac{\pi z}{2h}\right] \cos\left[(2k+1)\frac{\pi c t}{2h}\right]. \quad (10.35)$$

This is exactly the same result as found earlier by using the Laplace transform method, see eq. (10.19). It may give some confidence that both methods lead to the same result.

The solution (10.35) can be seen as a summation of periodic solutions, each combined with a particular shape function. Usually a periodic function is written as $\cos(\omega t)$. In this case it appears that the possible frequencies are

$$\omega = \omega_k = (2k+1)\frac{\pi c}{2h}, \quad k = 0, 1, 2, \dots \quad (10.36)$$

These are usually called the *characteristic frequencies*, or *eigen frequencies* of the system. The corresponding shape functions

$$\psi_k(z) = \cos\left[(2k+1)\frac{\pi z}{2h}\right], \quad k = 0, 1, 2, \dots, \quad (10.37)$$

are called the *eigen functions* of the system.

10.3.2 Periodic load



Figure 10.4: Pile loaded by periodic pressure.

The solution is much simpler if the load is periodic, because then it can be assumed that all displacements are periodic. As an example the problem of a pile of finite length, loaded by a periodic load at one end, and rigidly supported at its other end, will be considered, see figure 10.4. In this case the boundary conditions at the left side boundary, where the pile is supported by a rigid wall or foundation, is

$$z = 0 : w = 0. \quad (10.38)$$

The boundary condition at the other end is

$$z = h : E \frac{\partial w}{\partial z} = -p_0 \sin(\omega t), \quad (10.39)$$

where h is the length of the pile, and ω is the frequency of the periodic load.

It is again assumed that the solution of the partial differential equation (10.3) can be written as the product of a function of z and a function of t . In particular, because the load is periodic, it is now assumed that

$$w = W(z) \sin(\omega t). \quad (10.40)$$

Substitution into the differential equation (10.3) shows that this equation can indeed be satisfied, provided that the function $W(z)$ satisfies the ordinary differential equation

$$\frac{d^2 W}{dz^2} = -\frac{\omega^2}{c^2} W, \quad (10.41)$$

where $c = \sqrt{E/\rho}$, the wave velocity.

The solution of the differential equation (10.41) that also satisfies the two boundary conditions (10.38) and (10.39) is

$$W(z) = -\frac{p_0 c}{E \omega} \frac{\sin(\omega z/c)}{\cos(\omega h/c)}. \quad (10.42)$$

This means that the final solution of the problem is, with (10.42) and (10.40),

$$w(z, t) = -\frac{p_0 c}{E \omega} \frac{\sin(\omega z/c)}{\cos(\omega h/c)} \sin(\omega t). \quad (10.43)$$

It can easily be verified that this solution satisfies all requirements, because it satisfies the differential equation, and both boundary conditions. Thus a complete solution has been obtained by elementary procedures. Of special interest is the motion of the free end of the pile. This is found to be

$$w(h, t) = w_0 \sin(\omega t), \quad (10.44)$$

where

$$w_0 = -\frac{p_0 c}{E \omega} \tan(\omega h / c). \quad (10.45)$$

The amplitude of the total force, $F_0 = -p_0 A$, can be written as

$$F_0 = \frac{EA}{c} \frac{\omega}{\tan(\omega h / c)} w_0. \quad (10.46)$$

Resonance

It may be interesting to consider in particular the case that the frequency ω is equal to one of the eigen frequencies of the system,

$$\omega = \omega_k = (2k + 1) \frac{\pi c}{2h}, \quad k = 0, 1, 2, \dots \quad (10.47)$$

In that case $\cos(\omega h / c) = 0$, and the amplitude of the displacement, as given by eq. (10.45), becomes infinitely large. This phenomenon is called *resonance* of the system. If the frequency of the load equals one of the eigen frequencies of the system, this may lead to very large displacements, indicating resonance.

In engineering practice the pile may be a concrete foundation pile, for which the order of magnitude of the wave velocity c is about 3000 m/s, and for which a normal length h is 20 m. In civil engineering practice the frequency ω is usually not very large, at least during normal loading. A relatively high frequency is say $\omega = 20 \text{ s}^{-1}$. In that case the value of the parameter $\omega h / c$ is about 0.13, which is rather small, much smaller than all eigen frequencies (the smallest of which occurs for $\omega h / c = \pi / 2$). The function $\tan(\omega h / c)$ in (10.46) may now be approximated by its argument, so that this expression reduces to

$$\omega h / c \ll 1 : F_0 \approx \frac{EA}{h} w_0. \quad (10.48)$$

This means that the pile can be considered to behave, as a first approximation, as a spring, without mass, and without damping. In many situations in civil engineering practice the loading is so slow, and the elements are so stiff (especially when they consist of concrete or steel), that the dynamic analysis can be restricted to the motion of a single spring.

It must be noted that the approximation presented above is not always justified. When the material is soft (e.g. soil) the velocity of wave propagation may not be that high. And loading conditions with very high frequencies may also be of importance, for instance during installation (pile driving). In general one may say that in order for dynamic effects to be negligible, the loading must be so slow that the frequency is considerably smaller than the smallest eigen frequency.

10.4 Solution by characteristics

A powerful method of solution for problems of wave propagation in one dimension is provided by the method of characteristics. This method is presented in this section.

The wave equation (10.3) has solutions of the form

$$w = f_1(z - ct) + f_2(z + ct), \quad (10.49)$$

where f_1 and f_2 are arbitrary functions, and c is the velocity of propagation of waves,

$$c = \sqrt{E/\rho}. \quad (10.50)$$

In mathematics the directions $z = ct$ and $z = -ct$ are called the *characteristics*. The solution of a particular problem can be obtained from the general solution (10.49) by using the initial conditions and the boundary conditions.

A convenient way of constructing solutions is by writing the basic equations in the following form

$$\frac{\partial \sigma}{\partial z} = \rho \frac{\partial v}{\partial t}, \quad (10.51)$$

$$\frac{\partial \sigma}{\partial t} = E \frac{\partial v}{\partial z}, \quad (10.52)$$

where v is the velocity, $v = \partial w / \partial t$, and σ is the stress in the pile.

In order to simplify the basic equations two new variables ξ and η are introduced, defined by

$$\xi = z - ct, \quad \eta = z + ct. \quad (10.53)$$

The equations (10.51) and (10.52) can now be transformed into

$$\frac{\partial \sigma}{\partial \xi} + \frac{\partial \sigma}{\partial \eta} = \rho c \left(-\frac{\partial v}{\partial \xi} + \frac{\partial v}{\partial \eta} \right), \quad (10.54)$$

$$\frac{\partial \sigma}{\partial \xi} - \frac{\partial \sigma}{\partial \eta} = \rho c \left(\frac{\partial v}{\partial \xi} + \frac{\partial v}{\partial \eta} \right), \quad (10.55)$$

from which it follows, by addition or subtraction of the two equations, that

$$\frac{\partial(\sigma - Jv)}{\partial \eta} = 0, \quad (10.56)$$

$$\frac{\partial(\sigma + Jv)}{\partial \xi} = 0, \tag{10.57}$$

where J is the impedance,

$$J = \rho c = \sqrt{E\rho}. \tag{10.58}$$

In terms of the original variables z and t the equations are

$$\frac{\partial(\sigma - Jv)}{\partial(z + ct)} = 0, \tag{10.59}$$

$$\frac{\partial(\sigma + Jv)}{\partial(z - ct)} = 0. \tag{10.60}$$

These equations mean that the quantity $\sigma - Jv$ is independent of $z + ct$, and $\sigma + Jv$ is independent of $z - ct$. This means that

$$\sigma - Jv = f_1(z - ct), \tag{10.61}$$

$$\sigma + Jv = f_2(z + ct). \tag{10.62}$$

These equations express that the quantity $\sigma - Jv$ is a function of $z - ct$ only, and that $\sigma + Jv$ is a function of $z + ct$ only. This means that $\sigma - Jv$ is constant when $z - ct$ is constant, and that $\sigma + Jv$ is constant when $z + ct$ is constant. These properties enable to construct solutions, either in a formal analytical way, or graphically, by mapping the solution, as represented by the variables σ and Jv , onto the plane of the independent variables z and ct .

As an example let there be considered the case of a free pile, which is hit at its upper end $z = 0$ at time $t = 0$ such that the stress at that end is $-p$. The other end, $z = h$, is free, so that the stress is zero there. The initial state is such that all velocities are zero. The solution is illustrated in figure 10.5. In the upper figure, the diagram of z and ct has been drawn, with lines of constant $z - ct$ and lines of constant $z + ct$. Because initially the velocity v and the stress σ are zero throughout the pile, the condition in each point of the pile is represented by the point 1 in the lower figure, the diagram of σ and Jv . The points in the lower left corner of the upper diagram (this region is marked 1) can all be reached from points on the axis $ct = 0$ (for which $\sigma = 0$ and $Jv = 0$) by a downward going

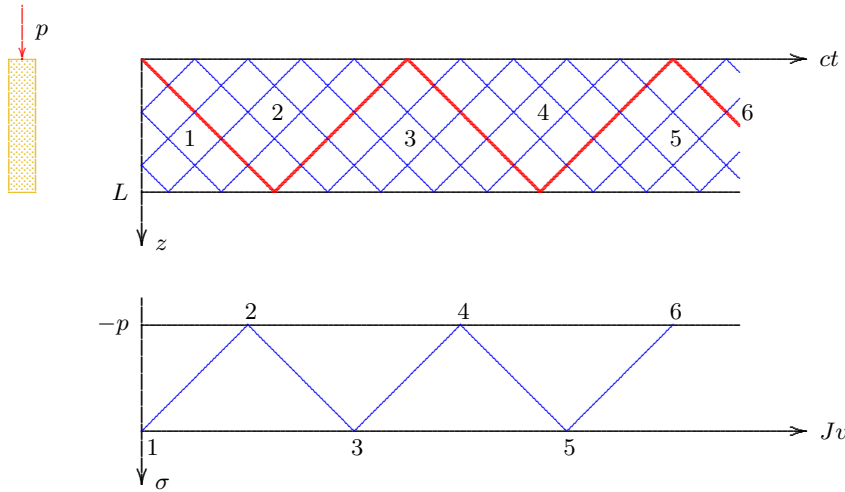

Figure 10.5: The method of characteristics.

characteristic, i.e. lines $z - ct = \text{constant}$. Thus in all these points $\sigma - Jv = 0$. At the bottom of the pile the stress is always zero, $\sigma = 0$. Thus in the points in region 1 for which $z = 0$ the velocity is also zero, $Jv = 0$. Actually, in the entire region 1 : $\sigma = Jv = 0$, because all these points can be reached by an upward going characteristic and a downward going characteristic from points where $\sigma = Jv = 0$. The point 1 in the lower diagram thus is representative for all points in region 1 in the upper diagram.

For $t > 0$ the value of the stress σ at the upper boundary $z = 0$ is $-p$, for all values of t . The velocity is unknown, however. The axis $z = 0$ in the upper diagram can be reached from points in the region 1 along lines for which $z + ct = \text{constant}$. Therefore the corresponding point in the diagram of σ and Jv must be located on the line for which $\sigma + Jv = \text{constant}$, starting from point 1. Because the stress σ at the top of the pile must be $-p$ the point in the lower diagram must be point 2. This means that the velocity is $Jv = p$, or $v = p/J$. This is the velocity of the top of the pile for a certain time, at least for $ct = 2h$, if h is the length of the pile, because all points for which $z = 0$ and $ct < 2h$ can be reached from region 1 along characteristics $z + ct = \text{constant}$.

At the lower end of the pile the stress σ must always be zero, because the pile was assumed to be not supported. Points in the upper diagram on the line $z = h$ can be reached from region 2 along lines of constant $x - ct$. Therefore they must be located on a line of constant $N - Jv$ in the lower diagram, starting from point 2. This gives point 3, which means that the velocity at the lower end of the pile is now $v = 2p/J$. This velocity applies to all points in the region 3 in the upper diagram.

In this way the velocity and the stress in the pile can be analyzed in successive steps. The thick lines in the upper diagram are the boundaries of the various regions. If the force at the top continues to be applied, as is assumed in figure 10.5, the velocity of the pile increases continuously. Figure 10.6 shows the velocity of the bottom of the pile as a function of time. The velocity gradually increases with time, because the pressure p at the top of the pile continues to act. This is in agreement with Newton's second law, which states that the velocity will continuously increase under the influence of a constant force.

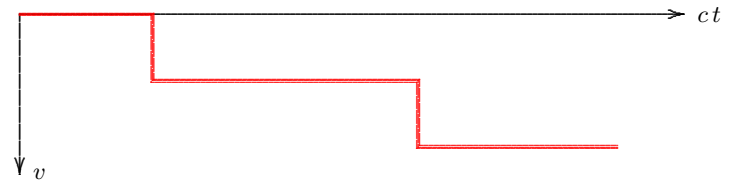

Figure 10.6: Velocity of the bottom of the pile.

10.5 Reflection and transmission of waves



Figure 10.7: Non-homogeneous pile.

end of the pile. The pile consists of two materials : first a stiff section, and then a very long section of smaller stiffness.

An interesting aspect of wave propagation in continuous media is the behaviour of waves at surfaces of discontinuity of the material properties. In order to study this phenomenon let us consider the propagation of a short shock wave in a pile consisting of two materials, see figure 10.7. A compression wave is generated in the pile by a pressure of short duration at the left

In the first section the solution of the problem of wave propagation can be written as

$$v = v_1 = f_1(z - c_1t) + f_2(z + c_1t), \quad (10.63)$$

$$\sigma = \sigma_1 = -\rho_1c_1f_1(z - c_1t) + \rho_1c_1f_2(z + c_1t), \quad (10.64)$$

where ρ_1 is the density of the material in that section, and c_1 is the wave velocity, $c_1 = \sqrt{E_1/\rho_1}$. It can easily be verified that this solution satisfies the two basic differential equations (10.51) and (10.52),

$$\frac{\partial \sigma}{\partial z} = \rho \frac{\partial v}{\partial t}, \quad (10.65)$$

$$\frac{\partial \sigma}{\partial t} = E \frac{\partial v}{\partial z}. \quad (10.66)$$

In the second part of the pile the solution is

$$v = v_2 = g_1(z - c_2t) + g_2(z + c_2t), \quad (10.67)$$

$$\sigma = \sigma_2 = -\rho_2c_2g_1(z - c_2t) + \rho_2c_2g_2(z + c_2t), \quad (10.68)$$

where ρ_2 and c_2 are the density and the wave velocity in that part of the pile.

At the interface of the two materials the value of z is the same in both solutions, say $z = h$, and the condition is that both the velocity v and the normal stress σ must be continuous at that point, at all values of time. Thus one obtains

$$f_1(h - c_1t) + f_2(h + c_1t) = g_1(h - c_2t) + g_2(h + c_2t), \quad (10.69)$$

$$-\rho_1c_1f_1(h - c_1t) + \rho_1c_1f_2(h + c_1t) = -\rho_2c_2g_1(h - c_2t) + \rho_2c_2g_2(h + c_2t). \quad (10.70)$$

If we write

$$f_1(h - c_1t) = F_1(t), \quad (10.71)$$

$$f_2(h + c_1t) = F_2(t), \quad (10.72)$$

$$g_1(h - c_2t) = G_1(t), \quad (10.73)$$

$$g_2(h + c_2t) = G_2(t), \quad (10.74)$$

then the continuity conditions are

$$F_1(t) + F_2(t) = G_1(t) + G_2(t) \quad (10.75)$$

$$-\rho_1c_1F_1(t) + \rho_1c_1F_2(t) = -\rho_2c_2G_1(t) + \rho_2c_2G_2(t). \quad (10.76)$$

In general these equations are, of course, insufficient to solve for the four functions. However, if it is assumed that the pile is very long (or, more generally speaking, when the value of time is so short that the wave reflected from the end of the pile has not yet arrived), it may be assumed that the solution representing the wave coming from the end of the pile is zero, $G_2(t) = 0$. In that case the solutions F_2 and G_1 can be expressed in the first wave, F_1 , which is the wave coming from the top of the pile. The result is

$$F_2(t) = \frac{\rho_1 c_1 - \rho_2 c_2}{\rho_1 c_1 + \rho_2 c_2} F_1(t), \quad (10.77)$$

$$G_1(t) = \frac{2\rho_1 c_1}{\rho_1 c_1 + \rho_2 c_2} F_1(t), \quad (10.78)$$

This means, for instance, that whenever the first wave $F_1(t) = 0$ at the interface, then there is no reflected wave, $F_2(t) = 0$, and there is no transmitted wave either, $G_1(t) = 0$. On the other hand, when the first wave has a certain value at the interface, then the values of the reflected wave and the transmitted wave at that point may be calculated from the relations (10.77) and (10.78). If the values are known the values at later times may be calculated using the relations (10.71) – (10.74).

The procedure may be illustrated by an example. Therefore let it be assumed that the two parts of the pile have the same density, $\rho_1 = \rho_2$, but the stiffness in the first section is 9 times the stiffness in the rest of the pile, $E_1 = 9E_2$. This means that the wave velocities differ by a factor 3, $c_1 = 3c_2$. The reflection coefficient and the transmission coefficient now are, with (10.77) and (10.78),

$$R_v = \frac{\rho_1 c_1 - \rho_2 c_2}{\rho_1 c_1 + \rho_2 c_2} = 0.5, \quad (10.79)$$

$$T_v = \frac{2\rho_1 c_1}{\rho_1 c_1 + \rho_2 c_2} = 1.5. \quad (10.80)$$

The behaviour of the solution is illustrated graphically in figure 10.8, in which the left half shows the velocity profile at various times. In the first four diagrams the incident wave travels toward the interface. During this period there is no reflected wave, and no transmitted wave in the second part of the pile. As soon as the incident wave hits the interface a reflected wave is generated, and a wave is transmitted into the second part of the pile. The magnitude of the velocities in this transmitted wave is 1.5 times the original wave, and it travels a factor 3 slower. The magnitude of the velocities in the reflected wave is 0.5 times those in the original wave.

The stresses in the two parts of the pile are shown in graphical form in the right half of figure 10.8. The reflection coefficient and the transmission coefficient for the stresses can be obtained using the equations (10.64) and (10.68). The result is

$$R_\sigma = -\frac{\rho_1 c_1 - \rho_2 c_2}{\rho_1 c_1 + \rho_2 c_2} = -0.5, \quad (10.81)$$

$$T_\sigma = \frac{2\rho_2 c_2}{\rho_1 c_1 + \rho_2 c_2} = 0.5. \quad (10.82)$$

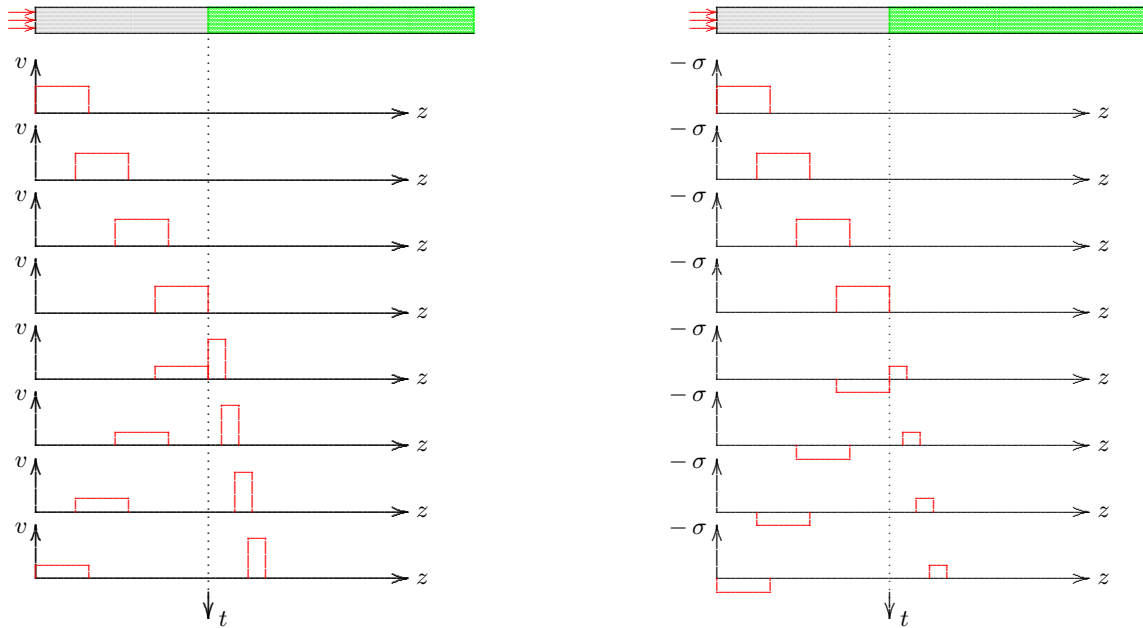

Figure 10.8: Reflection and transmission of a shock wave.

where it has been taken into account that the form of the solution for the stresses, see (10.64) and (10.68), involves factors ρc , and signs of the terms different from those in the expressions for the velocity. In the case considered here, where the first part of the pile is 9 times stiffer than the rest of the pile, it appears that the reflected wave leads to stresses of the opposite sign in the first part. Thus a compression wave in the pile is reflected in the first part by tension.

It may be interesting to note the two extreme cases of reflection. When the second part of the pile is so soft that it can be entirely disregarded (or, when the pile consists only of the first part, which is free to move at its end), the reflection coefficient for the velocity is $R_v = 1$, and for the stress it is $R_\sigma = -1$. This means that in this case a compression wave is reflected as a tension wave of equal magnitude. The velocity in the reflected wave is in the same direction as in the incident wave.

If the second part of the pile is infinitely stiff (or, if the pile meets a rigid foundation after the first part) the reflection coefficient for the velocity is $R_v = -1$, and for the stresses it is $R_\sigma = 1$. Thus, in this case a compression wave is reflected as a compressive wave of equal magnitude. These results are of great importance in pile driving. When a pile hits a very soft layer, a tension wave may be reflected from the

end of the pile, and a concrete pile may not be able to withstand these tensile stresses. Thus, the energy supplied to the pile must be reduced in this case, for instance by reducing the height of fall of the hammer. When the pile hits a very stiff layer the energy of the driving equipment may be increased without the risk of generating tensile stresses in the pile, and this may help to drive the pile through this stiff layer. Of course, great care must be taken when the pile tip suddenly passes from the very stiff layer into a soft layer. Experienced pile driving operators use these basic principles intuitively.

It may be noted that tensile stresses may also be generated in a pile when an upward traveling (reflected) wave reaches the top of the pile, which by that time may be free of stress. This phenomenon has caused severe damage to concrete piles, in which cracks developed near the top of the pile, because concrete cannot withstand large tensile stresses. In order to prevent this problem, driving equipment has been developed that continues to apply a compressive force at the top of the pile for a relatively long time. Also, the use of prestressed concrete results in a considerable tensile strength of the material.

The problem considered in this section can also be analyzed graphically, by using the method of characteristics, see figure 10.9. The data given above imply that the wave velocity in the second part of the pile is 3 times smaller than in the first part, and that the impedance in the second part is also 3 times smaller than in the first part. This means that in the lower part of the pile the slope of the characteristics is 3 times smaller than the slope in the upper part. In the figure these slopes have been taken as 1:3 and 1:1, respectively. Starting from the knowledge that the pile is initially at rest (1), and that at the top of the pile a compression wave of short duration is generated (2), the points in the v, σ -diagram, and the regions in the z, t -diagram can be constructed, taking into account that at the interface both v and σ must be continuous.

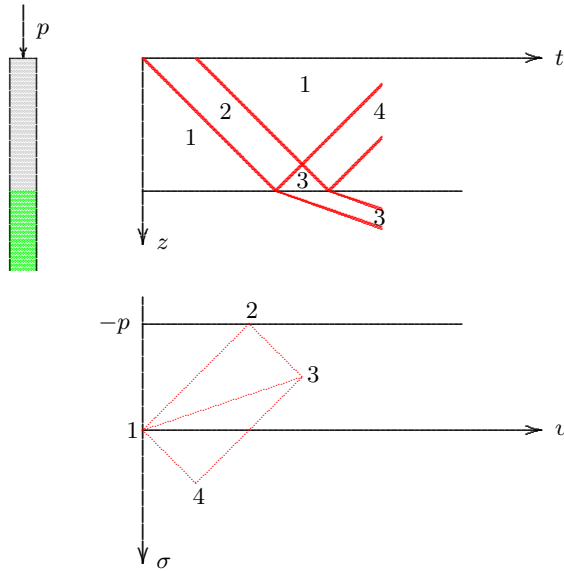

Figure 10.9: Graphical solution using characteristics.

10.6 The influence of friction

In soil mechanics piles in the ground usually experience friction along the pile shaft, and it may be illuminating to investigate the effect of this friction on the mechanical behaviour of the pile. For this purpose consider a pile of constant cross sectional area A and modulus of elasticity E , standing on a rigid base, and supported on its shaft by shear stresses that are generated by an eventual movement of the pile, see figure 10.10.

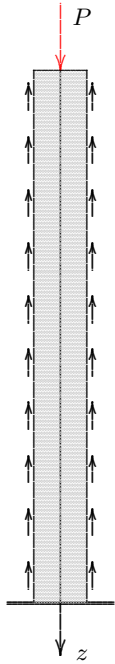

Figure 10.10: Pile in soil, with friction.

The differential equation is

$$EA \frac{\partial^2 w}{\partial z^2} - C\tau = \rho A \frac{\partial^2 w}{\partial t^2}, \quad (10.83)$$

where C is the circumference of the pile shaft, and τ is the shear stress. It is assumed, as a first approximation, that the shear stress along the pile shaft is linearly proportional to the vertical displacement of the pile,

$$\tau = kw, \quad (10.84)$$

where the constant k has the character of a subgrade modulus. The differential equation (10.83) can now be written as

$$\frac{\partial^2 w}{\partial z^2} - \frac{w}{H^2} = \frac{1}{c^2} \frac{\partial^2 w}{\partial t^2}, \quad (10.85)$$

where H is a length parameter characterizing the ratio of the axial pile stiffness to the friction constant,

$$H^2 = \frac{EA}{kC}, \quad (10.86)$$

and c is the usual wave velocity, defined by

$$c^2 = E/\rho. \quad (10.87)$$

The boundary conditions are supposed to be

$$z = 0 : N = EA \frac{\partial w}{\partial z} = -P \sin(\omega t). \quad (10.88)$$

$$z = L : w = 0, \quad (10.89)$$

The first boundary condition expresses that at the top of the pile it is loaded by a periodic force, of amplitude P and circular frequency ω . The second boundary condition expresses that at the bottom of the pile no displacement is possible, indicating that the pile is resting upon solid rock.

The problem defined by the differential equation (10.85) and the boundary conditions (10.88) and (10.89) can easily be solved by the method of separation of variables. In this method it is assumed that the solution can be written as the product of a function of z and a factor $\sin(\omega t)$. It turns out that all the conditions are met by the solution

$$w = \frac{PH}{EA\alpha} \frac{\sinh[\alpha(L-z)/H]}{\cosh(\alpha L/H)} \sin(\omega t), \quad (10.90)$$

where α is given by

$$\alpha = \sqrt{1 - \omega^2 H^2 / c^2}. \quad (10.91)$$

The displacement at the top of the pile, w_t , is of particular interest. If this is written as

$$w_t = \frac{P}{K} \sin(\omega t), \quad (10.92)$$

the spring constant K appears to be

$$K = \frac{EA}{L} \frac{\alpha L/H}{\tanh(\alpha L/H)}. \quad (10.93)$$

The first term in the right hand side is the spring constant in the absence of friction, when the elasticity is derived from the deformation of the pile only.

The behaviour of the second term in eq. (10.93) depends upon the frequency ω through the value of the parameter α , see eq. (10.91). It should be noted that for values of $\omega H/c > 1$ the parameter α becomes imaginary, say $\alpha = i\beta$, where now

$$\beta = \sqrt{\omega^2 H^2 / c^2 - 1}. \quad (10.94)$$

The spring constant can then be written more conveniently as

$$\omega H/c > 1 : K = \frac{EA}{L} \frac{\beta L/H}{\tan(\beta L/H)}. \quad (10.95)$$

This formula implies that for certain values of $\omega H/c$ the spring constant will be zero, indicating resonance. These values correspond to the eigen values of the system. For certain other values the spring constant is infinitely large. For these values of the frequency the system appears to be very stiff. In such a case part of the pile is in compression and another part is in tension, such that the total strains from bottom to top just cancel.

The value of the spring constant is shown, as a function of the frequency, in figure 10.11, for $H/L = 1$.

It is interesting to consider the probable order of magnitude of the parameters in engineering practice. For this purpose the value of the subgrade modulus k must first be evaluated. This parameter can be estimated to be related to the soil stiffness by a formula of the type

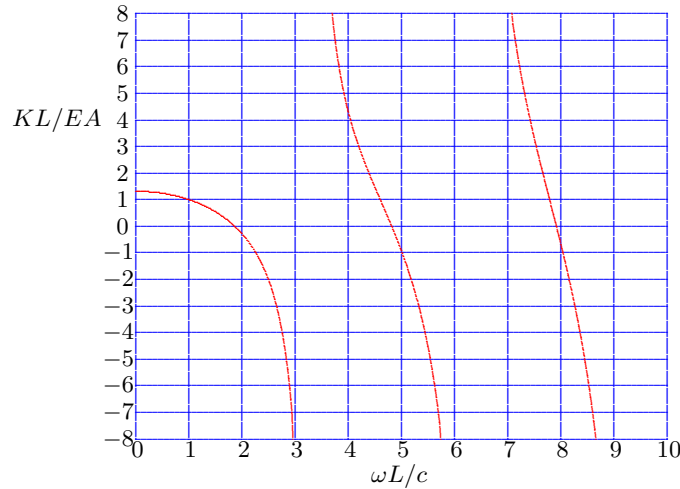

Figure 10.11: Spring constant ($H/L = 1$).

the order of magnitude of the parameter $\omega H/c$ is about 0.01. In such cases the value of α will be very close to 1, see eq. (10.91). This indicates that the response of the pile is practically static.

If the loading is due to the passage of a heavy train, at a velocity of 100 km/h, and with a distance of the wheels of 5 m, the period of the loading is about 1/6 s, and thus the frequency is about 30 s⁻¹. In such cases the parameter $\omega H/c$ may not be so small, indicating that dynamic effects may indeed be relevant.

Infinitely long pile

A case of theoretical interest is that of an infinitely long pile, $L \rightarrow \infty$. If the frequency is low this limiting case can immediately be obtained from the general solution (10.93), because then the function $\tanh(\alpha L/H)$ can be approximated by its asymptotic value 1. The result is

$$L \rightarrow \infty, \omega H/c < 1 : K = \frac{EA\alpha}{H}. \quad (10.97)$$

This solution degenerates when the dimensionless frequency $\omega H/c = 1$, because then $\alpha = 0$, see (10.91). Such a zero spring constant indicates resonance of the system.

For frequencies larger than this resonance frequency the solution (10.95) can not be used, because the function $\tan(\beta L/H)$ continues to fluctuate when its argument tends towards infinity. Therefore the problem must be studied again from the beginning, but now for an infinitely

$k = E_s/D$, where E_s is the modulus of elasticity of the soil (assuming that the deformations are small enough to justify the definition of such a quantity), and D is the width of the pile. For a circular concrete pile of diameter D the value of the characteristic length H now is, with (10.86),

$$H^2 = \frac{EA}{kC} = \frac{E_c D^2}{2E_s}. \quad (10.96)$$

Under normal conditions, with a pile being used in soft soil, the ratio of the elastic moduli of concrete and soil is about 1000, and most piles have diameters of about 0.40 m. This means that $H \approx 10$ m. Furthermore the order of magnitude of the wave propagation velocity c in concrete is about 3000 m/s. This means that the parameter $\omega H/c$ will usually be small compared to 1, except for phenomena of very high frequency, such as may occur during pile driving. In many civil engineering problems, where the fluctuations originate from wind or wave loading, the frequency is usually about 1 s⁻¹ or smaller, so that

long pile. The general solution of the differential equation now appears to be

$$w = [C_1 \sin(\beta z/H) + C_2 \cos(\beta z/H)] \sin(\omega t) + [C_3 \sin(\beta z/H) + C_4 \cos(\beta z/H)] \cos(\omega t), \quad (10.98)$$

and there is no combination of the constants C_1 , C_2 , C_3 and C_4 for which this solution tends towards zero as $z \rightarrow \infty$. This dilemma can be solved by using the *radiation condition*, which states that it is not to be expected that waves travel from infinity towards the top of the pile. Therefore the solution (10.98) is first rewritten as

$$w = D_1 \sin(\omega t - \beta z/H) + D_2 \cos(\omega t - \beta z/H) + D_3 \sin(\omega t + \beta z/H) + D_4 \cos(\omega t + \beta z/H). \quad (10.99)$$

Written in this form it can be seen that the first two solutions represent waves traveling from the top of the pile towards infinity, whereas the second two solutions represent waves traveling from infinity up to the top of the pile. If the last two are excluded, by assuming that there is no agent at infinity which generates such incoming waves, it follows that $D_3 = D_4 = 0$. The remaining two conditions can be determined from the boundary condition at the top of the pile, eq. (10.88). The final result is

$$w = \frac{PH}{EA\beta} \sin(\omega t - \beta z/H). \quad (10.100)$$

It should be noted that this solution applies only if the frequency ω is sufficiently large, so that $\omega H/c > 1$. Or, in other words, the solution applies only if the frequency is larger than the eigen frequency of the system.

10.7 Numerical solution

In order to construct a numerical model for the solution of wave propagation problems the basic equations are written in a numerical form.

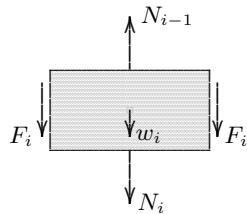

Figure 10.12: Element of pile.

For this purpose the pile is subdivided into n elements, all of the same length Δz . The displacement w_i and the velocity v_i of an element are defined in the centroid of element i , and the normal forces N_i is defined at the boundary between elements i and $i + 1$, see figure 10.12. The friction force acting on element i is denoted by F_i . This particular choice for the definition of the various quantities either at the centroid of the elements or at their boundaries, has a physical background. The velocity derives its meaning from a certain mass, whereas the normal force is an interaction between the material on both sides of a section. It is interesting to note, however, that this way of modeling, sometimes denoted as *leap frog* modeling, also has distinct mathematical advantages, with respect to accuracy and stability.

The equation of motion of an element is

$$N_i - N_{i-1} + F_i = \rho A \Delta z \frac{v_i(t + \Delta t) - v_i(t)}{\Delta t}, (i = 1, \dots, n). \quad (10.101)$$

It should be noted that there are $n + 1$ normal forces, from N_0 to N_n . The force N_0 can be considered to be the force at the top of the pile, and N_n is the force at the bottom end of the pile.

The displacement w_i is related to the velocity v_i by the equation

$$v_i = \frac{w_i(t + \Delta t) - w_i(t)}{\Delta t}, (i = 1, \dots, n). \quad (10.102)$$

The deformation is related to the normal force by Hooke's law, which can be formulated as

$$N_i = EA \frac{w_{i+1} - w_i}{\Delta z}, (i = 1, \dots, n - 1). \quad (10.103)$$

Here EA is the product of the modulus of elasticity E and the area A of the cross section.

The values of the normal force at the top and at the bottom of the pile, N_0 and N_n are supposed to be given by the boundary conditions.

Example

A simple example may serve to illustrate the numerical algorithm. Suppose that the pile is initially at rest, and let a constant force P be applied at the top of the pile, with the bottom end being free. In this case the boundary conditions are

$$N_0 = -P, \quad (10.104)$$

and

$$N_n = 0. \quad (10.105)$$

The friction forces are supposed to be zero.

At time $t = 0$ all quantities are zero, except N_0 . A new set of velocities can now be calculated from equations (10.101). Actually, this will make only one velocity non-zero, namely v_1 , which will then be

$$v_1 = \frac{P \Delta t}{\rho A \Delta z}. \quad (10.106)$$

Next, a new set of values for the displacements can be calculated from equations (10.102). Again, in the first time step, only one value will be non-zero, namely

$$w_1 = v_1 \Delta t = \frac{P(\Delta t)^2}{\rho A \Delta z}. \quad (10.107)$$

Finally, a new set of values for the normal force can be calculated from equations (10.103). This will result in N_1 getting a value, namely

$$N_1 = -EA \frac{w_1}{\Delta z} = -P \frac{c^2 (\Delta t)^2}{(\Delta z)^2}. \quad (10.108)$$

This process can now be repeated, using the equations in the same order.

An important part of the numerical process is the value of the time step used. The description of the process given above indicates that in each time step the non-zero values of the displacements, velocities and normal forces increase by 1 in downward direction. This suggests that in each time step a wave travels into the pile over a distance Δz . In the previous section, when considering the analytical solution of a similar problem (actually, the same problem), it was found that waves travel in the pile at a velocity

$$c = \sqrt{E/\rho}. \quad (10.109)$$

Combining these findings suggests that the ratio of spatial step and time step should be

$$\Delta z = c \Delta t. \quad (10.110)$$

It may be noted that this means that equation (10.106) reduces to

$$v_1 = \frac{P}{\rho A c}. \quad (10.111)$$

The expression in the denominator is precisely what was defined as the impedance in the previous section, see (10.58), and the value P/J corresponds exactly to what was found in the analytical solution. Equation (10.107) now gives

$$w_1 = \frac{P \Delta t}{\rho A c}, \quad (10.112)$$

and the value of N_1 after one time step is found to be, from (10.108),

$$N_1 = -P. \quad (10.113)$$

Again this corresponds exactly with the analytical solution. If the time step is chosen different from the critical time step the numerical solution will show considerable deviations from the correct analytical solution.

All this confirms the propriety of the choice (10.110) for the relation between time step and spatial step. In a particular problem the spatial step is usually chosen first, by subdividing the pile length into a certain number of elements. Then the time step may be determined from (10.110).

It should be noted that the choice of the time step is related to the algorithm proposed here. When using a different algorithm it may be more appropriate to use a different (usually smaller) time step than the critical time step used here (Bowles, 1974).

A program in Turbo Pascal that performs the calculations described above is reproduced below. The program uses interactive input, in which the user has to enter all the data before the calculations are started. The program will show the forces in the elements of the pile on the screen, in tabular form. Other forms of output, such as the presentation of the displacements and the velocities, or graphical output, may be added by the user.

```

program impact;
uses crt;
const
  maxel=20;
var
  length,elasto,rho,c,dz,dt,time:real;
  step,nel,steps,i:integer;
  v,w,s:array[0..maxel] of real;
procedure title;
begin
  clrscr;gotoxy(36,1);textbackground(7);textcolor(0);write(' IMPACT ');
  textbackground(0);textcolor(7);writeln;writeln;
end;
procedure next;
var
  a:char;
begin
  gotoxy(25,25);textbackground(7);textcolor(0);
  write(' Touch any key to continue ');write(chr(8));
  a:=readkey;textbackground(0);textcolor(7)
end;
procedure input;
begin
  title;
  writeln('This is a program for the analysis of axial waves in a pile. ');
  writeln;
  writeln('At t = 0 the pile is hit at its top by a force, generating a');
  writeln('unit stress in the pile. ');writeln;
  write('Length of the pile (m) ..... ');readln(length);writeln;

```

```

write('Modulus of elasticity (kN/m2) ... ');readln(elasto);writeln;
write('Mass density (kg/m3) ..... ');readln(rho);writeln;
write('Number of elements (max. 20) ... ');readln(nel);writeln;
write('Number of time steps ..... ');readln(steps);writeln;
if nel<10 then nel:=10;if nel>maxel then nel:=maxel;
dz:=length/nel;c:=sqrt(elasto/rho);dt:=dz/c;time:=0.0;
for i:=0 to nel do
  begin
    s[i]:=0.0;v[i]:=0.0;w[i]:=0.0;
  end;
s[0]:=1.000;
end;
procedure solve;
begin
  for i:=1 to nel do v[i]:=v[i]+(s[i]-s[i-1])/(rho*c);
  for i:=1 to nel do w[i]:=w[i]+v[i]*dt;
  for i:=1 to nel-1 do s[i]:=elasto*(w[i+1]-w[i])/dz;time:=time+dt;
  clrscr;writeln('Time : ',time:12:6);writeln;
  for i:=0 to nel do writeln(s[i]:12:6);next;
end;
begin
  input;
  for step:=1 to steps do solve;
  title;
end.

```

Program IMPACT.

When running the program it will be seen that indeed a wave travels through the pile, in agreement with the analytical solution of the previous section.

10.8 A simple model for a pile with friction

When there is friction along the shaft of the pile, this can be introduced through the variables F_i . It is then of great importance to know the relation between the friction and variables such as the displacement and the velocity. A simple model is to assume that the friction is proportional to the velocity, always acting in the direction opposite to the velocity. The program FRICTION, presented below will perform these calculations.

```

program friction;
uses crt;

```

```

const
  mm=1000;
var
  length,area,circ,elasto,rho,force,temp,fric,c,dz,dt,time,ff,aa,bb:real;
  step,m,steps,i:integer;
  v,w,s:array[0..mm] of real;
procedure title;
begin
  clrscr;gotoxy(36,1);textbackground(7);textcolor(0);write(' FRICTION ');
  textbackground(0);textcolor(7);writeln;writeln;
end;
procedure next;
var
  a:char;
begin
  gotoxy(25,25);textbackground(7);textcolor(0);
  write(' Touch any key to continue ');write(chr(8));
  a:=readkey;textbackground(0);textcolor(7)
end;
procedure input;
begin
  title;
  writeln('This is a program for the analysis of axial waves in a pile. ');
  writeln;
  writeln('At the top of the pile a force is applied, for a given time. ');
  writeln;
  write('Length of the pile (m) ..... ');readln(length);
  write('Area of cross section (m2) ..... ');readln(area);
  write('Circumference (m) ..... ');readln(circ);
  write('Modulus of elasticity (kN/m2) ... ');readln(elasto);
  write('Mass density (kg/m3) ..... ');readln(rho);
  write('Number of elements (max. 20) .... ');readln(m);
  write('Force at the top (kN) ..... ');readln(force);
  write('Duration of force (s) ..... ');readln(temp);
  write('Friction (kN/m2 per m/s) ..... ');readln(fric);
  write('Number of time steps ..... ');readln(steps);
  if m<10 then m:=10;if m>mm then m:=mm;
  dz:=length/m;c:=sqrt(elasto/rho);dt:=dz/c;time:=0.0;
  for i:=0 to m do
  begin
    s[i]:=0.0;v[i]:=0.0;w[i]:=0.0;
  end;
  fric:=fric*dz*circ;

```

```

end;
procedure solve;
begin
  s[0]:=0.0;if time<temp then s[0]:=-force;
  for i:=1 to m do v[i]:=v[i]+(s[i]-s[i-1]-fric*v[i])/(rho*area*c);
  for i:=1 to m do w[i]:=w[i]+v[i]*dt;
  for i:=1 to m-1 do s[i]:=elasto*area*(w[i+1]-w[i])/dz;
  time:=time+dt;clrscr;writeln('Time : ',time:12:6);
  writeln('
          N          v          w');
  writeln(s[0]:18:6);
  for i:=1 to m do writeln(s[i]:18:6,v[i]:18:6,w[i]:18:6);next;
end;
begin
  input;
  for step:=1 to steps do solve;
end.

```

Program FRICTION.

The variable "fric" in this program is the shear stress generated along the shaft of the pile in case of a unit velocity (1 m/s). In professional programs a more sophisticated formula for the friction may be used, in which the friction not only depends upon the velocity but also on the displacement, in a non-linear way. Also a model for the resistance at the point of the pile may be introduced, and the possibility of a layered soil.

Problems

- 10.1** A free pile is hit by a normal force of short duration. Analyze the motion of the pile by the method of characteristics, using a diagram as in figure 10.5.
- 10.2** Extend the diagram shown in figure 10.9 towards the right, so that the reflected wave hits the top of the pile, and is again reflected there.
- 10.3** As a first order approximation of eq. (10.46) the response of a pile may be considered to be equivalent to a spring, see eq. (10.48). Show, by using an approximation of the function $\tan(\omega h/c)$ by its first two terms, that a second order approximation is by a spring and a mass. What is the equivalent mass?
- 10.4** Modify the program IMPACT such that it will print the velocity of the pile, and verify that the analytical solution is correctly reproduced. Also verify that by using a time step different from the one used in the program, the approximation is not so good.

10.5 Run the program FRICTION using the following parameters :

```
length=20,  
area=1,  
circ=1,  
elasto=20000000,  
rho=2000,  
nel=20,  
force=100,  
temp=1,  
fric=1000,  
steps=5000.
```

Show that the pile comes to rest after such a great number of time steps.

10.6 Verify some of the characteristic data shown in figure 10.11. For instance, check the values for $\omega L/c = 0$ and $\omega L/c = 1$, and check the zeroes of the spring constant.

Chapter 11

GRAVITY FOUNDATIONS

11.1 Introduction

For the foundation of large offshore platforms in deep water a suitable type of foundation is a *gravity foundation*. This is a large and heavy concrete structure, see figure 11.1, with a number of towers on which the actual platform is built. The basic structural principle of this type of foundation is that the large weight of the structure results in large vertical stresses below the foundation, which enable to withstand the large

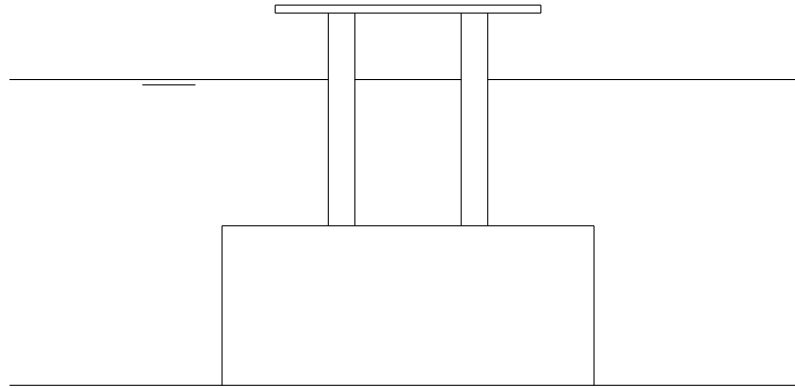

Figure 11.1: Gravity structure.

horizontal shear stresses that are generated by the wave loading during storms. The structure may be built onshore, for instance in a dockyard, and then floated to its offshore location, where the topside facilities may be completed.

There are a number of soil mechanics problems associated with these structures: the stability of the structure during wave loading, settlements during and after placement, and settlement due to oil or gas production. These problems are addressed in this chapter.

11.2 Bearing capacity

The over-all stability of a gravity structure is usually analyzed by considering the bearing capacity of the soil. This is a well known problem of

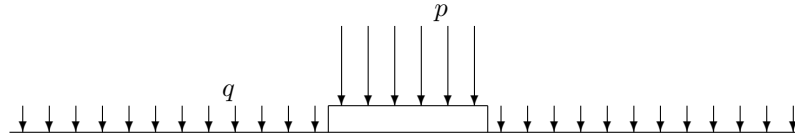

Figure 11.2: Bearing capacity.

classical soil mechanics, based upon the theory of plasticity. The solution for the simplest case has been obtained by Prandtl. It was generalized later by Terzaghi and Brinch Hansen. For a homogeneous soil the maximum load that can be carried by a strip footing can be written as

$$p_c = N_q q + N_c c + \frac{1}{2} N_\gamma \gamma B, \quad (11.1)$$

where q is the soil pressure next to the foundation, c is the cohesion of the soil, γ is the volumetric weight of the soil, and B is the width of the foundation strip.

The coefficients N_q , N_c and N_γ in eq. (11.1) are functions of the friction angle ϕ . The coefficients N_q and N_c have been determined by Prandtl, from analytical solutions of the plasticity problem.

$$N_q = \frac{1 + \sin \phi}{1 - \sin \phi} \exp(\pi \tan \phi), \quad (11.2)$$

$$N_c = (N_q - 1) \cot \phi. \quad (11.3)$$

For the value of the coefficient N_γ various investigators have proposed expressions, based upon approximate calculations, for instance

$$N_\gamma = \frac{3}{2} (N_q - 1) \tan \phi. \quad (11.4)$$

A short table of values of the bearing capacity factors is given in table 11.1.

The formula (11.1) applies to a strip foundation carrying a vertical load. For a foundation of different shape, and for an inclined load, correction factors have been derived by Brinch Hansen. The generalized formula then is

$$p_c = i_q s_q N_q q + i_c s_c N_c c + \frac{1}{2} i_\gamma s_\gamma N_\gamma \gamma B, \quad (11.5)$$

ϕ	N_q	N_c	N_γ
0	1.000	5.142	0.000
5	1.568	6.489	0.075
10	2.471	8.345	0.389
15	3.941	10.977	1.182
20	6.399	14.835	2.948
25	10.662	20.721	6.758
30	18.401	30.140	15.070
35	33.296	46.124	33.921
40	64.195	75.313	79.541

Table 11.1: Bearing capacity factors.

where the coefficients i are inclination factors, indicating the effect of an inclined load, and the coefficients s are shape factors, indicating the effect of the shape of the foundation. The values of the correction factors cannot be determined in a rigorous way. Acceptable values are

$$i_c = 1 - \frac{t}{c + p \tan \phi}, \quad (11.6)$$

$$i_q = i_c^2, \quad (11.7)$$

$$i_\gamma = i_c^3, \quad (11.8)$$

$$s_c = 1 + 0.2 \frac{B}{L}, \quad (11.9)$$

$$s_q = 1 + \frac{B}{L} \sin \phi, \quad (11.10)$$

$$s_\gamma = 1 - 0.4 \frac{B}{L}, \quad (11.11)$$

where B is the width of the rectangular foundation plate, and L is its length, assuming that $L \geq B$.

For foundations on land the third term in eq. (11.1) is usually very small, because γB is usually small compared to the surcharge q . In the case of an offshore gravity foundation the width B is very large, however, and the surcharge q is practically zero. Thus the gravity term becomes very important. Unfortunately the theoretical basis of this term is not so very sound, compared to that of the other two terms. Therefore the determination of the bearing capacity must be viewed with caution.

It is illustrative to consider an example, for a square gravity foundation on sand. If there is no surcharge ($q = 0$), and the sand is cohesionless ($c = 0$), the formula for the bearing capacity reduces to

$$p_c = 0.3i_\gamma N_\gamma \gamma B, \quad (11.12)$$

with

$$i_\gamma = \left(1 - \frac{\tan \alpha}{\tan \phi}\right)^3, \quad (11.13)$$

The value of the shape factor has been taken as 0.6, in agreement with eq. (11.11). In eq. (11.13) α is the inclination of the load ($\tan \alpha = t/p$). It follows from eq. (11.12) that the influence of the inclination of the load is very large. If $\phi = 30^\circ$ and $\alpha = 10^\circ$ the value of the inclination factor is as small as $i_\gamma = 0.3351$, see also table 11.2. Because offshore structures may be subject to very large horizontal loads, this means that

α	i_γ
0°	1.0000
5°	0.6108
10°	0.3351
15°	0.1539
20°	0.0505
25°	0.0071
30°	0.0000

Table 11.2: Inclination factor.

it is very important to pay much attention to a careful analysis of this type of loading.

It must be noted that all the stresses in the formulas presented above are *effective stresses*. In the most simple case this can be taken into account by considering the volumetric weight γ as the weight of the soil *under water*. It may also happen, however, that excess pore pressures are generated below the foundation. It appears that this may have a large influence on the stability of the structure, because the inclination factor then becomes much smaller. This effect will be considered in the next section.

Another aspect that deserves attention is that the Brinch Hansen formula (11.5) applies only to a homogeneous soil. In many cases the sea bottom will consist of layers of variable properties. For such cases the simple analysis using the bearing capacity formulas is not applicable. A more refined analysis is then necessary, for instance using a numerical method. This also enables to taken into account the soil behaviour in a more realistic way.

11.3 Pore pressures

Under a gravity foundation pore pressures may be generated by the loads on the structure. These will be gradually dissipated, because an excess pore water pressure will lead to a flow of the groundwater to the draining boundaries. This process is called *consolidation*. The duration of the consolidation process can be estimated by the formula

$$t_c = 2 \frac{L^2}{c_v}, \quad (11.14)$$

where L is the (average) length of the drainage path, and c_v is the consolidation coefficient,

$$c_v = \frac{k}{m_v \gamma_w}. \quad (11.15)$$

Here k is the permeability coefficient of the soil, m_v its compressibility, and γ_w is the volumetric weight of the pore fluid (water). For sand typical values are

$$\begin{aligned} k &= 10^{-5} \text{ m/s} \dots 10^{-4} \text{ m/s}, \\ m_v &= 10^{-5} \text{ m}^2/\text{kN} \dots 10^{-4} \text{ m}^2/\text{kN}. \end{aligned}$$

Because $\gamma_w = 10 \text{ kN/m}^3$ the order of magnitude of the consolidation coefficient is, approximately,

$$c_v = 0.01 \text{ m}^2/\text{s} \dots 0.1 \text{ m}^2/\text{s}.$$

Assuming a drainage length $L = 50 \text{ m}$ one now obtains that the consolidation time is, approximately,

$$t_c = 50 \times 10^3 \text{ s} \dots 500 \times 10^3 \text{ s}.$$

This is about 1 to 10 days, which means that the pore pressures generated during installation of the platform will be dissipated in a few days. However, even in a relatively permeable material such as sand, the consolidation time may be long compared to the duration of a storm.

It should be noted that in a clay soil the consolidation time may be several orders of magnitude longer, because of the very low permeability. In such a soil the settlements of the platform after installation may be time dependent because of consolidation.

Pore pressure generation

In the theory of consolidation a prominent role is played by the storage equation. This equation expresses that a volume change of the soil can only occur if either the pore fluid is compressed, or if the pore fluid is expelled from the soil,

$$-\frac{\partial e}{\partial t} = n\beta \frac{\partial p}{\partial t} + \nabla \cdot \mathbf{q}, \quad (11.16)$$

where e is the volume strain of the soil, p is the excess pore pressure, and \mathbf{q} is the flow rate of the fluid. The first term in the right hand side is the compression of the fluid in the pores, where β is the compressibility of the fluid. The second term represents the loss of water in a unit volume due to the flow. It has been assumed, following standard soil mechanics practice, that the soil particles are incompressible. This is acceptable when considering soft and loose soils.

A volume change of the soil skeleton may be produced in various ways. The most elementary form is when the isotropic component of the effective stress is modified. This is the classical case of compression, which is governed by the bulk modulus K ,

$$e = e_1 = -\frac{\sigma'}{K} = -\frac{\sigma - p}{K}. \quad (11.17)$$

Here σ' is the isotropic effective stress, σ is the isotropic total stress, and p is the pore pressure. All these stresses should be interpreted as incremental to the initial state.

A second form of volume change is the one which may accompany shear deformations. This is an important feature of many soils. In its simplest form it means that a loose soil will show a tendency to reduce its volume (*contraction*), and that a dense soil will show a tendency to expand (*dilatancy*). In the case of offshore structures the main effect is that the shear deformations are cyclic, because of the cyclic nature of the wave loads. Soil testing has shown that the volume change due to shear practically disappears after a full cycle, but in many cases a small volume reduction remains. This effect can readily be imagined: during shear the soil particles move with respect to each other, and a particle that has found a convenient niche will not give that up when the load is reversed. Thus there may also be cyclic volume change. As a first approximation this cyclic volume change can be assumed to be proportional to the number of cycles, and proportional to the load. If the load is symbolically denoted as

$$\tau = \tau_o \sin\left(\frac{2\pi t}{T}\right), \quad (11.18)$$

where T is the period of the load, the permanent component of the volume change that can be expected is

$$e = e_2 = -\delta\tau_o \frac{t}{T}, \quad (11.19)$$

where δ is an as yet unknown parameter.

Substitution of the sum of (11.17) and (11.19) into (11.16) gives, assuming that the isotropic total stress is constant in time (this will be the case during a storm, at least on the average),

$$(1 + n\beta K) \frac{\partial p}{\partial t} + K \nabla \cdot \mathbf{q} = \frac{K\delta\tau_o}{T}. \quad (11.20)$$

Here the coefficient $n\beta K$, which is the relative compressibility of the pore fluid compared to the compressibility of the soil, may be very small when the soil is saturated with water.

In order to obtain some more insight into the parameter δ it is convenient to consider the experimental results obtained by Bjerrum (1973), and others. On the basis of undrained cyclic simple shear tests Bjerrum proposed a relation for the pore pressure generated in these tests due

to cyclic loading of the form

$$p = B\tau_o N = B\tau_o \frac{t}{T}, \quad (11.21)$$

where N is the number of cycles, which may be identified with the ratio t/T , used previously. The dimensionless parameter B indicates the sensitivity of the soil to pore pressure generation. Its value may be 10^{-5} up to 10^{-3} .

In undrained conditions the term due to the flow of the pore fluid in eq. (11.20) vanishes. This equation then reduces to

$$\frac{\partial p}{\partial t} = \frac{K\delta\tau_o}{(1+n\beta K)T}. \quad (11.22)$$

Comparison of eqs. (11.21) and (11.22) shows that they are equivalent if

$$\delta = \frac{(1+n\beta K)B}{K}. \quad (11.23)$$

In terms of Bjerrum's parameter B the basic differential equation (11.20) can be written as

$$\frac{\partial p}{\partial t} + \frac{K}{1+n\beta K} \nabla \cdot \mathbf{q} = \frac{B\tau_o}{T}. \quad (11.24)$$

In this way the effect of cyclic generation of pore pressures may be incorporated into a deformation model.

Estimation of pore pressures

In order to estimate the order of magnitude of the pore pressures the basic equation (11.24) may be averaged over the entire domain (Verruijt, 1980). If the average pore pressure \bar{p} is defined as

$$\bar{p} = \frac{1}{V} \int_V p dV, \quad (11.25)$$

the result is, using Gauss' divergence theorem,

$$\frac{d\bar{p}}{dt} + \frac{1}{V} \int_A q_n dS = \frac{B\bar{\tau}_o}{T}. \quad (11.26)$$

Along impermeable boundaries the flow rate q_n vanishes. Along the remaining drained part of the boundary A_d the flow rate may be estimated to be

$$q_n = -\frac{k}{\gamma} \frac{\partial p}{\partial n} = \frac{k}{\gamma} \frac{3\bar{p}}{L}, \quad (11.27)$$

where L is the drainage length, which may be estimated to be $L = V/A_d$. The factor 3 in eq. (11.27) has been obtained by assuming that the pore pressure varies parabolically from zero along the boundary to a value $\frac{3}{2}\bar{p}$ at a distance L . The average value then is \bar{p} and the slope at the boundary is $3\bar{p}/L$. Eq. (11.26) now becomes

$$\frac{d\bar{p}}{dt} + \frac{3c_v}{L^2}\bar{p} = \frac{B\bar{\tau}_o}{T}, \quad (11.28)$$

where c_v is the consolidation coefficient, in this case defined as

$$c_v = \frac{kK}{(1 + n\beta K)\gamma_w}. \quad (11.29)$$

The solution of the differential equation (11.28) is, assuming that the initial value of the pore pressure is zero,

$$\bar{p} = \frac{B\bar{\tau}_o t_c}{6T} [1 - \exp(-\frac{6t}{t_c})], \quad (11.30)$$

where t_c is the consolidation time, defined as

$$t_c = 2\frac{L^2}{c_v}. \quad (11.31)$$

The maximum pore pressure is

$$\bar{p}_{max} = \frac{B\bar{\tau}_o t_c}{6T}. \quad (11.32)$$

This maximum is reached when the time t approaches the consolidation time t_c . At that time the generation of pore pressures due to cyclic loading is balanced by the dissipation due to flow.

It can be seen from eq. (11.32) that the maximum pore pressure can be reduced by reducing the parameter B , which may be accomplished by artificial densification of the soil. In the case of the storm surge barrier in the Eastern Scheldt this has indeed been done. Another very effective way to reduce the pore pressures is to reduce the consolidation time. This may be accomplished by improving the drainage possibilities, for instance by the installation of gravel packs. If the drainage length can be reduced by a factor 2 the consolidation time is shortened by a factor 4, and thus the maximum pore pressure is also reduced by a factor 4.

Nature itself also provides a mechanism for improvement. A not too large storm may result in some pore pressure generation, and subsequent consolidation. By this effect the density of the soil increases, and thus the value of the parameter B is reduced. Of course this pre-shearing effect works only if the major design storm is not the first one to attack the platform, and it may therefore be considered too much of a risk to count upon it.

It is to be noted that all the calculations in this chapter are of an approximative character, and merely give some insight into the phenomena involved. They should not be considered as design rules. For the complete design of a gravity foundation it is necessary to perform a detailed analysis of these phenomena. This should include a thorough exploration of the local soil profile, a determination of the soil parameters by in situ or laboratory testing, and detailed calculations of the bearing capacity and the pore pressures.

11.4 Settlements

During placement of a gravity platform a large settlement of the sea bottom, and thus of the foundation, can be expected, because of the very high stresses. After completion of the platform additional settlements may occur due to consolidation, creep, and extraction of gas and oil from the reservoir.

11.4.1 Consolidation

Consolidation settlements must be taken into account only in case of clay deposits. They can be calculated in the usual way, by determining the consolidation properties of the clay layers, and then using the consolidation theory to predict the behaviour as a function of time. In most cases it is not really necessary to use three-dimensional consolidation theory. A one-dimensional approach is usually sufficiently accurate.

11.4.2 Creep

Creep settlements of the layers near the sea bottom surface can be taken into account by assuming the usual logarithmic time dependence of these settlements,

$$\varepsilon = \varepsilon_p + \varepsilon_s \log(t/t_o). \quad (11.33)$$

The parameters ε_p and ε_s must be determined from laboratory tests. They depend in a non-linear way upon the stresses. Therefore the most effective procedure is to determine their value by simulating the in situ stress path in the laboratory. In general this must be done for the soil at various depths beneath the structure, taking into account the variation of the stresses with depth, and the variability of the soil. In order to determine the actual settlements the strains in each layer must be multiplied by the layer thickness, and then summed over all layers.

11.4.3 Deformations of the reservoir

The purpose of most offshore operations is to extract gas or oil from deep reservoirs. In this process gas or oil is produced out of the pores of a porous rock, usually by reducing the pressure in these pores. This leads to an increase of the effective stresses in the rock, and thus to deformations. These deformations are usually predicted using Biot's theory of consolidation, using the appropriate values for the compressibility of the reservoir. One of the most important parts of such calculations is the prediction of surface subsidence. In many cases this surface subsidence is of great importance.

REFERENCES

- M. Abramowitz and I.A. Stegun, *Handbook of Mathematical Functions*, National Bureau of Standards, Washington, 1964.
- American Petroleum Institute, *API Recommended Practice for Planning, Design and Constructing Fixed Offshore Platforms*, API, Dallas, 1981.
- H. Bateman, *Tables of Integral Transforms*, 2 vols, McGraw-Hill, New York, 1954.
- M.A. Biot, General theory of three-dimensional consolidation, *J. Appl. Phys.*, **12**, 155-164, 1941.
- M.A. Biot, Theory of propagation of elastic waves in a fluid-saturated porous solid, *J. Acoust. Soc. Amer.*, **28**, 168-191, 1956.
- L. Bjerrum, Geotechnical problems involved in foundations of structures in the North Sea, *Geotechnique*, **23**, 319-359, 1973.
- H. Blum, *Einspannungsverhältnisse bei Bohlwerken*, Wilhelm Ernst & Sohn, Berlin, 1931.
- J.E. Bowles, *Analytical and Computer Methods in Foundation Engineering*, McGraw-Hill, New York, 1974.
- J. Brinch Hansen, A revised and extended formula for bearing capacity, *Bulletin of the Danish Geotechnical Institute*, **28**, 5-11, 1970.
- R.V. Churchill, *Operational Mathematics*, 2nd ed., McGraw-Hill, New York, 1958.
- J.G.M. van der Grinten, *An Experimental Study of Shock-induced Wave Propagation in Dry, Water-saturated and Partially Saturated Porous Media*, Ph.D. Thesis, Eindhoven, 1987.
- W. Gröbner and N. Hofreiter, *Integraltafel*, Springer, Wien, 1961.
- M. Hetenyi, *Beams on Elastic Foundation*, University of Michigan Press, Ann Arbor, 1946.
- G. de Josselin de Jong, Wat gebeurt er in de grond tijdens het heien?, *De Ingenieur*, **68**, B77-B88, 1956.
- G. de Josselin de Jong, Consolidatie in drie dimensies, *LGM-Mededelingen*, **7**, 25-73, 1963.
- A.P. Kooijman, *A Numerical Model for Laterally Loaded Piles and Pile Groups*, Ph.D. Thesis, Delft, 1989.
- T.W. Lambe and R.V. Whitman, *Soil Mechanics*, Wiley, New York, 1969.
- E.C. Leong and M.F. Randolph, Finite element analyses of soil plug response, *Int. J. Numer. and Anal. Methods Geomech.*, **15**, 121-141, 1991.
- O.S. Madsen, Wave-induced pore pressures and effective stresses in a porous bed, *Geotechnique*, **28**, 377-393, 1978.
- K.L. Meijer and A.G. van Os, Pore pressures near moving underwater slope, *Journal of the Geotechnical Engineering Division, ASCE*, **102**, no. GT4, 361-372, 1976.
- A.G. van Os, Snelle deformatie van korrelvormig materiaal onder water, *Polytechnisch Tijdschrift*, **32**, 461-467, 1977.
- A.G. van Os and W. van Leussen, Basic research on cutting forces in saturated sand, *Journal of Geotechnical Engineering*, **113**, 1501-1516, 1987.

- H.G. Poulos, *Marine Geotechnics*, Unwin Hyman, London, 1988.
- M.F. Randolph, The axial capacity of deep foundations in calcareous soil, *Proc. Int. Conf. Calcareous Sediments*, **2**, 837-857, ISSMFE, Perth, Western Australia, 1988.
- R.L. Schiffman, A bibliography of consolidation, *Fundamentals of Transport Phenomena in Porous Media* (J. Bear and M.Y. Corapcioglu, editors), Martinus Nijhoff, Dordrecht, 617-669, 1984.
- E.A.L. Smith, Pile driving analysis by the wave equation, *Trans. ASCE*, **127**, 1145-1193, 1962.
- S.E.J. Spierenburg, *Seabed Response to Water Waves*, Ph.D. Thesis, Delft, 1987.
- S.P. Timoshenko and J.N. Goodier, *Theory of Elasticity*, 2nd ed., McGraw-Hill, New York, 1951.
- A. Verruijt, A simple formula for the estimation of pore pressures and their dissipation, *Applied Ocean Research*, **2**, 57-62, 1980.
- A. Verruijt, Approximations of cyclic pore pressures caused by sea waves in a poro-elastic half-plane, *Soil Mechanics – Transient and Cyclic Loads* (G.N. Pande and O.C. Zienkiewicz, editors), Wiley, London, 37-51, 1982.
- A. Verruijt, Numerieke berekening van verend ondersteunde liggers, *Cement*, **35**, 659-662, 1983.
- A. Verruijt, The theory of consolidation, *Fundamentals of Transport Phenomena in Porous Media*, (J. Bear and Y.M. Corapcioglu, editors), Martinus Nijhoff, Dordrecht, 330-350, 1984.
- A. Verruijt, The influence of soil properties on the behaviour of offshore structures, *Behaviour of Offshore Structures* (J.A. Battjes, editor), Elsevier, Amsterdam, 7-19, 1985.
- A. Verruijt and A.P. Kooijman, Laterally loaded piles in a layered elastic medium, *Géotechnique*, **39**, 39-46, 1989.
- A. Verruijt, V.M.J.P. de Bruijn and B. Muriladhar, Liquefaction around buried pipe lines, *Proceedings BOSS'97 conference* (J.H. Vugts, editor), **1**, 99-107, 1997.
- C.R. Wylie, *Advanced Engineering Mathematics*, 2nd ed., McGraw-Hill, New York, 1960.
- T. Yamamoto, H.L. Koning, J.B. Sellmeijer and E. van Hijum, On the response of a poro-elastic bed to water waves, *J. Fluid Mech.*, **87**, 193-206, 1978.

Index

- active soil pressure, 118
- Airy functions, 79, 97
- ALP (Program), 96
- axially loaded piles, 68

- beam theory, 54
- bearing capacity, 8, 81, 84, 192
- bending moment, 55
- Bernoulli's assumption, 116
- Biot's theory, 10, 44, 199
- Bjerrum's relation, 196
- Blum's approximation, 119
- Boussinesq, 5
- Brinch Hansen's formula, 9, 82, 192
- bulk modulus, 22

- cavitation, 49
- characteristic frequency, 170
- characteristics, 173
- cohesion, 119
- cohesive material, 71
- compatibility, 22
- compressibility, 7
- compression modulus, 22
- compression waves, 164
- cone penetration, 83

- cone penetration test, 8
- consolidation, 10, 199
- consolidation coefficient, 16, 32
- contraction, 196
- CPT, 8, 9, 83
- creep, 199
- critical time step, 186
- cutting forces, 44
- cyclic loading, 31, 136, 196

- damping, 135, 136, 143
- Darcy's law, 12
- degree of consolidation, 20
- dilatancy, 46, 196
- drained deformations, 23
- dynamic effects, 85
- dynamic pile loading test, 83

- effective stress, 14, 22
- eigen frequency, 170, 172
- eigen functions, 170
- elastic foundation, 55
- elastic modulus, 5
- elastic plug model, 99
- elasto-plastic response, 89, 118
- elasto-plasticity, 163

- finite pile, 166, 168
- fluid compressibility, 11, 32, 45
- friction, 81, 83, 179, 187
- FRICITION (Program), 189
- friction angle, 119
- frictional material, 77

- gravity foundations, 191

- Hooke's law, 22
- hydraulic conductivity, 13

- IMPACT (Program), 187
- impedance, 174, 185
- inclination factors, 193
- incompressible fluid, 36
- infinite pile, 165

- Lamé constants, 22
- Laplace transform, 165
- lateral earth pressure, 78
- laterally loaded piles, 115
- layered system, 145
- leap frog, 183
- linear material, 68, 115
- liquefaction, 41, 49
- LLP (Program), 135
- long waves, 36

- Mandel-Cryer effect, 29

- numerical plug model, 103

- offshore platforms, 191
- one-dimensional consolidation, 14

- passive soil pressure, 118
- permeability, 12
- PILAT (Program), 160
- pile driving, 164
- pile group, 163
- plastic material, 118
- plastic plug model, 102
- plate loading test, 8
- plug, 83, 99
- PLUG (Program), 113
- point resistance, 70, 81
- Poisson's ratio, 5
- pore pressures, 195, 197
- Prandtl, 82, 192
- preshearing, 42

- quake, 72, 106

- radial consolidation, 28
- radiation condition, 183
- references, 200
- reflection, 175
- reflection coefficient, 177
- reservoir deformations, 199
- resonance, 172

- separation of variables, 168
- settlement, 19
- settlements, 199
- shakedown, 137
- shape factors, 82, 193
- shear modulus, 22
- short waves, 36
- static pile loading test, 83
- stiffness, 5

storage equation, 12, 31, 44, 195
stroke, 119
subgrade modulus, 5, 56, 69, 116, 180

Terzaghi's formula, 7
Terzaghi's principle, 14, 22
Terzaghi's problem, 15
three-dimensional consolidation, 21
transmission, 175
transmission coefficient, 177

uncoupled consolidation, 26
undrained deformations, 24
undrained shear strength, 9

vertical slope, 52
viscosity, 12, 143
viscous damping, 141
volumetric weight, 13

water waves, 31
wave equation, 165
waves in piles, 164
WINKLER (Program), 66